

# MECHATRONIC SOLUTIONS

COMPACT - DYNAMIC - PRECISE

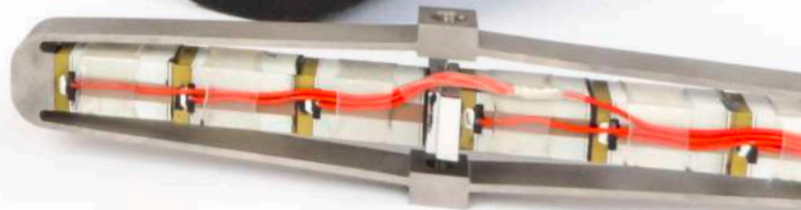

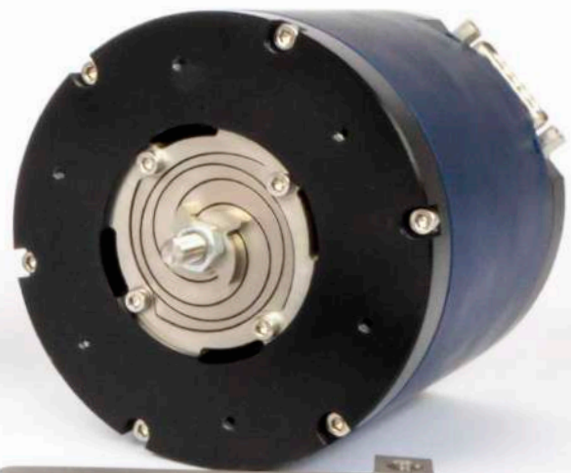

# TABLE OF CONTENTS

<b>1. CEDRAT TECHNOLOGIES ACTUATOR SOLUTIONS</b>	<b>7</b>
1.1. Introduction to piezo & magnetic actuators from Cedrat Technologies	7
1.2. Synthesis of Cedrat Technologies offer	8
1.3. Overview of Cedrat Technologies products & technologies	9
1.3.1. Parallel Pre-stressed Actuators PPA	10
1.3.2. Amplified Piezoelectric Actuators APA®	10
1.3.3. Stepping Piezo Actuators SPA	10
1.3.4. Moving Iron Controllable Actuator MICA™	10
1.3.5. Bistable Linear Moving Magnet BLMM	11
1.3.6. Moving Coil Actuators MCA	11
1.3.7. Sensors solutions	11
1.4. Cedrat Technologies services & facilities	12
1.4.1. Engineering services	12
1.4.2. Production & lab' capability	13
1.4.3. Technical assistance & training	13
<b>2. TUTORIAL</b>	<b>15</b>
2.1. Tutorial on piezoelectric actuators	15
2.1.1. Introduction to piezoelectric materials	15
2.1.2. Characteristics of piezoelectric materials	16
2.1.3. Advantages & limitations of piezo actuators	16
2.1.4. Parallel Pre-stressed Actuators PPA	17
2.1.5. Amplified Piezoelectric Actuators APA®	18
2.1.6. Stepping Piezo Actuators SPA	19
2.1.7. Static behaviour of piezoactive actuators	20
2.1.8. Dynamic behaviour of actuators (low level)	21
2.1.9. Limitations of piezoelectric actuators	22
2.1.10. Driving of piezoelectric actuators	25
2.2. Tutorial on magnetic actuators	27
2.2.1. Introduction to magnetic actuators	27
2.2.2. Moving Coil Actuators MCA	28
2.2.3. Conventional moving iron actuators - Electromagnets	29
2.2.4. Moving Iron Controllable Actuators MICA™	30
2.2.5. Bistable Linear Moving Magnets actuators BLMM	30
2.2.6. Limited Angle Torque actuators LAT	32
2.2.7. Choosing voltage or current electrical driving principles	33
2.2.8. Electrical impedance adjustment	34
2.2.9. Resonant flexure bearing actuators	34
2.2.10. Electromechanical limits of actuators	37
2.2.11. Active & reactive electrical power	38
2.2.12. Magnetic actuators heat dissipation	40
2.2.13. Analysis of magnetic actuators with losses	41

<b>3. MARKETS &amp; APPLICATIONS</b>	<b>43</b>
3.1. Market overview	43
3.2. Applications & functions classified by working conditions	45
3.2.1. Applications operated under static conditions	46
3.2.2. Applications operated under dynamic non-resonant conditions	48
3.2.3. Applications operated under dynamic resonant conditions	50
3.2.4. Applications operated under dynamic force conditions	51
3.2.5. Applications operated under impulse conditions	52
3.2.6. Applications operated under dynamic sensing conditions	53
3.3. Additional technological solutions	54
3.3.1. Hollow Parallel Prestressed Actuator HPPA	54
3.3.2. Extremely amplified actuators	54
3.3.3. Applications requiring a high stability in closed loop	55
3.3.4. Mechanically-damped Amplified Piezoelectric Actuators APA®	55
<b>4. PIEZO ACTUATORS</b>	<b>57</b>
4.1. Selection guide	57
4.1.1. Introduction	57
4.1.2. Mechanical interface options	58
4.1.3. Standard options	58
4.1.4. Specific versions	58
4.2. Amplified Piezoelectric Actuators APA®	60
4.2.1. APA® uXS & XXS series	60
4.2.2. APA® XS series	61
4.2.3. APA® S series	62
4.2.4. APA® SM series	63
4.2.5. APA® M series	64
4.2.6. Super APA® M series	65
4.2.7. APA® MML series	66
4.2.8. APA® ML series	67
4.2.9. APA® L series	68
4.2.10. APA® XL series	69
4.3. Multi-Layer Actuators MLA series	70
4.4. Parallel Pre-stressed Actuators PPA	71
4.4.1. PPA M series	71
4.4.2. PPA L series	72
4.4.3. PPA XL series	73
4.5. Customised piezo actuators	74
<b>5. PIEZO MECHANISMS</b>	<b>77</b>
5.1. Selection guide	77
5.2. X piezoelectric stages	78
5.3. XY piezoelectric stages	78
5.4. XYZ piezoelectric stages	78
5.5. Tilt Translator TT	79

5.6. Double Tilt Translator DTT	79
5.7. Fast Piezo Shutters FPS200M, FPS400M & FPS900M	80
5.8. Fast Amplified Piezo Shutter FAPS400M	80
5.9. Customised piezo mechanisms	81
<b>6. PIEZO MOTORS AND MOTORISED STAGES</b>	<b>83</b>
6.1. Linear Stepping Piezo Actuator LSPA	84
6.2. Linear Stepping Piezo Stage LSPS	85
6.3. Modular Stepping Piezo Actuator MSPA	86
6.4. Rotary Stepping Piezo Actuators RSPA	87
6.5. Fine Stepping Piezo Actuator FSPA	88
6.6. Customised piezo motor mechanisms	89
6.6.1. Rotary stage	89
6.6.2. Long stroke linear stage	89
6.6.3. Long stroke curved stage	89
6.6.4. 3 axis closed loop mechanism	89
6.6.5. Space FSPA	89
<b>7. MAGNETIC ACTUATORS</b>	<b>91</b>
7.1. Moving Iron Controllable Actuator MICA™	92
7.2. Bistable Linear Moving Magnet BLMM	95
7.3. Tunable proof mass actuators	96
7.4. Specific magnetic actuators	97
7.4.1. Moving Coil Actuators MCA	97
7.4.2. Extra flat MICA™ stages	97
7.4.3. Specific Electro-Magnet Actuator EMA	98
7.4.4. Specific moving iron actuator	98
7.4.5. Asynchronous linear motor	99
7.4.6. Magnetic Fast Steering Mirror M-FSM	99
<b>8. DRIVE ELECTRONICS &amp; CONTROLLERS</b>	<b>101</b>
8.1. Amplifiers & controllers for piezo actuators	102
8.1.1. OEM series	102
8.1.2. Powered rack mounted series	104
8.1.3. Linear voltage amplifiers	106
8.1.4. Switching voltage amplifiers	106
8.1.5. Two States Power Amplifier	109
8.1.6. Digital controllers	110
8.1.7. Customised amplifiers and controllers	111
8.2. Amplifier for magnetic actuators	112
8.2.1. OEM series	112
8.2.2. Customised amplifiers & controllers	115
8.3. Controller for piezo motors	116
8.3.1. Controller board for stepping piezo actuator	116
8.3.2. Customised controllers for piezo motor based mechanisms	117

<b>9. SENSORS &amp; CONDITIONERS</b>	<b>121</b>
9.1. Selection guide	121
9.2. Strain gauges & associated conditioners	122
9.2.1. Strain gauge sensors	122
9.2.2. Strain gauges conditioners	122
9.3. Eddy Current Sensors & associated conditioners	124
9.3.1. Eddy Current sensor Probes ECP	124
9.3.2. Eddy Current Probe conditioners ECS	126
9.4. Customised sensors' solutions	128
9.4.1. Customised sensor's integration	128
9.4.2. Customised magnetic sensors & detection systems	128
9.4.3. Non-Destructive Testing NDT & Structural Health Monitoring SHM	130
<b>10. MECHATRONIC SOLUTIONS</b>	<b>133</b>
10.1. Evaluation Pack EP120S	134
10.2. Educational kit ACV - Active Control of Vibrations	135
10.3. Piezo motor developer kits	136
10.3.1. LSPA30uXS piezo motor developer kit	136
10.3.2. LSPS35XS piezo motor developer kit	136
10.3.3. MSPA35XS piezo motor developer kit	137
<b>11. APPLICATION NOTES</b>	<b>139</b>
11.1. Your own application selection guide	139
11.2. Building a general piezoelectric actuator model	142
11.3. Positioning Control of Piezo Actuators	143
11.4. EPC: Enhanced Peak Current	144
<b>INDEX</b>	<b>147</b>



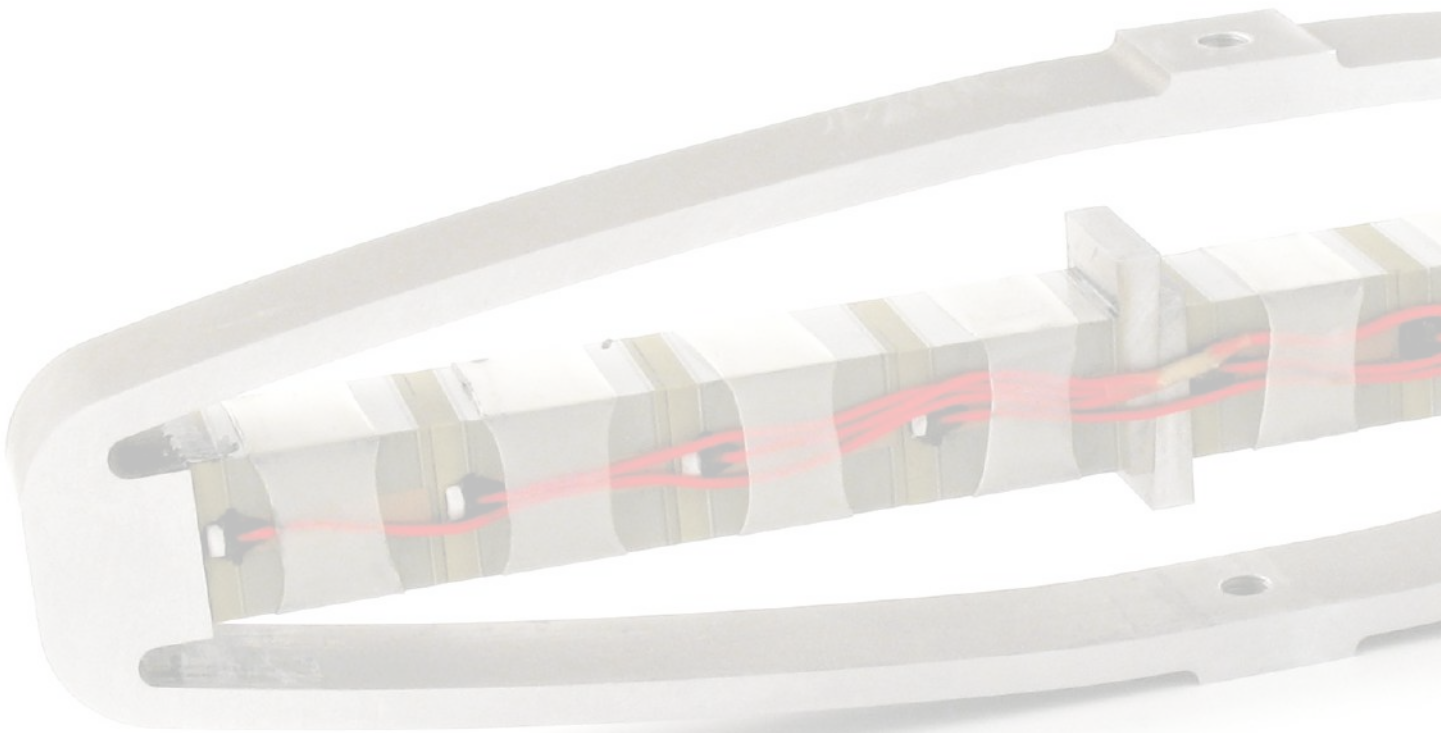

**For more information on this chapter,  
please visit these pages:**

[www.cedrat-technologies.com](http://www.cedrat-technologies.com)

[cedrat-tec.com/contacts/about-us](http://cedrat-tec.com/contacts/about-us)

[cedrat-tec.com/services](http://cedrat-tec.com/services)



# 1. CEDRAT TECHNOLOGIES ACTUATOR SOLUTIONS

## 1.1. INTRODUCTION TO PIEZO & MAGNETIC ACTUATORS FROM CEDRAT TECHNOLOGIES

CEDRAT TECHNOLOGIES (CTEC) has been constantly upgrading and enlarging its range of actuators and related electronic solutions since the middle of the 90s. In order to keep pace with its customers' needs and demands for efficient and robust mechatronic systems, CTEC has been developing **Compact, Dynamic and Precise** components through several families of products:

- Piezo actuators (APA<sup>®</sup>, PPA & mechanisms) working in strain mode,
- Piezo motors (SPA series) and stages (SPS series) working in stepping mode,
- Controllable magnetic actuators (MICA<sup>™</sup>),
- Bistable magnetic actuators (BLMM).

These actuators as well as the dedicated drivers, sensors and controllers are presented all along the sections of this catalogue. These actuators coupled with the relevant drive, sensor and controller offer a wide range of standard components and functions to build your own mechatronic systems and applications. In order to satisfy specific requests and demanding environments, CTEC can develop both customised components and mechatronic systems under your technical specifications, from building blocks briefly described here below.

To offer its customers the “state of the art” of products, some new products are given with “preliminary data”, which means that the product has been designed but has not been tested as much as requested by CTEC quality standards at the time of printing.

## 1.2. SYNTHESIS OF CEDRAT TECHNOLOGIES OFFER

All products from CEDRAT TECHNOLOGIES (CTEC) can be assembled to build a complete mechatronic system (Fig. 1.a).

CTEC offers a complete range of products, either standalone or OEM.

Note that mechanisms can produce larger stroke than the elementary actuators. All these electromechanical devices can be driven and controlled with the appropriate electronics.

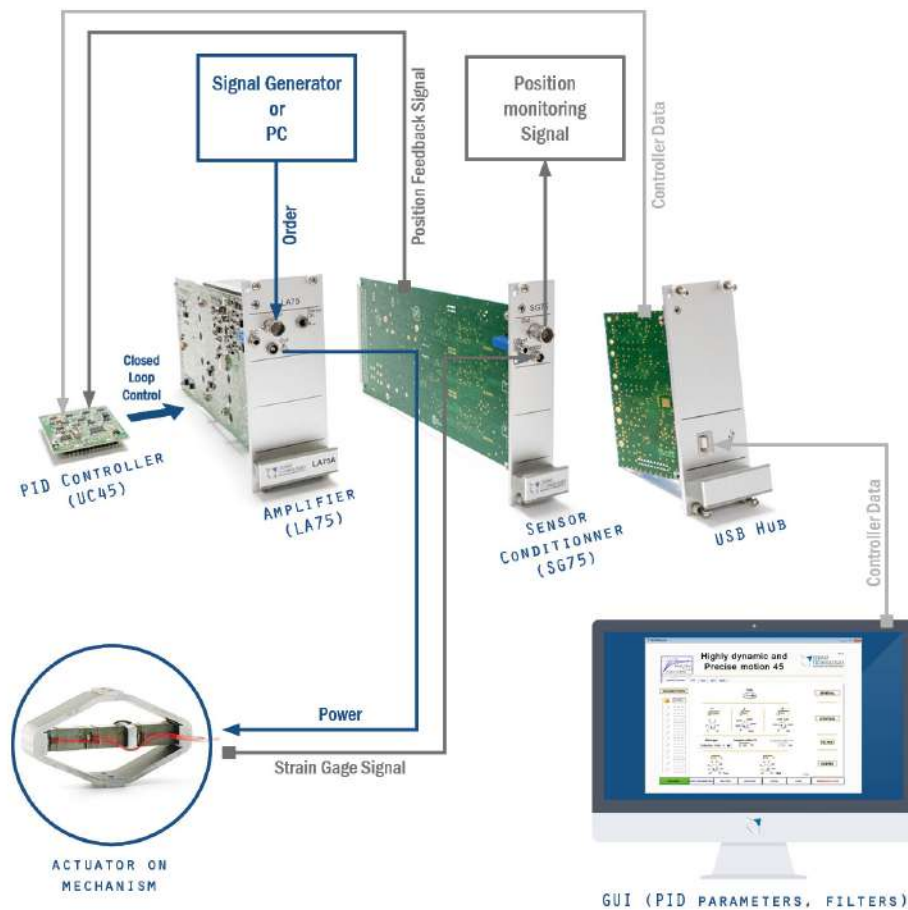

Fig. 1.a: Complete configuration: actuator, driver, sensor and control

### 1.3. OVERVIEW OF CEDRAT TECHNOLOGIES PRODUCTS & TECHNOLOGIES

CTEC's standard linear actuators cover a range of free displacements from 10  $\mu\text{m}$  to 10 mm and more (Fig. 1.b).

They have been designed in order to offer the largest possible stroke while keeping a reasonable size. The choice between these different solutions should be made regarding the need in force, displacement and working frequency.

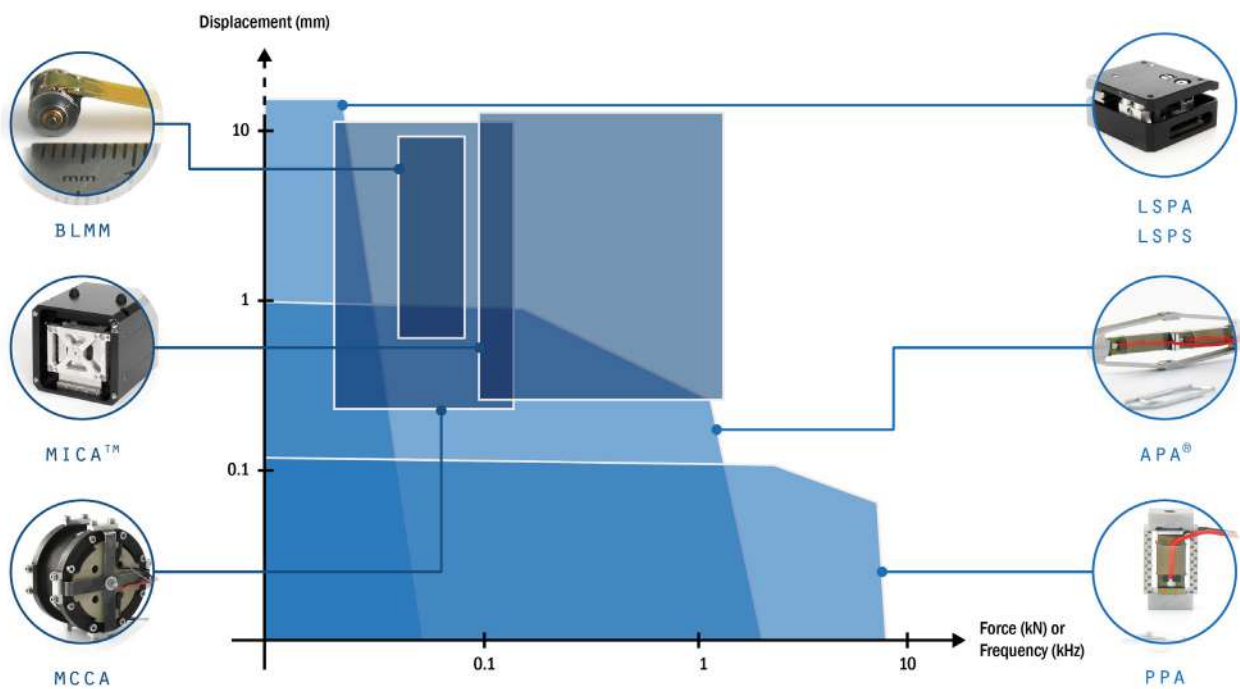

Fig. 1.b: CEDRAT TECHNOLOGIES range of products

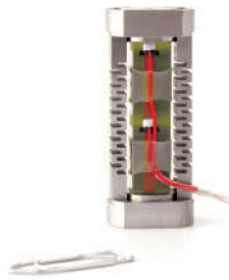

Fig. 1.c: PPA40L

### 1.3.1. PARALLEL PRE-STRESSED ACTUATORS PPA

PPA are solid-state linear actuators. They only use the expansion of the active material, in 33-mode, to produce a useful displacement. This displacement is proportional to the voltage within a 170 V range. Typically, the actuator's deformation is about 0.1% of its length (1  $\mu\text{m}/\text{mm}$ ), so their displacements are limited to about 100  $\mu\text{m}$ . However, the forces are naturally high, easily higher than 1 kN.

PPA use an external deformable frame to pre-stress the ceramics. PPA are cheaper, more compact, and display a much better dynamic behaviour than conventional direct piezo actuators.

More info on chapter 4.4, page 71.



Fig. 1.d: APA120ML

### 1.3.2. AMPLIFIED PIEZOELECTRIC ACTUATORS APA®

APA® are solid-state long-stroke linear actuators (Fig. 1.d). They are based on the expansion of the active material and on a mechanism to amplify the displacement. This amplified displacement is proportional to the voltage within a 170 V range. The advantages of APA® are their relatively large displacements combined with their high forces and compact size along the active axis. It leads to a deformation of 1% (10  $\mu\text{m}/\text{mm}$ ) or more. Therefore, their stroke may achieve up to 2 mm.

Thanks to their compactness, APA® can be stacked in series to reach longer strokes. Since APA® are robust, they can also be used in dynamic applications, including in resonant devices.

More info on chapter 4.2, page 60.

### 1.3.3. STEPPING PIEZO ACTUATORS SPA

SPA are another way to use APA®. SPA are long-stroke piezoelectric motors for micro/nano positioning applications benefiting from the APA® heritage. They operate by accumulation of small steps. Between each step the actuator is locked in position. It can also be operated in a deformation mode for a fine adjustment around a step position. In this mode the resolution is nanometric. SPA concept leads to different product families (LSPA, RSPA, LSPS...) which differ by their motion type (linear or rotating) and by the possible addition of a guiding like LSPA35XS stage.

More info on chapter 6, page 83.



Fig. 1.e: LSPS35XS

### 1.3.4. MOVING IRON CONTROLLABLE ACTUATOR MICA™

For applications where long strokes and highly dynamic actuators are required, CEDRAT TECHNOLOGIES (CTEC) develops magnetic actuators, the MICA™. With strokes up to 10 mm, forces up to 500 N, MICA™ are perfectly complementary products to our well-known piezoelectric offer.

MICA™ are robust, long lasting and powerful controllable actuators, with a force proportional to the current and can be used either for high frequencies or static applications. They come with an embedded position sensor and convenient mechanical interface for an easy integration.

They are the preferred option for high force continuous nonstop operations that require efficient heat sinking, and long lifetime fatigue requirements.

More info on chapter 7.1, page 92.

### 1.3.5. BISTABLE LINEAR MOVING MAGNET BLMM

BLMM actuators, are bi-stable actuators providing two locked positions at rest, without electrical power. Electrical power is required only to switch from one position to the other one, which is achieved with a very fast switching time, as per required in latching operations. Such actuators present high miniaturisation capabilities, as well as a high degree of response time performance tuning.

More info on chapter 7.2, page 95.

### 1.3.6. MOVING COIL ACTUATORS MCA

MCCA are the actuators having the best linearity performance achievable for very long stroke requirements beyond 10 mm. MCCA are the best controllable actuator reference for fine precision control and linearity, and are the preferred option for large motions in translation or rotation.

Compared to other technologies such as moving magnets and moving iron, moving coil actuators present some limitations with regard to heat dissipation, coil temperature, and flying electrical connection reliability.

### 1.3.7. SENSORS SOLUTIONS

CTEC has developed a deep know-how in strain gauge integration to control the displacement of piezo actuators. Demanding requirements, such as long term stability or vacuum environment compatibility can be achieved by this technology.

Also CTEC offers magnetic position sensors which provide a contactless distance measurement. Different technologies and topologies are proposed, to cover a wide range of applications, from nanometric to metric range. Some of these sensors can be integrated as standard to CTEC actuators and mechanisms in order to provide a position or state (open/close) information. For instance for PPA and APA® piezo actuators, strain gauges or Eddy Current Probes can be used depending on the precision required.

More info on chapter 9, page 121.



Fig. 1.f: MICA500L.



Fig. 1.g: ECS75-TS board

#### PRACTICAL APPLICATION: LONG TERM STABILITY MEASUREMENT

Some applications require a mechanism capable of nanometric resolution position tuning, and with the ability to maintain perfectly this position for a long time (more than several days). CTEC has managed to demonstrate the ability of a piezo-mechanism with integrated strain gages sensors to achieve nanometric position stability. This requires a specific set-up, particularly to stabilise the temperature variations below  $\pm 0.15^\circ\text{C}$  to measure displacements as small as one nanometre.

## 1.4. CEDRAT TECHNOLOGIES SERVICES & FACILITIES

CEDRAT TECHNOLOGIES (CTEC) heritage in space industry makes us used to work on complex problems in deep interaction with our customers.

From specific interface to dedicated design, through testing, system integration and assistance, our sales engineers help you all along your project.

### 1.4.1. ENGINEERING SERVICES

CTEC develops custom mechanisms for your actuating or sensing function. We can assist you with:

- Consulting and feasibility studies
- Modelling, design work
- Prototyping and testing
- Industrial projects leading to a turn-key solution
- R&D collaborative projects funded by the European Commission (H2020 projects) or other frameworks (Eureka, national projects)
- Manufacturing for the account of customers under QA (ECSS, MIL-STD, ANSI/IPC3)
- Technology transfers (Licensing)
- IP management and patent support

CTEC's know-how, facilities and experience allow its team to efficiently develop new actuators, sensors, mechanisms or high level mechatronic system.

CTEC performs step-by-step developments in partnership with its customers. Expertise, optimisation, design, prototyping, testing, manufacturing, any of these phases can be addressed to help our customers reaching their demanding application targets.

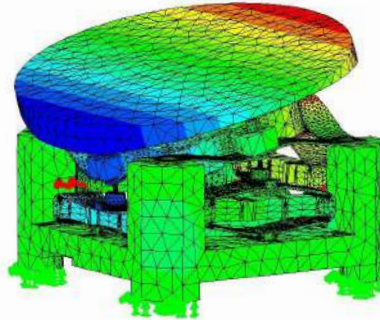

Fig. 1.h: FEA of piezoelectric FSM

Several new mechatronics technologies are being developed or are being improved: please do not hesitate to take a look at our website for any updated information.

In terms of service through a project, CTEC can also adapt an existing product or technology to new environmental conditions: thermal range, resistance to particular vibration spectrum, lifetime... as found in aerospace, medical, oil industries...

Some examples of applications are given in chapter 3, page 43 and at the end of chapter 4, page 57 to chapter 7, page 91.

#### OUR SCOPE OF EXPERTISE:

- Electromagnetism
- Piezoelectric
- Solid and fluid mechanics
- Thermal aspects
- Power electronics
- Controls
- System integration

### 1.4.2. PRODUCTION & LAB' CAPABILITY



Fig. 1.i: Production bench

CTEC makes thousands actuators and mechanisms a year for its customers. Integration and measurement of all mechatronic products are performed in our facilities in France (Meylan).

We can apply several quality standards (ECSS, MIL-STD, ANSI/IPC3).

Our production team routinely integrates batches up to several hundreds of pieces, using an adapted surface of 400 m<sup>2</sup> and an ISO7 or ISO5 clean room to comply with applications in ultra high vacuum (UHV) or integrating optics.

CTEC makes use of specialised test equipments for precise, high frequency displacement and environment testing of active devices:

- HP Impedance analyser used for the measurement of admittance curve, resonance and equivalent circuits,
- Several interferometres, vibrometres and autocollimators used to measure the actuator's main displacement & speed as well as parasitic displacement with high precision,
- Climatic and thermal vacuum chambers allow the analysis of thermal behaviour and/or of the effects of primary or ultra vacuum (such as Paschen effect).

Additionally, we work in collaboration with specialised laboratories and industries to answer to more specific needs, such as electrodynamic shaker or EMC measurement.

### 1.4.3. TECHNICAL ASSISTANCE & TRAINING



Fig. 1.j: Training at CTEC

CTEC can help you to turn your ideas into innovative projects. From training to dedicated assistance, we respond precisely to the way you wish.

Training are performed by CTEC's experts, using their experience in mechatronics or detection components and systems. They cover the fields of actuators, motors, transducers, sensors based on electric, magnetic, piezoelectric, magnetostrictive, MRF, ultrasonic effects or materials, electronics driving and control as well as their applications.

Detailed program and catalogue:

[cedrat-tec.com/services/training/technology-training](https://cedrat-tec.com/services/training/technology-training)

For more information about CTEC services, please visit:

[cedrat-tec.com/services](https://cedrat-tec.com/services)

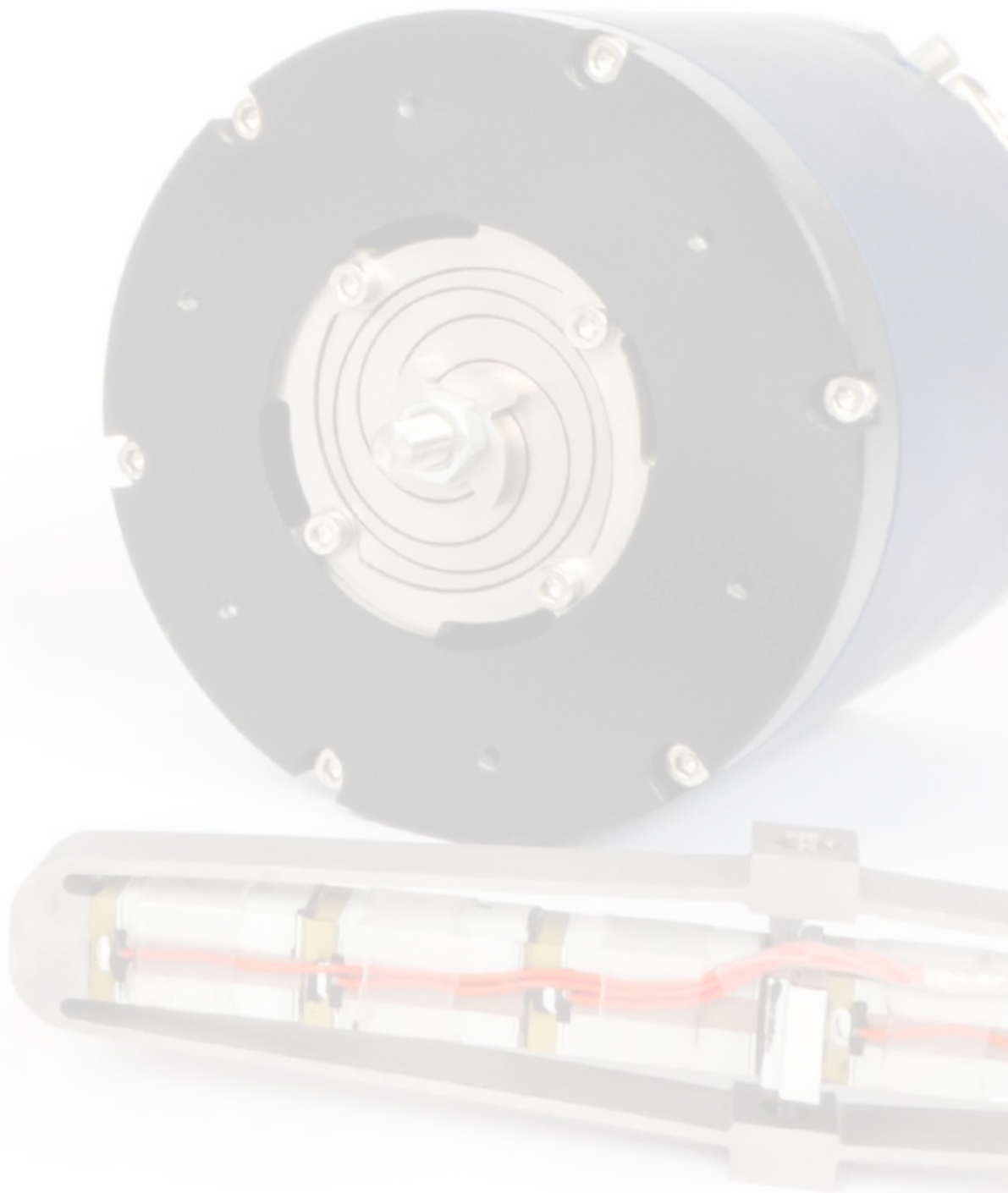

**For more information on this chapter,  
please visit these pages:**

[cedrat-tec.com/products/actuators](https://cedrat-tec.com/products/actuators)

[cedrat-tec.com/products/magnetic-actuators](https://cedrat-tec.com/products/magnetic-actuators)



## 2. TUTORIAL

### 2.1. TUTORIAL ON PIEZOELECTRIC ACTUATORS

#### 2.1.1. INTRODUCTION TO PIEZOELECTRIC MATERIALS

In 1880 the Curie brothers first examined the piezoelectric effect on crystal materials, which has the ability to produce electrical charges in response to externally applied forces. This is called the direct effect. This effect is reciprocal; meaning that the piezoelectric material changes its dimensions under applied electrical charges.

In 1922 Langevin proposed the first actuator based on crystal materials. To enhance its efficiency, this actuator was driven at resonance. The discovery of piezoelectricity in PZT (lead zirconate titanate) in the late 1960's increased the number of applications for industrial use. Piezoelectric transducers based on bulk PZT rings have been developed for sonar, ultrasonic welding, ultrasonic cleaning applications, etc. Sensor technology using piezoelectric ceramics (pressure or force sensors, hydrophones, accelerometers...) has matured since then. Based on piezoelectric bulk PZT rings, actuators for positioning purposes have also been studied. However, to obtain the deformation level required for this type of applications, it is necessary to use high input voltages. For instance, 0.5 mm thick PZT rings require an excitation voltage of approximately one thousand volts, which is clearly too high for several practical purposes. Multilayer Actuators (MLA), derived from the high capacitor technology, were introduced on the market in 1988 to circumvent the previous limitations. Because MLA are easy to operate, they have been increasingly used in various applications. The required excitation voltage of 150 Volts or less is well adapted to modern electronics.

These new materials are used by CEDRAT TECHNOLOGIES (CTEC) to build high energy density actuators and other devices, which are available either as standard or customised products, and which can be supplied with the dedicated electronics.

## 2.1.2. CHARACTERISTICS OF PIEZOELECTRIC MATERIALS

Piezoelectric materials are crystalline solids whose asymmetric structures create an electric dipole moment in the crystal lattice, which is sensitive to both the elastic strain and applied electrical field.

PZT materials are ferroelectric materials under the Curie temperature: the poling process gives the material its remanent polarization. During the poling operation, the material is subjected to a high electric field at the Curie temperature. If the material is subjected to a greater temperature than its Curie temperature, it is no longer piezoelectric. It can be epolarised to be piezoelectric again under certain conditions.

Stresses and strains are related to each other by the Young's modulus of the ceramic. In addition, a stress generates an electric field through the inverse piezoelectric effect. Since the ceramic is a dielectric medium, the electrical displacement is related to the electric field. These relationships can be combined in several sets of equations.

For example:

$$S_{\alpha} = s_{\alpha\beta}^E T_{\beta} + d_{n\alpha} E_n$$

$$D_m = d_{m\beta} T_{\beta} + \varepsilon_{mn}^T E_n$$

$\alpha, \beta = 1, \dots, 6$   
 $m, n = 1, 2, 3$

S: Strain

T: Stress

D: Induction

E: Field

$s^E$ : Compliances at constant field

d: Piezoelectric strains per unit of field

$\varepsilon^T$ : Permittivity at constant stress

The previous equations can be combined to define the electro-mechanical coupling coefficient, which can be seen as the ratio of the convertible energy to the total energy supplied to the piezoelectric actuator. Practical values of the material's coupling coefficient can be higher than 50 %, but in actuators, or in resonant transducers, the effective coupling factors  $k_{eff}$  are usually lower. The electromechanical coupling coefficient should not be regarded as the actuator's efficiency. The set of equations shown above does not take any loss into account. Commercial piezoelectric ceramics can be classified as soft-type or hard-type materials based on the ease or the

difficulty of depolarising them. Table 2.a lists some typical properties of active materials.

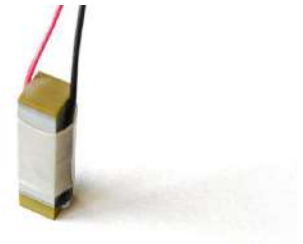

Fig. 2.a: View of a piezo ceramic stack (MLA)

Actuators made from single crystals or Electro-Active Polymer's (EAP) are still in their infancy, but may lead to new actuators in the future: their strain capabilities up to respectively 3 % and 300 % are outstanding.

Magnetostrictive materials like Terfenol-D are also studied at CEDRAT TECHNOLOGIES (CTEC). They expand when subjected to a magnetic field. Despite the losses occurring in the excitation coil, actuators based on this material may be well suited for very low-voltage or power applications. Customised actuators and transducers based on this material can be built by CTEC upon request.

Electrostrictive materials, such as PMN-PT also exist in multilayer. This material displays a low hysteresis (<2 %), but is much more temperature-dependent than PZT material.

## 2.1.3. ADVANTAGES & LIMITATIONS OF PIEZO ACTUATORS

- Their solid-state design with no rolling parts, so that they are not subjected to wear
- Unlimited resolution, making them ideal for nano-positioning
- Low power consumption
- Low heat dissipation
- High force / mass ratio, allowing their fast response time
- Possible non-magnetic option
- Possible operation in ultra high vacuum
- Possible operation in cryogenic temperatures
- Limited displacements range (below 2 mm)
- Limited to temperatures below 100 °C (or 150 °C in H.T. option), although some progress is being made for automotive applications

### 2.1.4. PARALLEL PRE-STRESSED ACTUATORS PPA

Direct piezo actuators are the most simple type of actuators: they consist of a stack of pre-stressed piezo ceramic. CTEC configuration consists in pre-stressing the MLA stack through an external elastic frame, leading to a Parallel Pre-stressed Actuator PPA.

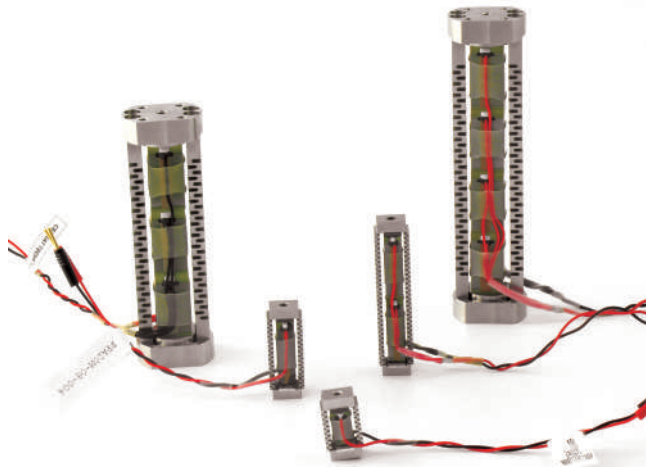

Fig. 2.b: View of PPA

PPA use the expansion of the active material, to produce a useful pushing displacement. As most of the energy strain is stored into the active material, the effective coupling

factor of this structure is high, generally higher than 50 %, as well as the elastic energy per unit of mass.

Because the pre-stress level of PPA is well controlled, they display a good dynamic behaviour and can be operated at resonance.

The displacement is roughly proportional to the voltage, from -20 to 150 V, which can be produced with special power electronics. The relation between the displacement and the voltage is not exactly linear because of the hysteresis of the active material. This effect can be well controlled with the appropriate feedback electronics, which linearise the system's behaviour.

As the strain of present piezo materials is limited to 0.12 %, the induced displacement is necessarily small, even with very long actuators. That is the reason why there is no direct piezo actuator offering 200 µm of stroke available on the market.

Due to non active pieces (end parts, prestress mechanism), the deformation of the actuator is smaller than that of the material itself, leading to values from 0.08 % to 0.10 % (0.8 to 1 µm/mm) in the PPA80L. Thus, a 100 mm long PPA can reach about 80 to 100 µm. The longest PPA can hardly be longer than 200 mm because of the risks of breaking in buckling. That is the reason why there is no direct piezo actuator 200 µm of stroke available on the market (in this case Amplified Piezoelectric Actuator APA® offer an alternative solution).

MATERIALS	CONTROL FIELD E ELECTRIC H MAGNETIC	YOUNG'S MODULUS AT CONSTANT FIELD (GPA)	MECHANICAL QUALITY FACTOR (QM)	ELECTRO- MECHANICAL COUPLING COEFFICIENT K33 (%)	QUASISTATIC MAXIMUM STRAIN (PPM)
<b>&gt; Bulk piezoelectric</b>					
PZT-8	E	74	1 000	64	+/- 110
PZT-7	E	72	600	67	-
PZT-4	E	66	500	70	+/- 150
PZT-5	E	48	75	75	+/- 300
Single-crystals (PZN-PT)	E	10	-	90	3 000
<b>&gt; Multilayered piezoelectrics (MLA)</b>					
Soft-type	E	45	25 - 50	70	1 250
Hard-type	E	62	200 - 500	60	800
<b>&gt; Electroactive polymers (EAP)</b>					
PVDF	E	1	20	30	1 000
Dielectric elastomers	E	1	-	-	3 000000
<b>&gt; Magnetostrictives</b>					
Terfenol-D	H	25	10 - 20	70	1 600

Table 2.a Properties of piezoactive materials

### 2.1.5. AMPLIFIED PIEZOELECTRIC ACTUATORS APA®



Fig. 2.c: View of an APA120S

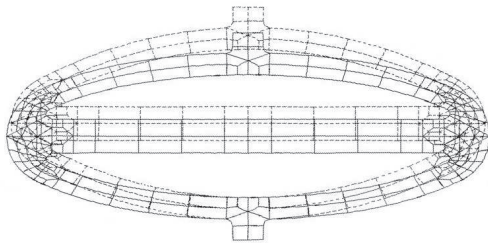

Fig. 2.d: Finite element computation of an APA®  
Dotted lines: Structure at rest  
Full lines: Structure deformed by the piezoelectric effect  
(Atila FEM result)

The displacement limitation of Parallel Prestressed Actuators PPA can be overcome thanks to an elastic mechanical amplifier. Various designs, most of them using flexural hinge, have been proposed in the past. Stresses become very high in the hinges during actuation, resulting in fatigue effects.

Amplified Piezoelectric Actuators APA® are based on a shell without any hinges. High displacements of APA® combined with high forces show that these actuators achieve displacement amplifications of 2 to 20 and have a good mechanical efficiency. Thanks to this amplification and to their shape ratio, they can achieve deformations from 1 % to 10 %. Note that their deformation for a positive voltage is a contraction, meaning that APA® are pulling actuators.

For example, at 150 V, the APA400M produces free displacements up to 400  $\mu\text{m}$  and blocked forces up to 38 N along its 14.3 mm short axis. It corresponds to a deformation of 2.8 % along the short (active) axis. This large deformation can also be found on large APA®: the APA2000L produces free displacements up to 2000  $\mu\text{m}$  and blocked forces up to 66 N, along its short axis, which is about 27 mm height, meaning 7.4 % deformation.

APA® present the following features:

- The actuators are small and compact relative to their strokes,
- The displacement magnification and the stiffness are functions of the eccentricity of the shell,
- It can be operated in a wide range of frequency including the resonance frequency,
- The bending behaviour of the shell under the piezoelectric actuation allows an acceptable distribution of stresses in the amplifier
- Bending and / or twisting moments can be exerted (to a certain extent) on the shell, which prevents the MLA from breaking. From this specific point of view, APA® are considered to be more robust than PPA.

## 2.1.6. STEPPING PIEZO ACTUATORS SPA

Stepping Piezoelectric Actuators SPA are new long-stroke piezoelectric motors for micro/nano positioning applications benefiting from the APA® heritage. The SPA relies on a simple design: an APA®, a front mass, a clamp and a rod. They operate by accumulation of small steps by stick-slip (step mode M1). Between each step the actuator is locked in position. When the long stroke is performed, it can also be operated in a deformation mode (M2) for a fine adjustment. In this case, the stroke is proportional to the applied voltage, which leads to a nanometre resolution and a high bandwidth.

To summarise, SPA offers:

- A stepping mode producing strokes of several mm,
- A blocking at rest in any position (locking without power supply), leading to a high stiffness,
- A nano positioning resolution all along the stroke,

The SPA can be driven by a one-channel CEDRAT TECHNOLOGIES linear amplifier, SPC45 (See chapter §8. *Drive Electronics & Controllers*, page 101).

Many SPA can be defined starting from the standard range of APA®. SPA find applications as micro positioning, locking mechanisms. They can be non-magnetic and/or vacuum compatible.

The SPA concept leads to different product families:

- LSPA: Linear Stepping Piezo Actuators
- RSPA: Rotating Stepping Piezo Actuators
- LSPS: Linear Stepping Piezo Stages, which are based on a LSPA and an additional linear guiding for removing transverse parasitic motion,
- MSPA: Modular Stepping Piezo Actuators, which provide a convenient way for integrating an LSPA in an already guided application,
- FSPA: Fine Stepping Piezo Actuators, which is an original variation of the LSPA that allows sub-micrometric stepping resolution combined with large forces.

All these products can perform in harsh environment:

- Wide temperature range (including cryogenic):  
- 200 °C to + 70 °C (70 K to 343 K)
- Vacuum
- External vibrations and shocks

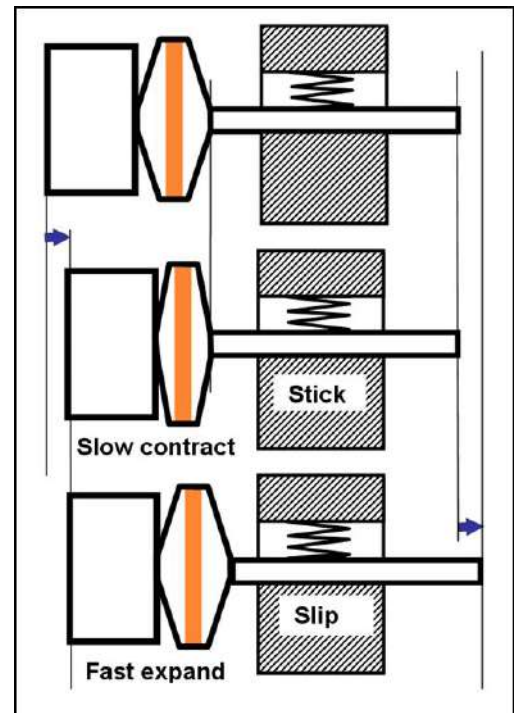

Fig. 2.e: View of LSPA

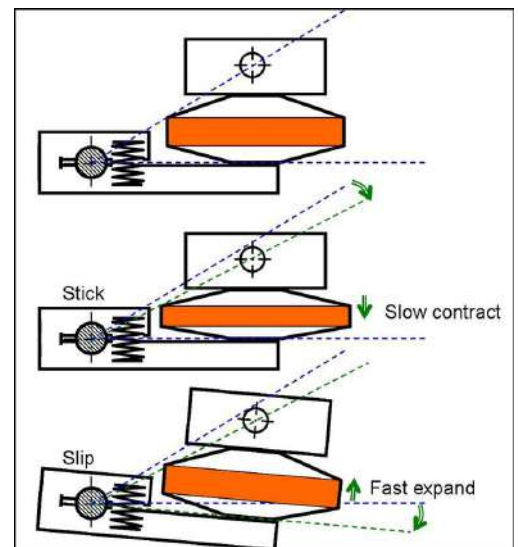

Fig. 2.f: View of RSPA

## 2.1.7. STATIC BEHAVIOUR OF PIEZOACTIVE ACTUATORS

This section gives some guidelines to choose the best Parallel Prestressed Actuator PPA or Amplified Piezoelectric Actuator APA® for quasi-static applications.

Two parameters define the actuator: the stroke  $\Delta U_0$  (defined as maximum displacement) and the blocked force  $F_0$  (max force at max voltage with no displacement).

With a stiffness:

$$K = \frac{F_0}{\Delta U_0}$$

and the force factor:

$$N = \frac{F_0}{V_{max}}$$

with  $V_{max}$ , the higher voltage value allowed for the actuator.

In most cases, the displacement  $\Delta U$  is the first interest, it is controlled by a voltage input  $V$  as follows:

- **Simple case:** If there is no load and no external force on the actuator, we can talk of free displacement:

$$\Delta U(V) = \frac{NV}{K}$$

when  $V=V_{max}$  by definition  $\Delta U(V_{max}) = \Delta U_0$ :

$$\frac{NV_{max}}{K} = \frac{F_0}{K}$$

- **Extended case:** If there is a load on the actuator, when we apply a voltage, a force  $F$  is generated on the load. The resulting displacement will be:

$$\Delta U(V) = \frac{NV - F}{K}$$

when the generated force  $F$  reaches  $F_0$ , with  $V=V_{max}$ , it is clear that the maximum possible displacement  $\Delta U(V_{max})$  becomes 0. (See Fig. 2.g)

**It means that the actuator cannot provide both the maximum displacement and the maximum force, but a single working point along the characteristic curve is defined.**

If a constant load  $F_{ext}$  (i.e. weight) is applied (smaller than the blocked force), it does not affect the stroke of the piezoelectric actuator, but only results in a shift of the maximum voltage position to a distance  $\Delta L$ :

$$\Delta L = \frac{F_{ext}}{K}$$

And the maximum displacement in this situation becomes (see Fig. 2.h):

$$\Delta U_0 - \Delta L$$

A very different situation occurs when the piezoelectric actuator acts against a spring with a stiffness  $K_t$  (see Fig. 2.i).

The stroke becomes:

$$\Delta U = \frac{NV - K_t \Delta U}{K}$$

that gives:

$$\Delta U = V \frac{N}{K + K_t}$$

And with the maximum voltage  $V=V_{max}$ :

$$\Delta U = \Delta U_0 \frac{K}{K + K_t}$$

Piezoelectric actuators can be mechanically arranged in series and/or in parallel. In the first case, displacements are added and the force stays constant, while in the latter, the forces are added and the displacement remains the same (see Fig. 2.j and Fig. 2.k).

### 2.1.8. DYNAMIC BEHAVIOUR OF ACTUATORS (LOW LEVEL)

Which is the effect of electromechanical resonance on actuators?

If either the applied voltage or the external force varies with the time, the displacement still follows the excitations until dynamic behaviours appear. The previous relationships remain valid in the quasi-static bandwidth, which is limited by about one third of the resonance frequency. If the actuator is unloaded, the resonant frequency is:

$$f_r = \frac{1}{2\pi} \sqrt{\frac{K}{m}}$$

where  $m$  is the effective mass of the piezoelectric actuator. If the actuator is loaded with an additional mass  $M$ , the resonance frequency  $f_r$  then becomes:

$$f_r = \frac{1}{2\pi} \sqrt{\frac{K}{M + m}}$$

The resonance frequency is also affected by external masses, spring constants or damping effects.

Dynamic operations are more complex because of the acceleration acting on the piezoelectric actuator. Displacements (and consequently stresses) can become very high.

At resonance, considering a constant voltage amplitude, they are magnified by the mechanical quality factor  $Q_m$ :

$$\Delta U_0 = Q_m \frac{NV}{K}$$

The values of the  $Q_m$  factor depend on many parameters coming both from the actuator and the load. Typical values are in the range of 20 (high level) to 200 (low level) under free condition. They decrease in case of resistive load (load exhibiting damping or energy radiation).

The settling time  $t_s$  of the actuator is limited by the resonance frequency  $f_r$ :

$$t_s \approx \frac{1}{f_r}$$

In practical situations, the settling time of the actuator can be limited by the charging time value of the electronics.

*Note: The use of piezo actuators under dynamic conditions requires a careful design and a lot of experience, because of the mechanical breaking risks.*

Please do not hesitate to contact CEDRAT TECHNOLOGIES (CTEC) for design and tests or to use CTEC CADs for preliminary analysis.

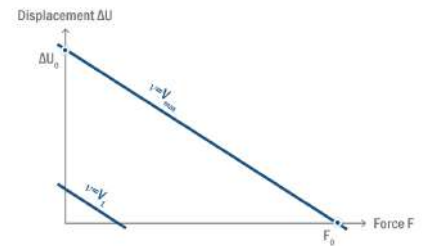

Fig. 2.g: Load characteristics of a piezoelectric actuator

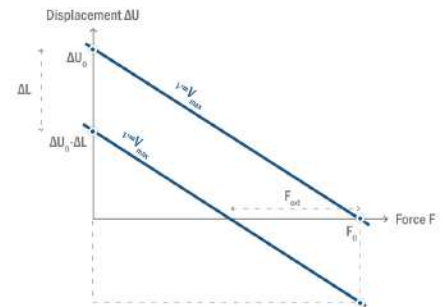

Fig. 2.h: Position shift and load characteristics of the actuator under a constant force

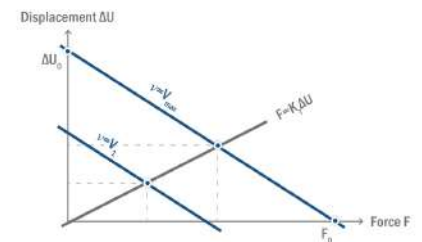

Fig. 2.i: Load characteristics under a spring with a stiffness  $k_s$ .

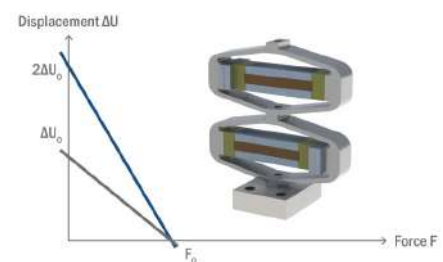

Fig. 2.j: Series arrangements of APA®

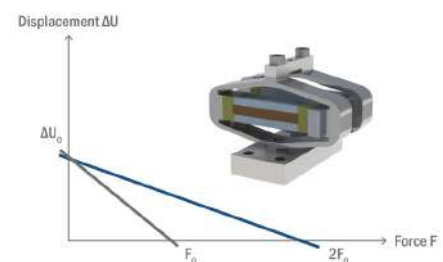

Fig. 2.k: Parallel arrangements of APA®

## 2.1.9. LIMITATIONS OF PIEZOELECTRIC ACTUATORS

Piezoelectric actuators have several limitations that must be taken into account in order to properly design the applications. These limits are electrical, mechanical and thermal. The impact of these limits depends a lot on the frequency region the actuators are used in (see Table 2.b). These frequency regions are governed by the requested function and applications.

### ELECTRICAL LIMITS

The maximum voltage range is limited between -20 V +150 V. Out of this range, the piezo ceramic will be either reversed in polarisation or electrically breakdown.

In static operations (S region), their lifetime is mainly limited by the combination of DC voltage and humidity, which penetrates through the external insulation layer and leads to an increase in current leakage. A larger current leakage can lead to an electrical breakdown.

In dynamic strain non-resonant operation (DS region), electrical limits may be encountered. Because of the capacitive nature of piezo actuators, the higher the frequency is, the higher the current is (see chapter 2.1.10, page 27). This current need may reach the power amplifier limits. To solve this problem CEDRAT TECHNOLOGIES (CTEC) develops high power linear and switching amplifiers.

### MECHANICAL LIMITS

In dynamic operations, especially in resonance region (R), the piezo actuator mechanical stress limits may be encountered. To avoid tensile forces during dynamic operation a well defined mechanical pre-stress is applied on all the piezo actuators from CTEC.

The level of pre-stress is responsible of the force limit (0-peak), or max dynamic peak force for the limitation of the actuator's stroke (or its vibration amplitude).

Examples of impacts of electric or mechanical limits on an actuator's capabilities:

The advantage of a high pre-stress is shown with the APA120ML example under blocked-free conditions, loaded with a 180 gr mass.

*Note: The blocked-free condition means that one interface is fixed to a rigid body and the other interface of the actuator is free to move the load. The free-free condition is where the two interfaces of the actuator are free to move.*

This offers a static stroke of 130  $\mu\text{m}$  @ 170 V, so 0.76  $\mu\text{m}/\text{V}$ . Its blocked force is 1400N so 8.2 N/V. Its loaded resonance frequency is 1 kHz. The graphs of Fig. 2.l show the actuator response in harmonic analysis (sine excitation) and the 4 frequency regions. Thanks to the nominal high pre-stress of the APA120ML, the maximal dynamic peak force can reach 700 N (Fig. 2.m).

Thus the maximal dynamic stroke below resonance (DS region) is higher than its maximal static stroke, while the stroke at resonance (R region) is similar to the static stroke (Fig. 2.n and Fig. 2.o). It gives a very large bandwidth for displacement generation. Dynamic forces above resonance (DF region) can reach the blocked force. All these dynamic properties are important for non-resonant dynamic applications such as forced vibration generation or active damping, as well as for resonant applications such as vibration generation at resonance.

REF	FREQUENCY REGION	BANDWIDTH DEFINITION
S	Static & quasistatic	From 0 to $F_r/3$
DS	Dynamic Strain	Between $F_r/3$ and resonance region
R	Resonance	3 dB-bandwidth around mechanical resonance frequency $F_r$
DF	Dynamic Force	Frequency above resonance region
I	Impulse (S + DS + R + DF)	Whole frequency spectrum

Table 2.b Different methods to use piezoelectric actuators



For the same reason, the APA120ML can survive large external vibrations and has successfully passed space qualifications. To improve even more the ability to generate or withstand dynamic movements in APA®, CTEC proposes

If a 10 times lower pre-stress were applied on the APA120ML, the maximal dynamic peak force (in DS region) could only reach 70N and so the maximal dynamic stroke at resonance (R) and below resonance would be much

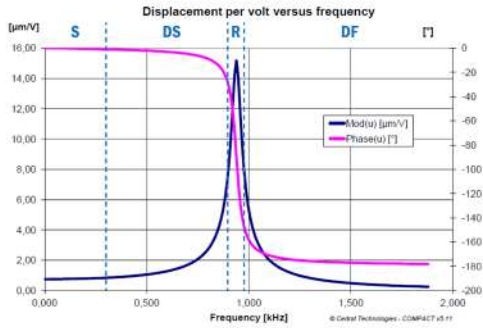

Fig. 2.l: APA120ML in blocked-free conditions, loaded with a mass of 180 gr: Displacement per volt versus frequency (See Table 2.b)

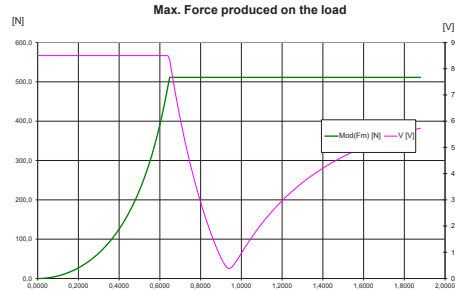

Fig. 2.m: APA120ML in blocked-free conditions, loaded with a mass of 180 gr : Maximal forces vs frequency

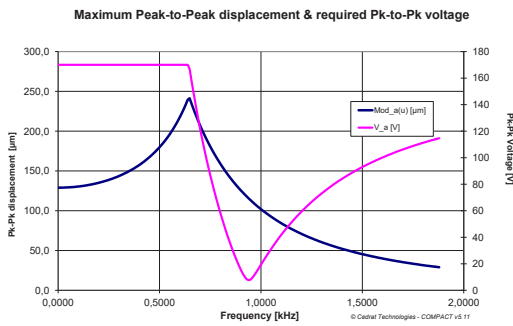

Fig. 2.n: APA120ML in blocked-free condition, loaded with a mass of 180 gr: Maximal displacement and maximal applicable voltage versus frequency.

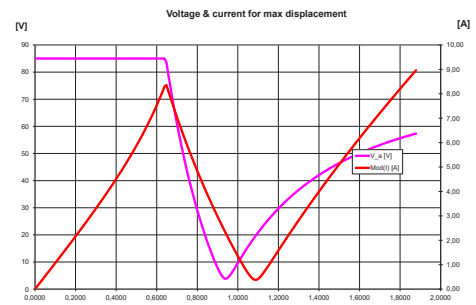

Fig. 2.o: Requested peak voltage and peak current to reach the displacement of Fig. 2.o

solutions such as the Parallel Pre-stress Actuator PPA.

smaller than its maximal static stroke (Fig. 2.p and Fig. 2.q).

*Note: below resonance, the displacement can be higher than at resonance, but the needed current is high, which may reach the power limit of the electric amplifier.*

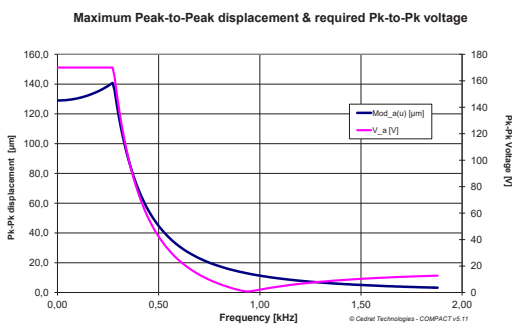

Fig. 2.p: Modified APA120ML with a low pre-stress (90 % less than nominal) under blocked-free conditions, loaded with a mass of 180 gr: Maximal displacement and maximal applicable voltage versus frequency.

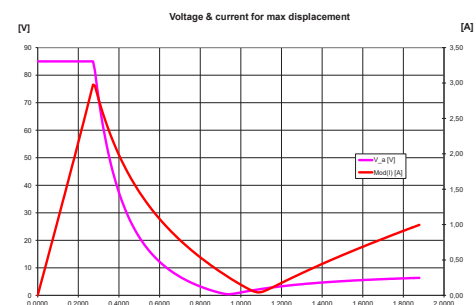

Fig. 2.q: Requested peak voltage and peak current to reach the displacement of Fig. 2.p

Note also that APA® with large amplification as the APA900M have reduced pre-stress. That is why their maximal dynamic stroke in DS an R region is lower than their static stroke in S region, even much below resonance. It limits their application to quasi-static conditions. Therefore an APA200M can produce more displacement at 100 Hz than an APA900M, although he an APA200M static stroke is smaller (Fig. 2.r and Fig. 2.s).

Impulse applications found for example in injectors and shutters are the most complex cases regarding an actuator's limits. In these applications, a step excitation signal is typically used. This causes overshoots which clearly excite resonance and can break the actuator.

Impulse response is due to a transient excitation signal. It can be analysed as a spectrum of frequencies by Fourier Transform. This signal spectrum can be multiplied with the above transfer functions to get the actuator's response. Thus an impulse excitation uses the actuator under dynamic conditions combining resonance and non resonance frequency regions (DS, R, DF), which generates a lot of stresses in the actuator. For this reason, high-prestressed actuators are preferable to get a long life time under Impulse strain conditions. In safety preloading conditions the life time of CEDRAT TECHNOLOGIES (CTEC) piezo actuators is higher than 10 billion cycles.

## THERMAL LIMITS

Due to the dielectric and mechanical losses, the piezoelectric actuator warms up under continuous excitation. Losses are mainly non-linear and depend on the excitation frequency, the voltage amplitude and the humidity level. To avoid a depoling effect of the ceramic, the temperature in the actuator should be monitored to ensure that it stays well below the ceramic's Curie temperature. So the typical temperatures range from -40 °C to +80 °C.

As a consequence, the duty cycle of a piezoelectric actuator in dynamic operation is limited by its thermal behaviour. For instance, to maintain a constant temperature on the APA60SM actuator, the duty cycle should be reduced or a forced convection should be applied as the driving frequency increases. There are currently a lot of researches on materials that aim at producing MLA displaying higher working temperatures (up to 200 °C). Upon request, CTEC can produce actuators with these new components.

Similarly, the standard MLA work at low temperature and have already been tested in liquid nitrogen (77 K, -196 °C): at this cryo-temperature, their strain is only one third of the one obtained at room temperature. As a consequence, PPA and APA® offer a reduced stroke; LSPA, LSPS present a reduced speed.

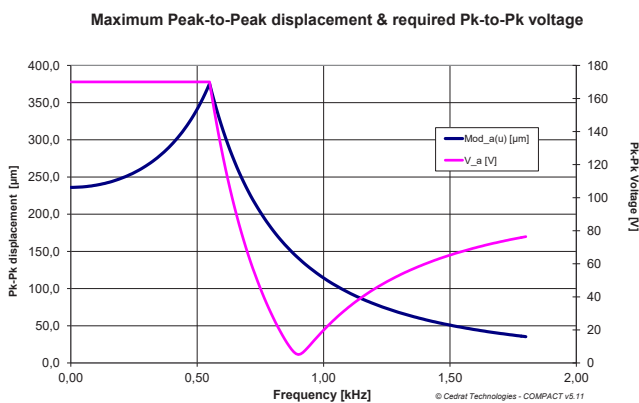

Fig. 2.r: APA200M in blocked-free condition, unloaded:  
Maximal displacement according to prestress and maximal applicable voltage versus frequency

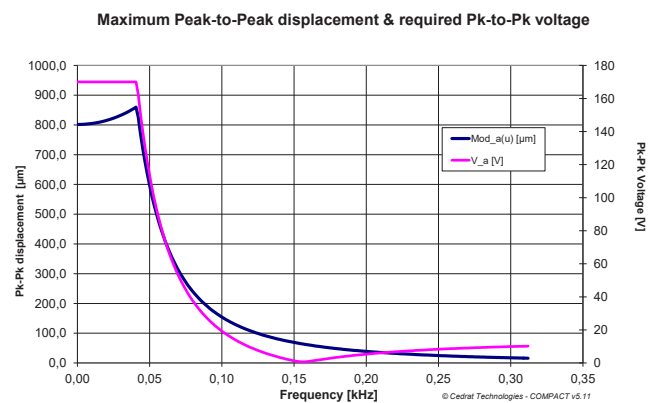

Fig. 2.s: APA900M in blocked-free condition, unloaded:  
Maximal displacement according to pr/stress and maximal applicable voltage versus frequency

### 2.1.10. DRIVING OF PIEZOELECTRIC ACTUATORS

A piezoelectric actuator is a capacitive device, whose capacitance is often very large (as much as 110 μF). Such a device is a difficult load for its driving electronics, since a significant charge transfer rate is necessary to achieve a fast response. In addition the actuator will produce electrical energy when submitted to a mechanical load.

Linear amplifiers are the most common amplifiers and have high signal to noise ratio. Switched power amplifiers are more efficient under reactive loading in dynamic applications, but have frequency limits due to switching. The general synoptic of the driving system for a piezoelectric system is given in Fig. 2.t.

With a linear amplifier the voltage applied to the actuator is directly proportional to the input signal. The gain of the power amplifier is set to 20.

- Input signal: -1 V to +7.5 V
- Output signal: -20 to 150 V

Indeed, when the variation speed of the input signal (order) increases, the current limitation  $I_{lim}$  of the amplifier limits the slew rate of the output voltage.

The current for a capacitive load is given by the following expression:

$$I_{piezo} = C_{piezo} \frac{dv}{dt}$$

where  $v$  is the input voltage and  $C_{piezo}$  is the quasistatic capacitance of the piezo actuator.

For a given current limitation  $I_{lim}$ , the shortest charging time is given by:

$$t_{charge} = \frac{\Delta V \cdot C_{piezo}}{I_{lim}}$$

where  $\Delta V$  is a peak to peak voltage value,  $\Delta V = 2V_p$

and  $V_p$  is the peak value of the sine voltage applied to the actuator.

In dynamic operation, the peak current  $i$  flowing into the actuator linearly increases with the frequency of a sine signal.

$$i \approx 2\pi f C_{piezo} V_p$$

Due to the peak current limitation, the maximal frequency for a sine signal is given by:

$$f_{sin\ max} = \frac{I_{lim}}{\Delta V \cdot C_{piezo} \pi}$$

The required effective electrical reactive power  $Q$  is equal to:

$$Q \approx 4f C_{piezo} V_p^2$$

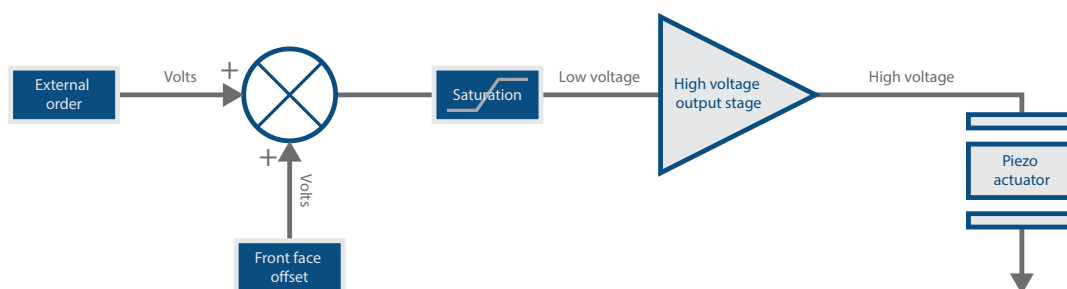

Fig. 2.t: Synoptic of driving system

Note: One option available on the linear driver is the push-pull operation, which can be used to drive tilt devices or electrically centered mechanisms (Fig. 2.u).

The resolution of a piezoelectric actuator is limited by the electrical noise of the driving system. Typical values of the signal to noise ratio of the driving electronic (below the resonance frequency of the actuator) range from 70 to 85 dB.

MLA always display an hysteresis, which limits the positioning accuracy. Other effects, such as drift, also limit the actuator's linearity. Therefore, displacement sensors are often used to ensure a linear response of the piezoelectric actuators through a closed-loop (Fig. 2.w).

When accuracy or speed is required, additional controllers are implemented in specific control loop to improve the performances of the piezoelectric mechanisms. Coupled with Strain Gauges sensors (SG75 conditioner option) or Eddy Current Sensor (ECS75 conditioner option), the servo controller (UC45 or UC55) is ideally the best solution to control the displacement or to reduce the settling time of the actuators by regulating the applied command.

See application note "Position control of piezo actuators" for more information on control : [cedrat-tec.com/products/users-manual/electronics.html](http://cedrat-tec.com/products/users-manual/electronics.html)

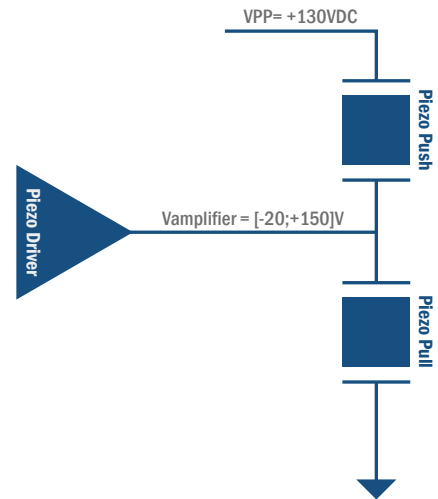

Fig. 2.u: Push-pull operation using one electric driver

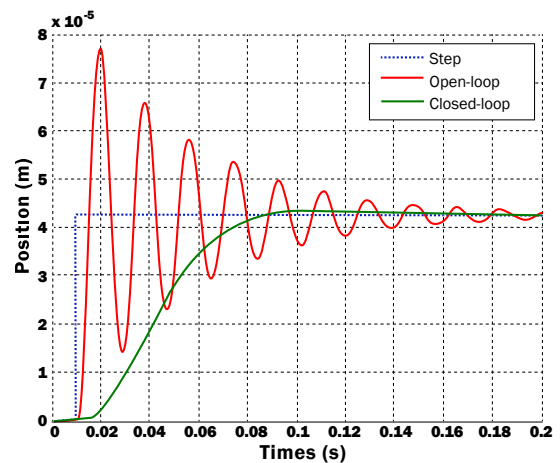

Fig. 2.v: Comparison between open loop and closed loop responses

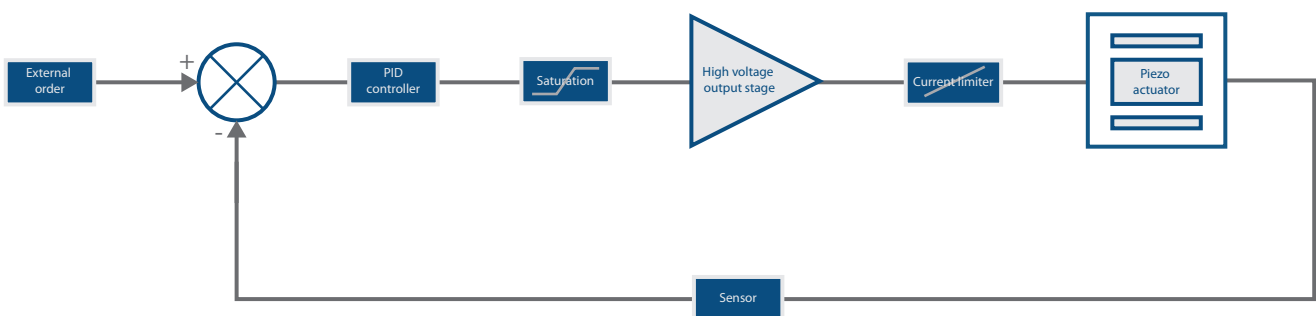

Fig. 2.w: Synoptic of a closed loop system

## 2.2. TUTORIAL ON MAGNETIC ACTUATORS

### 2.2.1. INTRODUCTION TO MAGNETIC ACTUATORS

Magnetic actuators are based on different magnetic design principles, which produce magnetic forces, in order to generate motions, such as displacement or acceleration, mechanical power, or static forces.

The magnetic forces production is achieved by the use of a combination of coils, driven by a current or a voltage in order to convert electrical power, soft magnetic materials for the conducting of magnetic fields, and hard magnetic materials i.e. permanent magnet, to generate efficient magnetic polarisation.

The magnetic principles allow to take benefit of two different types of forces to define actuators topologies, which are the Laplace Forces, and Reluctant forces.

**Laplace force actuators**, commonly named “**voice coil actuators**”, are based on the force resulting from the interaction of current in coil wire and a magnetic source (resultant of all Lorentz forces on electrons) (see Table 2.c). Such actuators can be realised either with moving coils or moving magnets topologies (i.e. fixed coils) (see Fig. 2.x). The Laplace force is proportional to the magnetic field B in the air gap.

$$F_{mag} = B_0LI$$

**Reluctant force actuators** (see Table 2.c), are based on the force resulting from the law of physics, which generates forces in order to minimise magnetic energy, in an air gap between two parts within a magnetic circuit. This law of physics results in an attraction force between the two parts, which is proportional to the square of the magnetic field  $B^2$  in the air gap. Such actuators can be realised either with moving magnets or moving irons (i.e. fixed coils and magnets such as “**MICA™**”) or even without magnets (i.e. “**Electro-Magnets**”), and have a higher force capacity compared to Laplace actuators (Fig. 2.y).

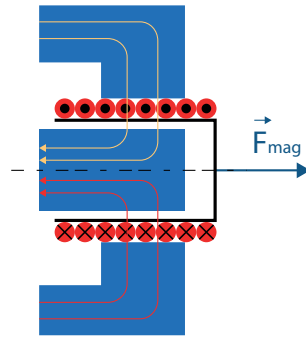

Fig. 2.x: Laplace force (Moving coil actuator)

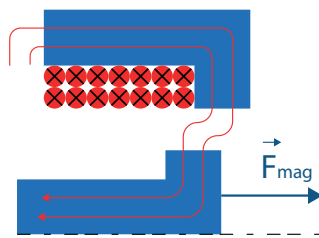

Fig. 2.y: Reluctant force (Moving iron actuator)

$$F_{mag} = B^2 \frac{S}{2\mu_0}$$

According to the possible combinations’ topologies of these materials, quite different functions and properties are obtained.

Magnetic actuators properties are strongly influenced by the mechanical implementation of moving parts, and the type of motion guiding devices such as compression/traction springs, flexure bearings, sliding bearings, ball bearings, or gas bearing. In most cases, guiding devices present stiffness that have to be taken in account in the available output force analysis. Net force usefull for the application is :

$$F = F_{mag} - ku$$

	MCA (VOICE COIL )	MICA™	ELECTRO-MAGNET	BI-STABLE
Locking at rest	<b>No</b>	<b>No</b> in standard <b>Yes</b> , 1 or 2 positions with custom design	<b>No</b> <b>Yes</b> , with spring	<b>Yes</b> , 2 positions
Magnetic Force when supplied	<b>Almost constant</b> along the stroke	<b>Rather constant</b> along the stroke	<b>Varying a lot</b> along the stroke	<b>Varying a lot</b> along the stroke
Motion Controllability	<b>Good</b> Force can be reversed all along the stroke; Small Hysteresis	<b>Good</b> Force can be reversed all along the stroke Small Hysteresis	<b>Poor</b> Only attractive force available	<b>No</b> Intermediate position cannot be controlled
Heating	<b>Fast</b>	<b>Slow</b>	<b>Slow</b>	<b>Fast</b>
Force / power	<b>Fair</b>	<b>High</b>	<b>High</b>	<b>Very high</b>

Table 2.c Magnetic actuators

## 2.2.2. MOVING COIL ACTUATORS MCA

The **Moving Coil Actuators MCA** are based on the Laplace force magnetic principle, which is proportional to the applied current  $I$  and magnetic field  $B_0$ .

$$F_{mag} = B_0LI$$

A MCA is composed of a fix part called stator, and a moving part. The stator is built with an assembly of magnets and magnetic circuits (soft materials), that create a static magnetic field  $B_0$ . The moving part is a coil. When supplied by a current this coil is submitted to a Laplace Force, i.e. the resultant of all Lorentz Forces applied on electrons, and can move in both linear directions according to the current direction (Fig. 2.aa) .

The force being proportional only to current and magnetic field, a good linearity of force versus position of the coil is achieved (Fig. 2.ab), at low stroke and force levels, leading to a high fidelity in response without distortions. Therefore MCA have been widely used in loud speakers, called "Voice Coil", due to this high linearity behaviour in the high frequency domain, where low forces and low strokes are required.

At higher stroke and force level with low to medium frequencies, this linearity performance decreases due to side effects, imperfect winding patterns, non-homogenous magnets' assemblies, and non-parallel line of field in large air gaps due to the coil thickness.

MCA are well suited for long stroke and high precision positioning requirements, when compactness, input electrical power, and operation time, are not the main drivers for a given application.

Indeed, the flying moving coil in an air gap makes it not possible to cool it by conduction, and makes it impossible to cool in vacuum condition, as well as in confined environment with no forced air convection. Continuous operations are then not possible, operating duty cycle shall be studied vs temperature.

MCA's design compactness, and electrical input power, are difficult to optimise, especially for long strokes, due to the flying coil having only partial immersion into the magnetic field, while powered entirely. This results in poor compactness, as well as reduced efficiency and higher heat dissipation by Joules effect, compared to other actuators.

The main advantage of the MCA is the mechanical simplicity of the magnetic circuit, that do not need any laminations for Eddy current losses optimisation, and that generates only little parasitic radial forces onto the moving part.

The moving coil requires special care on to the flying wire electrical lead connections, which are submitted to cyclical fatigue at high temperature, and which do not make such actuators compatible with free of maintenance, and long life nonstop continuous operations over years.

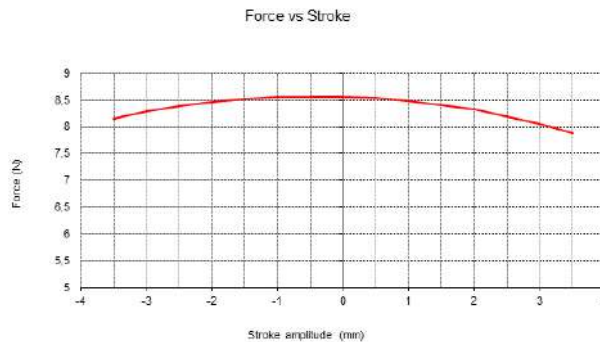

Fig. 2.z: Moving coil linearity of force versus stroke

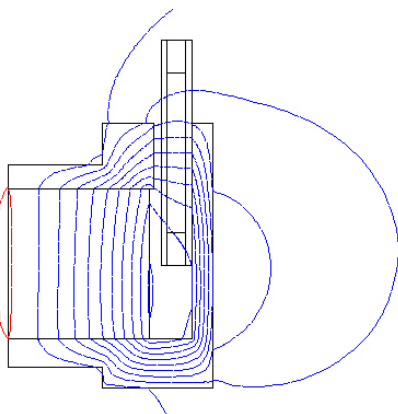

Fig. 2.aa: Moving coil magnetic principle



Fig. 2.ab: 100 N Moving Coil Actuator



Fig. 2.ac: 15 N Moving Coil Actuator

### 2.2.3. CONVENTIONAL MOVING IRON ACTUATORS - ELECTROMAGNETS

The **electromagnet actuators**, which include “**Solenoid**” actuators, are based on reluctant forces, with an actuator topology defined without magnets, i.e. only coils and soft materials, which require very simple mechanical designs.

The stator is built by assembly of coils and magnetic circuits, defining a one pole magnetic architecture resulting in a single force direction (attraction). The moving part, also called “**Plunger**”, is a soft magnetic core, typically an Iron alloy, which allows classifying such actuators in the category of **Moving Iron Actuators**.

When the coil is supplied by a current  $I$ , an attractive magnetic force  $F_{mag}$  is developed in the air gap between the plunger and the electromagnets actuator poles. For actuators with stroke perpendicular to the air gap  $F_{mag}$  is given by :

$$F_{mag} = B^2 \frac{S}{2\mu_0}$$

$B$  is the magnetic field in the air gap and  $S$  is the pole surface.

The force is only attractive, whatever the current direction. This force is highly nonlinear versus the plunger position, which cannot be controlled without implementing a spring back force, using a mechanical flexure bearing, or a compression spring, in order to generate an equilibrium position at a given current value.

The force and stroke available from such actuators are very high compared to their very small size, which make it especially attractive for miniature and fast position switching and control applications, such as on/off and fast regulation valves in fluid applications.

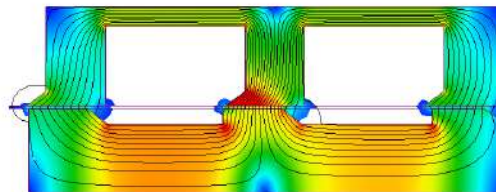

Fig. 2.ad: Electromagnet for proportional force to current actuation

In order to generate a position proportional to the current, at first the moving part is attached to a spring generating a back force. Secondly, the reluctant force non linearity versus position can be partially suppressed in a given stroke range using FEM optimisation of poles shape.

The main performance of such an actuator, compared to other magnetic ones, is the force response time performance achieved over very compact and light moving part, which makes it best applicable for demanding fast operational requirements.

This performance can be increased to best possible using current shaping drive electronics, which allow suppressing the field setting time due to Eddy currents in the magnetic circuit, as well as the mechanical response time of the moving plunger mass, by generating a transient force profile with a high peak value.

A current shaping electronic method can be used to increase speed, and reduced response time to reach a plunger position in proportional control, or a closing position, as well as to reduce shock impacts on end stops at closing, or for any combination of both.

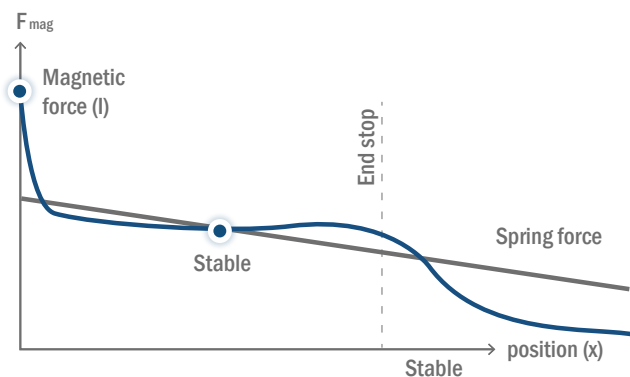

Fig. 2.ae: Proportional linearisation sizing

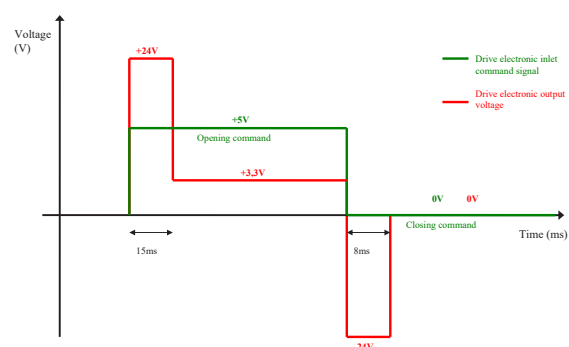

Fig. 2.af: Current shaping profile

## 2.2.4. MOVING IRON CONTROLLABLE ACTUATORS MICA™

**Moving Iron Controllable Actuators MICA™** are based on reluctant forces, as per electromagnets, but with a magnetic topology polarised with permanent magnets, in order to achieve a variable reluctance according to the current direction (Fig. 2.aj). This topology allows a force and motion direction change, according to the current direction, as per Laplace force actuators.

$$F_{mag} = B_d \frac{B_s S}{\mu_0}$$

where  $B_d$  is the dynamic magnetic field in the air gap due to the coil current,  $B_s$  is the static magnetic field due to the permanent magnets and  $S$  is the pole surface.

This formula (strictly valid when the actuator is centred) shows the force is proportional to the coil current. As shown on Fig. 2.ah and Fig. 2.ai, a good proportionality is even achieved in large ranges of positions and currents around the centre and the zero current.

This “**Variable Reluctance**” magnetic principle allows the **MICA™** to be classified in the category of “**Permanent magnet based actuators**”.

The MICA™ achieves a performance breakthrough, compared the weaknesses of the former state of the art on moving coil one, especially in terms of efficiency, compactness, and long life nonstop continuous operations over years without maintenance.

This enhanced feature is achieved by the use of a magnetic principle having both coils and magnets fixed (Fig. 2.ak), allowing an efficient heat dissipation by conduction. Moving Iron parts have compact dimensions and low mass compared to moving coils. Finally moving parts need no electrical connection nor heat dissipation.

Compared to former voice coil technology, this actuator topology offers a higher force per mass and per input power. This allows a long term operation at stabilised low coil temperature, as well as optimum electrical input power with reduced coil Joules effect. Best electrical efficiency performance is achieved by optimization of eddy current losses in both fixed and moving Iron assemblies.

The MICA™ mechanical simplicity allows design configuration over wide range of possibilities, using **square** or **cylindrical** housing structures, as well as direct or reversed coaxial arrangements to fit custom solutions

with either “**Moving Rod**” or “**Moving Cylinder**” application requirements.

Core improvement achieved by the **MICA™** technology is the suppression of any limited life wire electrical flying connection, which helps achieving **infinite fatigue life**. This is especially the case when used in combination with **frictionless flexure bearings** (Fig. 2.ak and Fig. 2.ag), instead of classical sliding friction bearings, or ball bearings. This featuring allows achieving on going nonstop operation over years without maintenance.

The enhanced force and compactness performance, given by the MICA™, is to the cost of decreased linearity of force versus position compared to moving coil ones, for long stroke applications, but nevertheless acceptable in most cases. This linearity decrease being also a featuring of high force/stroke moving coil actuators, other advantages of moving iron ones are considered as predominant especially considering the use of current shaping drive electronics, allowing linearisation and suppression of harmonic distortions, and reduced response time increasing moving mass acceleration capabilities.



Fig. 2.ag: MICA300CM

## 2.2.5. BISTABLE LINEAR MOVING MAGNETS ACTUATORS BLMM

**Bi-stable Linear Moving Magnets actuators BLMM** are based upon the reluctant force principle, achieved with a combination of permanent magnets, and electromagnets. Such an actuator topology allows achieving two stable positions at rest, maintained by the magnetic holding force provided by magnets, and without requiring any electrical power nor dissipating any heat. Commutation between the two positions is achieved by applying short electrical impulses, at fast speed, and short response time (Fig. 2.al).

The BLMM are composed of two fixed parts, realised with two back to back electro-magnets (Fig. 2.am), each combining coils and soft materials, and a moving part composed of a magnet assembly and a shaft structure.

Bi-stable actuators are perfectly suited for commutation mechanism, such as contactors, locking devices, and latch mechanisms (Fig. 2.an). Most common application of bi-stable actuators is for on/off latch electro-valves in fluid applications. The advantage of **bi-stable actuators**, realised with **BLMM** permanent magnets magnetic topology, is the high level of miniaturisation achievable (Fig. 2.ao), while keeping a fast commutation speed, and a high holding force at rest.



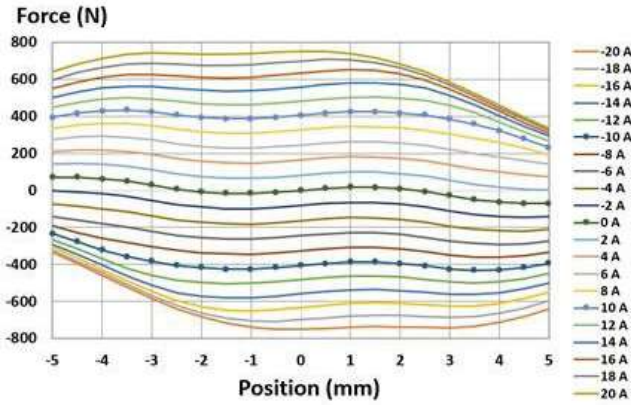

Fig. 2.ah: MICA™ linearity profile of force vs position

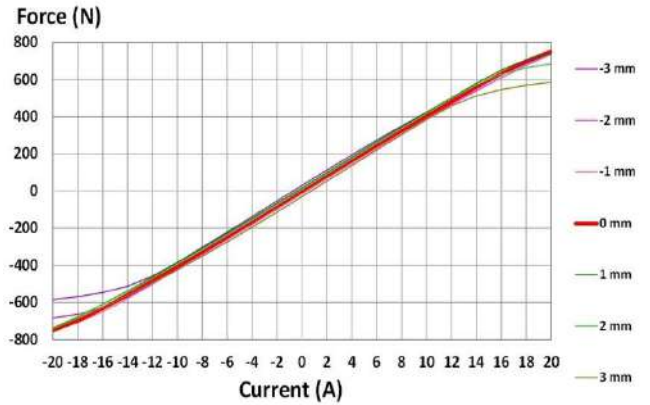

Fig. 2.ai: MICA™ linearity profile of force vs current

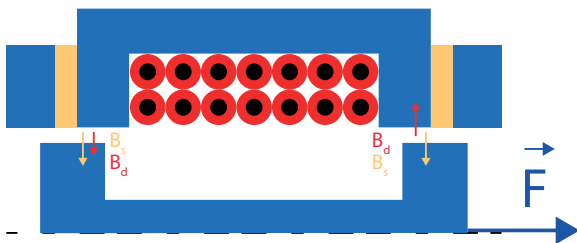

Fig. 2.aj: MICA magnetic principle



Fig. 2.ak: MICA20CS

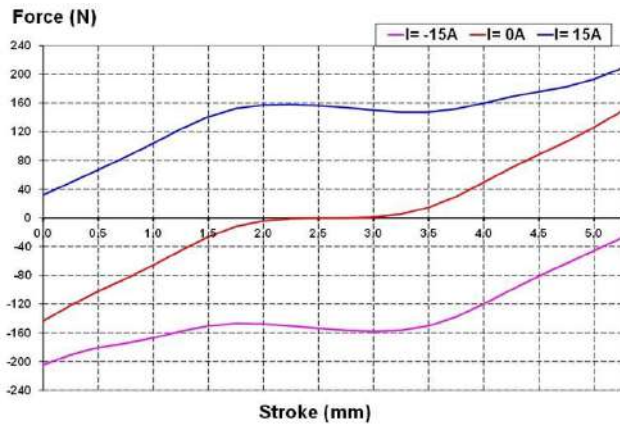

Fig. 2.al: Force vs Position

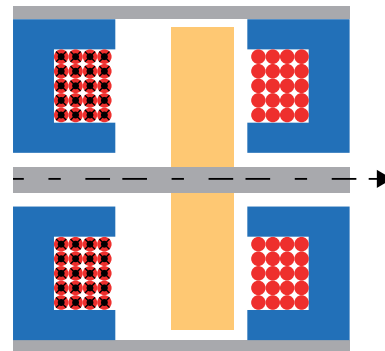

Fig. 2.am: BLMM magnetic principle



Fig. 2.an: Customised BLMM200M actuator offering 200 N locking force



Fig. 2.ao: CTEC miniature BLMM1XS actuators

## 2.2.6. LIMITED ANGLE TORQUE ACTUATORS LAT

**Limited Angle Torque LAT** are high resolution cog-free rotational actuators. They are the counter part of controllable linear magnetic actuators, achieved with same magnetic principles but in rotational configuration instead. Such actuators can be realised with both **reluctant** and **Laplace** force principles.

LAT actuators are composed of fixed parts called “**Stators**”, and moving parts in rotation called “**Rotors**”. They can be realised using either **moving iron**, **moving magnet**, or **moving coil** actuator topologies.

LAT actuators are single phase actuators, which are an alternative solution, compared to multiphase electric motors. The LAT actuator technologies take benefit of dedicated limited angle actuator designs, which makes them more relevant for angular position control applications, with enhanced performances compared to BLDC motors.

LAT technologies feature **perfect angular motions**, without any magnetic incremental stepping, limiting angular resolution, and generating vibrations. LAT actuators’ topologies are achieved instead with single phase coil assemblies, allowing true DC control, without any

electrical commutation electronic required, and with two ways motional directions according to current direction. This feature allows achieving both **closed loop feedback control**, as well as **open loop proportional control** using angular spring back flexural pivots.

Most recent actuator topology, achieving highest performances, is the **MICA™ LAT** technology, which is the counterpart of **Moving Iron Controllable Actuator** linear topology, in rotational configuration. This design option feature same advantages, with **fixed coils** and **fixed magnets**, allowing efficient thermal heat sinking by conduction, and without limited life wire electrical flying connection. As per the linear versions of **MICA™** actuator, theoretical **infinite fatigue life** is achieved, especially when used in combination with **friction less** bearings, instead of sliding friction or ball bearings. This featuring allows achieving on going nonstop operation at stabilized low coil temperatures, over years and without maintenance, even under vacuum or confined environments without air convection. Advantages of current shape electronic methods are also applicable to **MICA™ LAT** actuators, in order to linearise torque versus position, increase rotor acceleration capability, and to reduce response time.



Fig. 2.ap: Moving magnet LAT

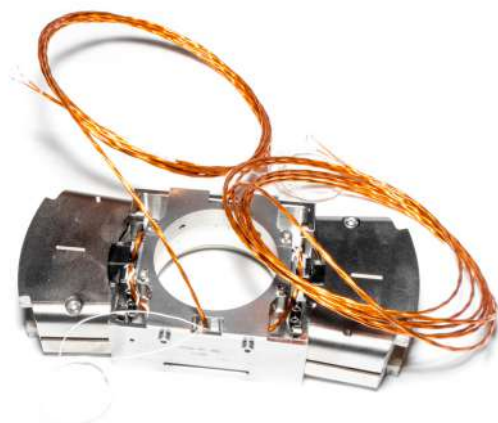

Fig. 2.aq: Moving coil LAT

### 2.2.7. CHOOSING VOLTAGE OR CURRENT ELECTRICAL DRIVING PRINCIPLES

The **drive electronic principle** for a given actuator application, has to be chosen not only according to electrical requirements of the actuator itself, but also according to the control logic. The existing drive electronic options are divided in two categories, i.e. **voltage control** electronics, or **current control** electronics.

**Voltage control electronics** provide optimised control to apply a given voltage at the actuator wire lead connection. The current delivered to the actuator coil is then the result of the actuator electrical impedance.

**Current control electronics** provide optimised control to apply a given current to the actuator wire lead connection. These are the most adapted drivers for magnetic controllable actuators as their force is proportional to the current. The voltage applied to the actuator coil is then the results of the actuator electrical impedance.

Both electronics categories have similar performances when used with linear actuators, and with sine wave

cyclical input commands shapes, but differs if not the case, due to the 90 degrees response lag between the two.

When used with the objective of increasing transient performances, such as enhanced **moving mass acceleration**, and **reduced response time** in actuator position control, current based drive electronics have far better performances. Indeed, this second category has the so called “**Current Shaping**” capability, which differs from output current control achieved by a **PID** type controller (**P**roportional **I**ntegral **D**erivative) driving a voltage based electronic. Linearisation of force versus current, as well as fast response time are achieved with far better performance with an electronic that control current, instead of voltage. Indeed the current based drive electronics have the capability to withstand output peak

voltage shapes not accessible by PID voltage control, which results in **enhanced actuator response time** in position control.



Fig. 2.ar: CTEC CSA96 : current based drive electronic

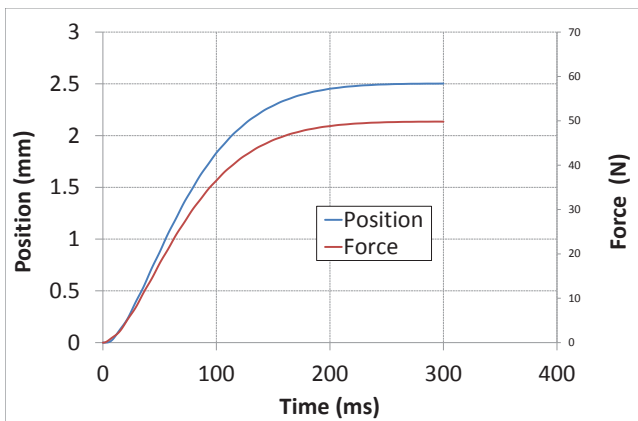

Fig. 2.as: Closed loop Voltage driver - Position

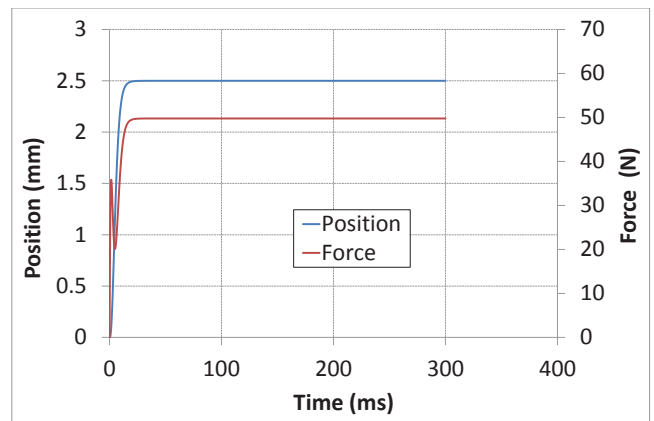

Fig. 2.at: Closed loop Current driver - Position

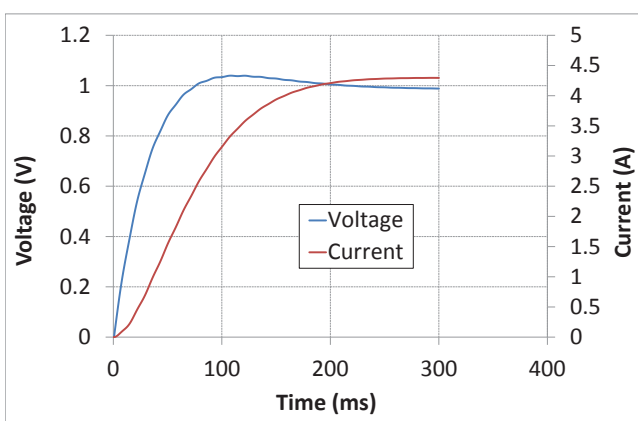

Fig. 2.au: Closed loop Voltage driver - Voltage

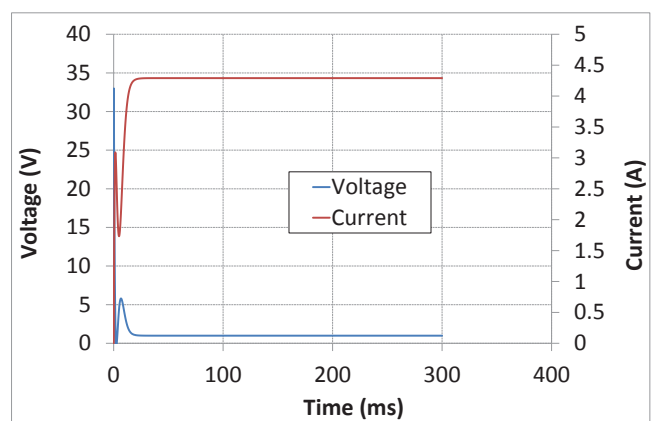

Fig. 2.av: Closed loop Current driver - Voltage

## 2.2.8. ELECTRICAL IMPEDANCE ADJUSTMENT

**Electrical impedance matching** of an actuator coil assembly, either standard or custom, allows adjusting the output performance of this actuator when used with a given drive electronic, or power source.

Drive electronics, and power source hardware, having limited output voltage and current capabilities, the force output of an actuator is not limited first by either its magnetic or mechanical designs, but instead by the input supply limitations in voltage and current. The tuning of the actuator electrical impedance defines its performance output to given current and voltage input supply, that defines its boundaries limits in force, acceleration, and heat dissipation, versus frequency. For that reason the drive electronic limits reduce the available output performances of a given actuator as follows:

- **Current limit:** limitation of force and acceleration
- **Voltage limit:** limitation of the frequency bandwidth

Adjusting the electrical impedance of an actuator consists either in:

- **Increasing the coil wire diameter** to increase the frequency bandwidth, but to the cost of a decrease in force and acceleration capabilities. (i.e. reduction of number of wire turns in same coil volume)
- **Reducing the coil wire diameter** to increase the force and low frequency acceleration capabilities, but to the cost of a frequency bandwidth decrease. (i.e. increase of number of wire turns in same coil volume)

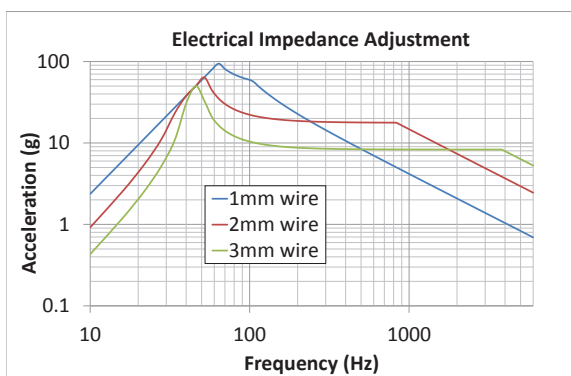

Fig. 2.aw: Impedance adjustment with wire section selection

## 2.2.9. RESONANT FLEXURE BEARING ACTUATORS

**Resonant flexure bearing actuators** are actuators having a specific mechanical design based on **frictionless bearing components** called “**Flexures**”, which consist in **planar springs** of thin thickness having infinite fatigue lifetime capability. Flexure bearing actuators can be realised with any magnetic topology, such as **moving coil, moving magnets, moving iron**, and **MICA™**. The flexures are anchored in the stator mechanical parts, and insure the moving mass motion guiding in both axial and radial directions, with no sliding friction, no lubricant, and no material wearing.

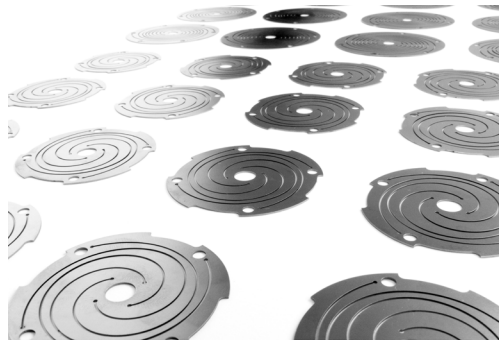

Fig. 2.ax: Flexure bearings

When a “fixed coil” actuator magnetic topology is chosen, such as **moving magnet, moving iron**, no coil wire flying lead connection is submitted to cyclical fatigue. Therefore when used in combination with flexure bearings, the complete actuator assembly achieves infinite fatigue lifetime capability. Flexure bearing

actuators are therefore best candidates for applications requiring **long lifetime without maintenance**.

The flexure bearing actuators have enhanced position control performances, and allows achieving ideal “**step and stay**” control precision and response time, thanks to the frictionless moving mass motion which is free of any stick slip parasitic effects as met in friction bearing actuators (Fig. 2.ay).

The use of flexure bearing actuators allows taking benefit of the **mechanical resonance** given by the association of the moving assembly mass and the stiffness of the flexures. This resonance can be used either to achieve inertial force higher than the magnetic force alone, for application such as vibration cancellation using proof mass actuators, or to achieve high efficiency for power application such as pumps and compressors.

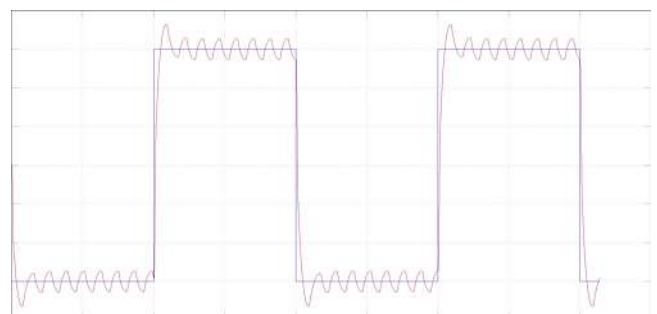

Fig. 2.ay: Stick-slip effect in step and stay position control of friction bearing actuator

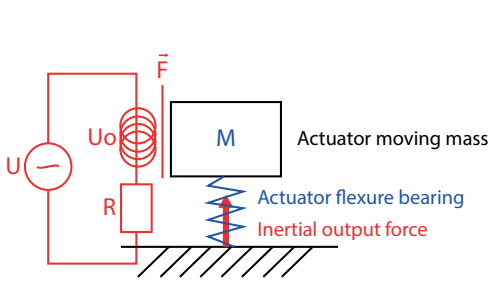

Fig. 2.az: Inertial force application (proof mass)

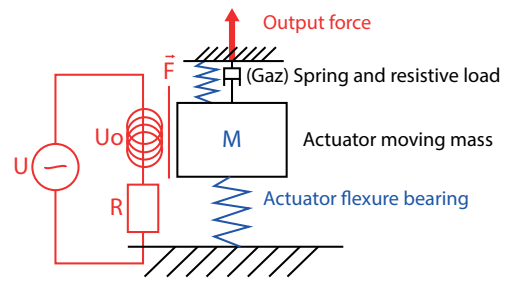

Fig. 2.ba: Power application (compressor)

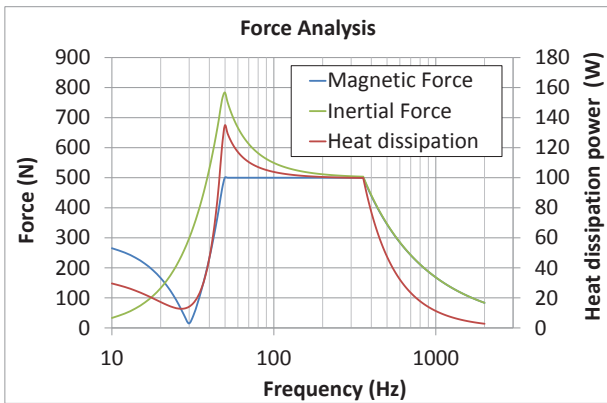

Fig. 2.bb: Inertial force application - Force analysis

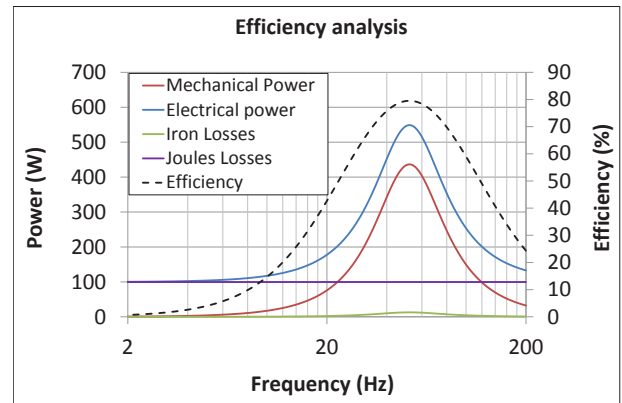

Fig. 2.bc: Power application - Efficiency analysis

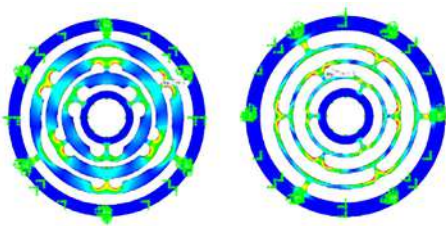

Fig. 2.bd: Non linear flexure bearings - Ortho-radial shape

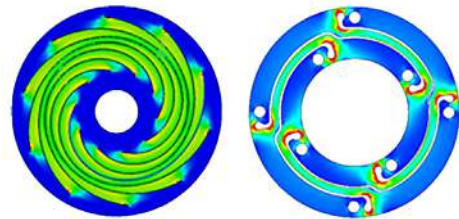

Fig. 2.be: Linear flexure bearings - Spiral and circular shapes

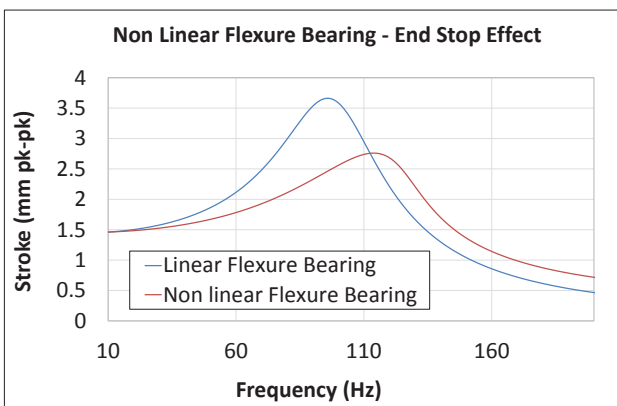

Fig. 2.bf: Stroke vs Frequency

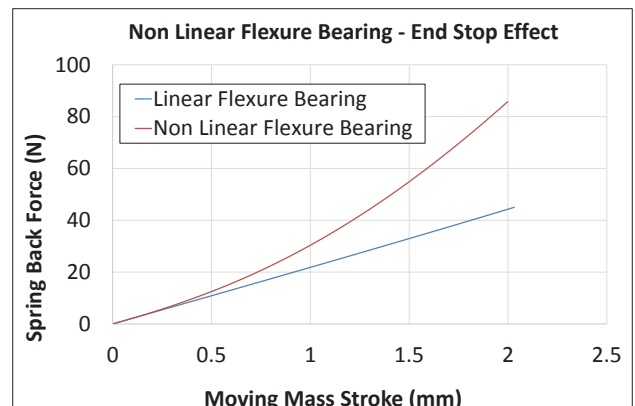

Fig. 2.bg: Spring back force vs Moving mass stroke

When choosing the **MICA™** magnetic topology, additional enhanced cleanliness properties are possible, thanks to both fixed coil and fixed magnets, which can be assembled over side from a leak tightened stator assembly. Therefore in high purity gases, and liquids applications, in domains such as medical, food, or cryogenics, which have biocompatibility or high cleanliness level requirements, the **MICA™** actuator topology warranties that only the moving assembly materials are in contact with the media. This feature allows achieving ultralow outgassing performances, thanks to the very simple moving iron mechanical design, having only metallic mechanical assemblies, free of bonding as well as plastic components and corrosion sensitive parts, which can generate contaminants over time in the media.

Flexure bearings of various designs are proposed by Cedrat Technologies (CTEC), according to stroke amplitudes and **linearity requirements**, as well as actuator housing shapes that could be either cylindrical, rectangular, or of any other one. Achieving infinite fatigue lifetime designs, with proper manufacturing processes, is a core knowhow that has to be developed and demonstrated over years with experimental statistical results on product series, as well as lifetime cyclical fatigue tests.

When considering the resonant effect two categories of flexures can be proposed, according to the requirements of the application:

- When the resonance is intended as **performances enhancement**, for vibration cancellation proof mass applications or for power efficiency applications such as compressors and pumps, high linearity is required, and **linear spiral & circular flexure types** are best suited and proposed by CTEC.
- When the resonance is potentially a **parasitic effect**, for applications such as enhanced frictionless step and stay position control, **nonlinear orthoradial “end stop effect” flexure types** are proposed by CTEC, which provide nonlinear stiffness that suppresses the magnitude factor at resonance, by frequency de-tuning.

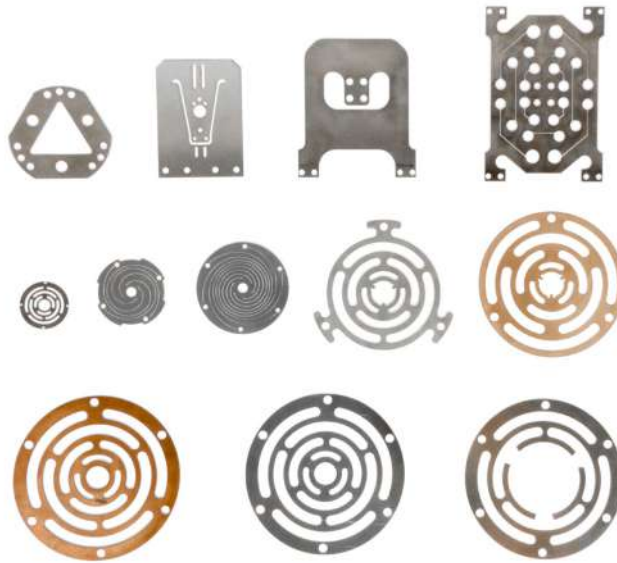

Fig. 2.bh: Flexure bearings

In order to achieve reliable flexure bearing actuators manufacturing, with appropriate long lifetime fatigue performances, special care has to be given to the manufacturing of the bearings, which are affected by the scattering of the machining processes. For that reason, process qualification is required, and controlled batch manufacturing approach is required for large quantities, which is a key knowhow of CTEC.



Fig. 2.bi: MICA300CM



Fig. 2.bj: MICA200M



Fig. 2.bk: MICA20CS

### 2.2.10. ELECTROMECHANICAL LIMITS OF ACTUATORS

**Electromechanical limits of actuators** have to be calculated to estimate the performance for given **application requirements**, and according to the selected **drive electronics**. In order to achieve such calculation CTEC has developed in house **COMMACT™ software** (Computation of Magnetic Actuators) that performs complex actuator analysis, based on the connected application stiffness, work load, and mass, and taking into account actuators' magnetic designs, losses, electrical impedances, as well as the drive electronics output current and voltage limits.

A magnetic actuator, in dynamic operation, can be modelled by a generic Laplace law, which makes use of the force constant (magnetic force to current ratio)  $FK$ , as follows:

$$U(t) - FK \dot{x}(t) = R_0 I(t) + L_0 \dot{I}(t)$$

With:

- $U(t)$  = Voltage
- $I(t)$  = Current
- $R_0$  = Coil resistance
- $L_0$  = Coil inductance
- $FK$  = Magnetic force to current ratio
- $\dot{X}$  = moving mass speed

By combining this equation with the dynamic mechanical one, of the moving mass mechanism, by taking in consideration the flexure bearing stiffness, and Iron loss coefficient, one can derive the coupled electro-mechanical equation in order to calculate the different electrical and mechanical parameters behavior.

$$FK \dot{I}(t) - F(t) = m \ddot{x}(t) + \theta \dot{x}(t) + k x(t)$$

With:

- $FK I(t)$  = Magnetic force produced onto the moving mass
- $F(t)$  = External force applied onto the moving mass
- $m$  = Moving mass
- $\theta$  = Iron loss equivalent damping
- $k$  = Stiffness of the flexure bearings

In the frequency domain the coupled equations results in the following electrical scheme, which is composed of an electrical impedance, and a motional one which traduces the back electromotive force of the actuator:

$$U(\omega) = [Z_{Electrical} + Z_{Motional}]I(\omega)$$

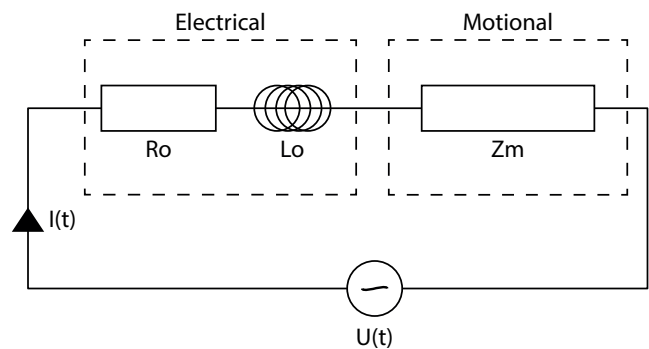

Fig. 2.bl: Equivalent electrical scheme of magnetic actuator

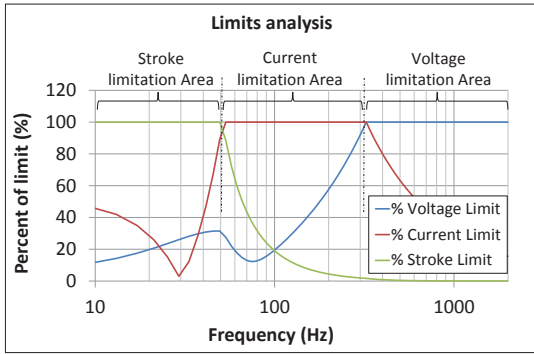

Fig. 2.bm: Limits analysis

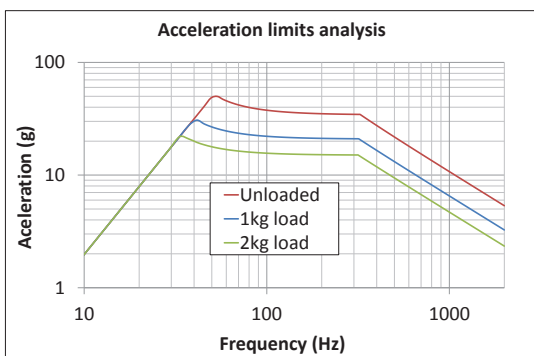

Fig. 2.bn: Acceleration limits analysis

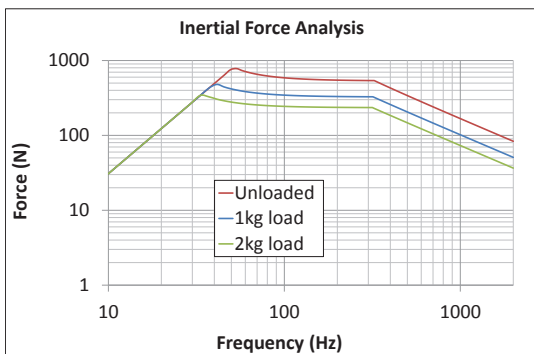

Fig. 2.bo: Inertial force analysis

Such modelling approach allows to calculate for given combinations of actuator, drive electronic, and application load, the frequency domain limits which mainly consist in:

- Actuator stroke limit (low frequency range)
- Drive electronic output current limit (medium frequency range)
- Drive electronic output voltage limit (high frequency range)

Given the frequency domains limits can be calculated the actuator different performances such as maximum acceleration and inertial forces versus frequency.

### 2.2.11. ACTIVE & REACTIVE ELECTRICAL POWER

**Power applications** require the use of an actuator operated in order **to generate or absorb mechanical power**. For that, the actuator moving mass is put in motion by the magnetic force, in front of a mechanical resistance that absorb or dissipate mechanical power. Such an actuator operation is typically required for linear thermal machines such as compressors, pumps, pressure wave generators, and for linear energy recovery machines such as linear alternators, and gas expanders.

Such an operation of an actuator is characterized by the requirement of producing a force against a mechanical device that will absorb, or dissipate, the mechanical power by means of a phase lag between the actuator moving mass velocity, and output force, lower than 90°. Therefore, in that specific case, the electrical power absorbed by the actuator is used to compensate the output mechanical power and the actuator losses, i.e. Joules and iron losses, which are dissipated into heat. The efficiency of the actuator and associated heat dissipation, during this operation are then defined as follows:

$$Actuator\ Efficiency = \frac{Output\ Mechanical\ Power}{Input\ Electrical\ Active\ Power}$$

$$Actuator\ Heat\ Dissipation = (1 - Efficiency) \cdot Input\ Electrical\ Power$$

In most application the output mechanical power provided by an actuator, connected to a given application, can be analysed with a viscous damper work load analogy.

Considering the phase lag between the damper force  $\vec{F}$  and velocity  $\vec{V}$   $\varphi=0^\circ$  to achieve the maximum power, the output mechanical power integration of the actuator over a period is positive.

$$\int_0^T \vec{F} \vec{V} = \frac{1}{2} \|\vec{F}\| \|\vec{V}\| \cos \varphi = \frac{1}{2} R_L V^2$$

with  $R_L = resistive\ load$

The limit analysis performed with **COMMACT™ software** allows providing the actuator force limits, electrical power, efficiency, and heat dissipation.

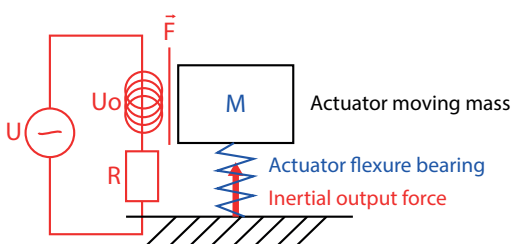

Fig. 2.bp: Inertial force application (proof mass)



The analysis of power factor allows to estimate the global efficiency the combination of Actuators plus Drive Electronics, by calculation of the so called “**Active Power**” and “**Reactive Power**”.

- The **active power** is the electrical power **absorbed by the actuator**, which shall be converted into output mechanical power for the application, and heat dissipation accordingly to the actuator efficiency. The active power is defined by the power factor  $\cos(\varphi)$  with  $\varphi$  being the phase lag between the actuator input voltage and current.

$$\text{Actuator Active Input Power} = V_{rms} \cdot I_{rms} \cdot \cos \varphi$$

- The **reactive power** is the electrical power **stored by the actuator**, toward the drive electronic, which shall be converted into heat by the drive electronic itself if not featured with energy recovery capability. The reactive power is defined by the counterpart of power factor  $\sin(\varphi)$  with  $\varphi$  being the phase lag between the actuator input voltage and current.

$$\text{Actuator Reactive Input Power} = V_{rms} \cdot I_{rms} \cdot \sin \varphi$$

If a drive electronic without reactive power recovery capability is chosen for high power application, the combination of electronic plus actuator should be used as close as possible to the resonance frequency, where the actuator power factor is the highest close to  $\cos(\varphi)=1$ , otherwise very significant heat dissipation shall have to be handled by the drive electronic using *fans* or *refrigerant cooling loops*. The drive electronic efficiency is therefore highly affected by the actuator power factor:

$$\text{Drive Electronic Efficiency} = \frac{\text{Actuator Input Active Power}}{\text{Drive Electronic Input Electrical Power}}$$

$$\text{Drive Electronic Heat Dissipation} = (1 - \text{Efficiency}) \cdot \text{Input Electrical Power}$$

With the objective of providing high efficiency combinations of actuator and drive electronic, CTEC has developed drive electronics (such as CSA96) with reactive power recovery feature which allows achieving electronics efficiencies higher than 90%.

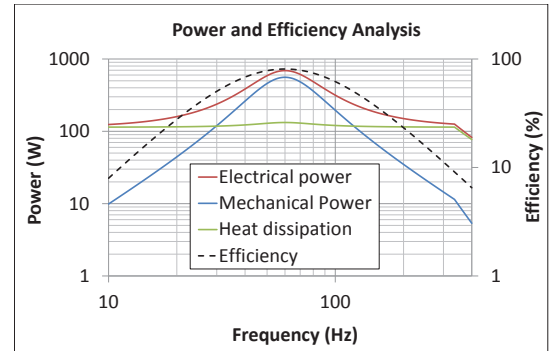

Fig. 2.bq: Power and efficiency analysis

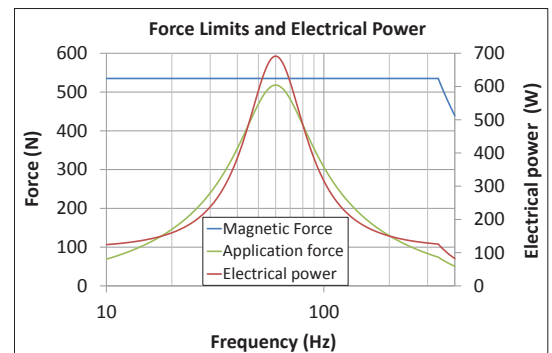

Fig. 2.br: Force limits and electrical power

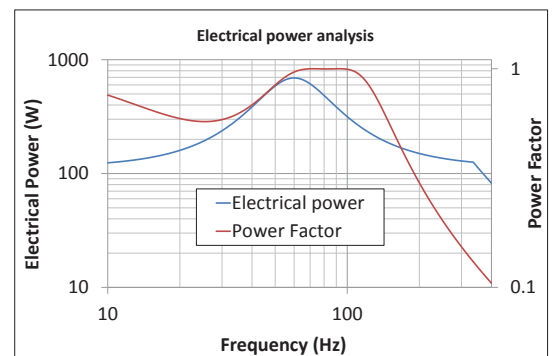

Fig. 2.bs: Electrical power analysis



Fig. 2.bt: CSA96-IS

## 2.2.12. MAGNETIC ACTUATORS HEAT DISSIPATION

**Heat dissipation analysis** is a key result that need to be taken into account for the operability of a given actuator over time. This result can be obtained for whatever application case, and actuator technology by the use of the in house Cedrat Technologies (CTEC) **COMMACT™ software**.

This information gives a quantitative value of a heat dissipation power, but then has to be analyzed in terms of **heat sinking** capability, to estimate the temperature increase and stability over time of a given actuator. Two categories of actuators' technologies have to be considered:

**Moving Coil Actuators**, which have flying coil, have **no coil heat sinking capability**, and the coil can only be cooled by Air convection within the sharp and confined magnetic field gap of the actuator, where the coil is moving. Therefore for such an actuator, the maximum coil temperature (~150°C to 200°C) is achieved very quickly, and the actuator output force has to be reduced in order to operate at a coil temperature not exceeding this value. For a given environmental Air convection condition, natural, or forced, this maximum force value is sometime called "**Nominal Force**", "**Continuous force**" or "**Stall Force**". As the Air convection cooling capacity is highly linked to the application confinement, this nominal force value differs for each case, is not easily predictable, and is the **major limitation of the moving coil technology**, reducing very significantly the allowable force for continuous operation, compared the maximum force called "**Peak Force**", only available during very short term operation. As the operational temperature of moving coils is high, the efficiency losses by increase of Joules effect is a significant consequence, due to wire resistivity increase at high temperature.

**Fixed Coil Actuators**, which includes **Moving Magnets, Moving Iron,** and **MICA™** actuators have **far much better heat sinking capabilities** compared to moving coil ones. A fixed coil wound over a mechanical structure have heat sinking capability by conduction, which is not possible with a flying coil. This heat sinking by conduction allows achieving remote coil cooling by either passive natural air convection, using external fins on the actuator structure, or active cooling using external refrigerant cooling loops or forced air convection. When considering passive natural convection, fixed coil actuators can have **significantly greater "continuous force"** capability compared to moving coil actuators, and **much longer heating time** toward classical allowed 150°C coil temperature, as well as much faster temperature **decrease at rest**. When considering actively cooled long term continuous operation, fixed coil actuators can operate at **stabilised low coil temperature**, which is much more favorable from Joules effect point of view and efficiency, whereas such equivalent low temperature continuous operation is not possible with moving coil actuator for the same mechanical load.

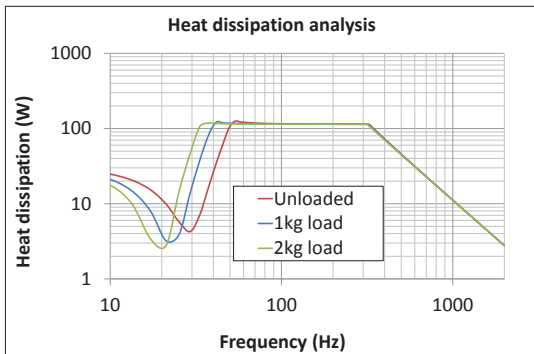

Fig. 2.bu: Commaact™ - Vibration assistance application

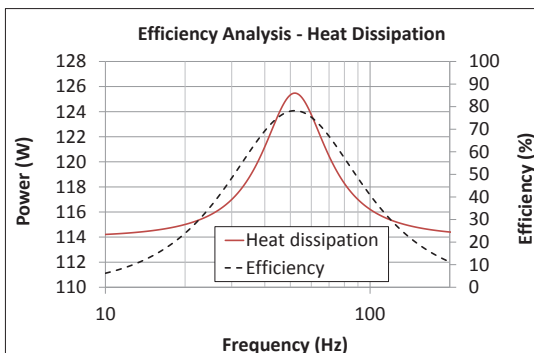

Fig. 2.bv: Commaact™ - High efficiency power application

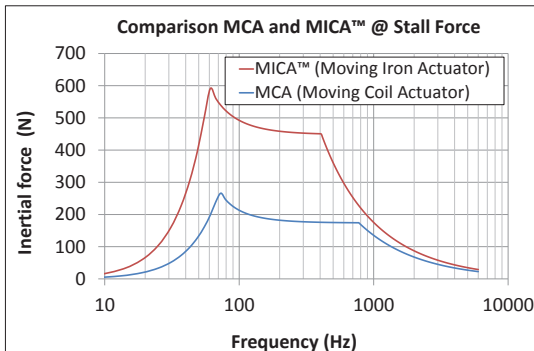

Fig. 2.bw: Comparison of same size MCA and MICA™ at nominal force

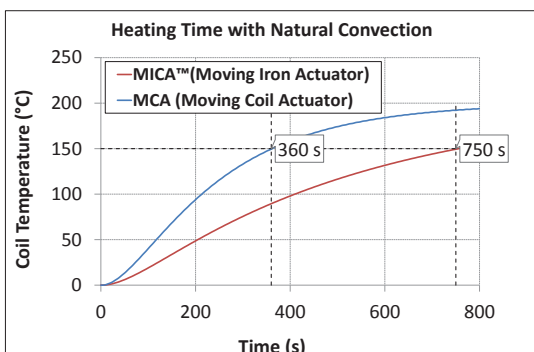

Fig. 2.bx: Comparison of same size MCA and MICA™: Heating time with natural convection

### 2.2.13. ANALYSIS OF MAGNETIC ACTUATORS WITH LOSSES

**Analysis of magnetic actuators with Losses** is a key analysis which can be performed using the CTEC in house **COMMACT™ software**. This analysis allows estimating true actuator performances, taking in account the different sources of loss that will be converted into heat, and which will reduce the actuator targeted performances:

- Joules losses
- Mechanical viscous and solid frictions losses
- Actuator Iron losses
- Application nonlinear effects (as friction)

**Mechanical losses** reduce the **magnification factor** of a given actuators moving mass, which means that a higher forces are required to achieve the targeted stroke and acceleration.

**Iron losses** are magnetic losses that include **Eddy currents** and **Hysteresis losses**, which reduce both the moving mass magnification factor, and the actuator **frequency bandwidth**.

**Application non linear effects**, such as **friction**, **non linear stiffness** and **non linear work load**, are non direct losses because they do not result directly in a conversion of input power into heat dissipation. Such effects induce indirect losses because they induce a decrease of mechanical power factor, and electrical one, as well as a magnification factor decrease by frequency de-tuning. The actuator acts again a “**virtual end stop stiffness**” that requires higher force to achieve the targeted displacement. The decrease of electrical power factor induces an additional electrical loss due to a **significant actuator reactive power**, that is converted into heat by Joules effect if the drive electronic does not feature energy recovery capability.

Cumulating all losses can result in a significant decrease of performance compared to expected, if not taken in account. In custom designs for power efficiency application such as thermal machines, pumps, and compressors, all losses are to be reduced as much as possible by design, using **frictionless flexure bearings**, as well as soft material assemblies composed of optimised **finned**, **slotted**, **sintered**, or **laminated** mechanical parts.

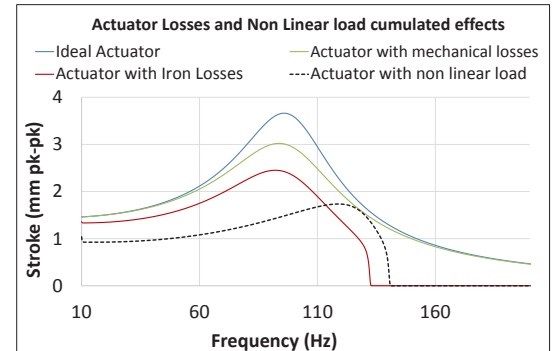

Fig. 2.by: Stroke vs frequency

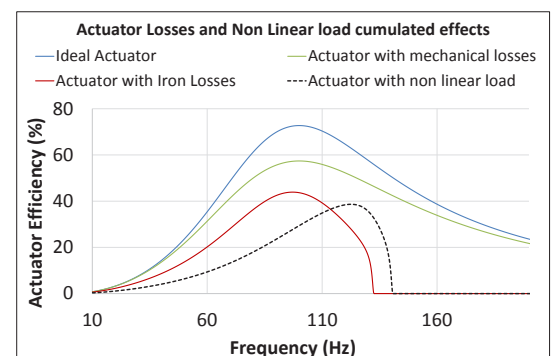

Fig. 2.bz: Efficiency vs frequency

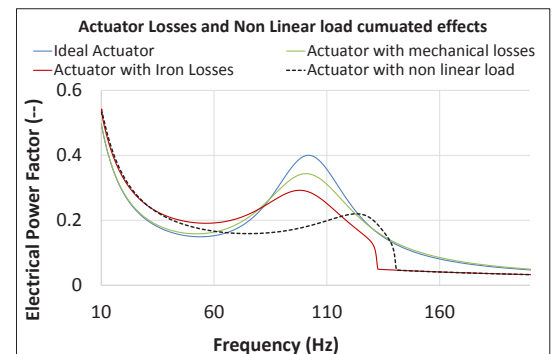
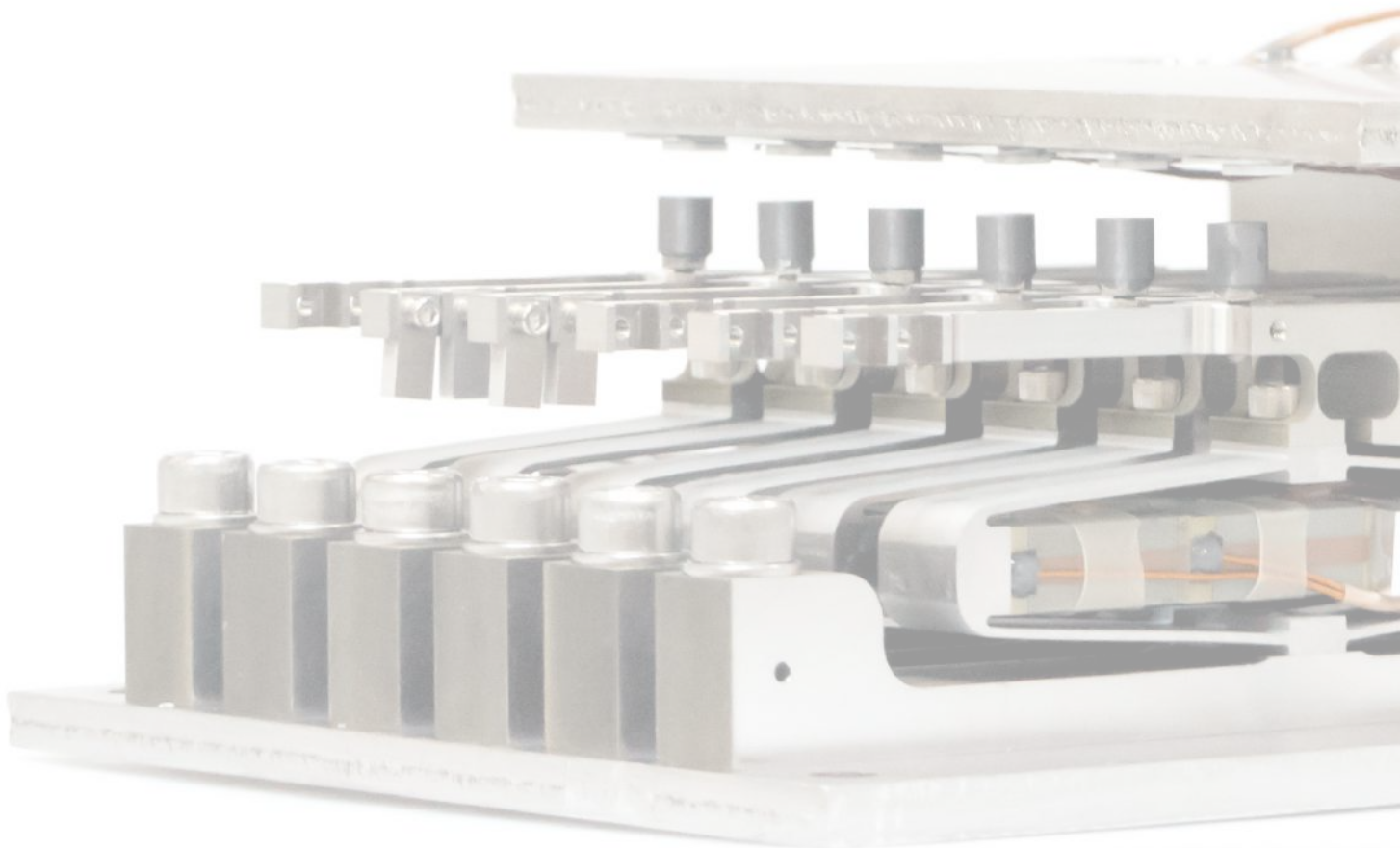

Fig. 2.ca: Electrical power factor vs frequency



**For more information on this chapter,  
please visit these pages:**

[cedrat-tec.com/applications](http://cedrat-tec.com/applications)

[cedrat-tec.com/technologies](http://cedrat-tec.com/technologies)

## 3. MARKETS & APPLICATIONS

### 3.1. MARKET OVERVIEW

Products and developments provided by CEDRAT TECHNOLOGIES (CTEC) find applications in all the fields of mechatronics. The major ones are **air & space**, **optronics**, **scientific instrumentation**, **production and manufacturing** and **medical technology**.

All these application fields gather round advanced functions requiring fast or precise actuation: precise positioning, fast displacement, vibration/force generator, vibration damping. Some related applications and their working conditions are given in section 3.2, page 45.

CTEC, as a customer-oriented company, manufactures and sells not only standard products, but also customised solutions, especially for OEM (Original Equipment Manufacturer) series.

The range of standard actuators from CTEC is a first commercial off the shelves (COTS) solution for satisfying a wide spectrum of technical specifications & environmental conditions in short time delivery. Some of the products presented in this catalogue are in “preliminary data” as noted in their performance table. It means those products are not available off the shelves and may require some extra engineering work to be so. To satisfy some demanding customer requirements met in OEM business, CTEC can optimise, adjust and extend the performances of its actuator technologies. The aim is to be compliant with technical, environmental, economical or other specifications that are necessary to provide the customer with the best value added on its system integration. Several situations may arise:

- Some performances like stroke or force of standard actuators have to be increased,
- The mechanical interfaces have to be adjusted to make the final integration easier,
- The application requests a more complex mechanism than a single actuator,
- A special feature such as non-magnetism or harsh environment compatibility is required.

Solutions to remove these limitations are shown through applications in section 3.2, page 45 and are completed with additional technological solutions introduced in section 3.3, page 54.

In all these cases, CTEC can provide all the services presented in section 1.4, page 12 to help the customer with a fast solution combining its existing products, its building blocks, its experience and its development facilities.



## INSTRUMENTATION

- Telescope mirror motorisation
- Synchrotron fast shutters
- Environmental & material testing
- Beam shaping



## OPTRONICS

- Micro-scanning & pixel shifting
- Optical image stabilisation
- Autofocus
- Embedded mechatronic functions

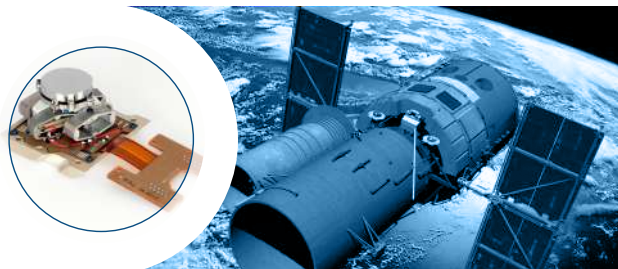

## AIR & SPACE

- Optical mechanisms flight hardware
- Scan mechanisms for earth observation
- Hold-down release mechanisms ( HDRM)
- Fast steering mirrors



## MEDTEC

- Micro actuation
- Miniaturised motorisation
- Microfluidic control device

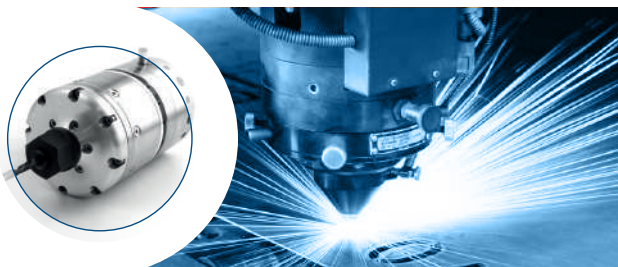

## MANUFACTURING

- Chatter cancellation
- Vibration assistance for machining
- Active clamping fixtures

### 3.2. APPLICATIONS & FUNCTIONS CLASSIFIED BY WORKING CONDITIONS

The working conditions are the kinematic conditions so that the inertia and dynamic force impacts on the actuator are taken into account. The working conditions are split into several kinematic conditions: static, dynamic non resonant, resonant...

The function is the type of physical action or operation (force, motion, vibration,...) that the actuator generates on the user's system. The function is the answer to the following question: How is the actuator used inside the system?

The application is the result of the actuator's function inside the system. The application is the answer to the question: What is the actuator's operation/function used for?

The working conditions can be more or less demanding for the actuator and the electronics. They are associated to different frequency regions, introduced in previous section. Most of CEDRAT TECHNOLOGIES (CTEC) actuators can operate under dynamic conditions, which opens them to a wide range of applications and markets. To select an actuator for a given application, it is useful to know its function and working conditions (see Table 3.a).

WORKING CONDITIONS	INERTIAL FORCES	ELECTRIC POWER	FUNCTIONS / USED AS	APPLICATIONS / USED FOR
Static	Negligible	Negligible	<ul style="list-style-type: none"> <li>• Micropositioner</li> <li>• Slow actuator</li> <li>• Force Generator</li> </ul>	<ul style="list-style-type: none"> <li>• Micro &amp; Nano positioning</li> <li>• Flow control</li> <li>• Material Stress testing</li> </ul>
Dynamic Strain non resonant	Not negligible	Can be very high and may be the limiting factor	<ul style="list-style-type: none"> <li>• Wide bandwidth</li> <li>• Vibration generator</li> <li>• Vibration damper</li> <li>• Fast actuator</li> </ul>	<ul style="list-style-type: none"> <li>• High frequency Shaker</li> <li>• Forced Vibration Assistance</li> <li>• Active damping, Isolation</li> <li>• Shutter, XY Scanning</li> <li>• Fast positioning</li> <li>• Material stress cycling</li> </ul>
Dynamic Strain at resonance	High	Not negligible (Applied voltage should be monitored)	<ul style="list-style-type: none"> <li>• High-amplitude</li> <li>• Vibration generator</li> <li>• Sonic transducer</li> <li>• Ultrasonic transducers</li> </ul>	<ul style="list-style-type: none"> <li>• Resonance Vibration</li> <li>• Assistance to process</li> <li>• Ultrasonic welding, micro-injection moulding ...</li> <li>• Fluid degassing, cleaning</li> </ul>
Dynamic force	High	High	<ul style="list-style-type: none"> <li>• Proof-mass vibration / force generator</li> <li>• Proof-mass vibration damper</li> </ul>	<ul style="list-style-type: none"> <li>• SHM structure exciters</li> <li>• Hammer</li> <li>• Active damping of structures</li> </ul>
Impulse Strain (Dynamic)	Can be high	Can be very high and may be the limiting factor	<ul style="list-style-type: none"> <li>• On-off fast actuators</li> <li>• Impactors</li> <li>• Long-stroke actuation (SPA Motors)</li> </ul>	<ul style="list-style-type: none"> <li>• Shutter</li> <li>• Fluid injection</li> <li>• Circuit breaker</li> <li>• Fast positioning</li> <li>• Long-stroke positioning</li> </ul>
Dynamic Sensing	Can be high (due to external vibrations)	Negligible (Generated voltage should be monitored)	<ul style="list-style-type: none"> <li>• Electric generator</li> <li>• Force sensor</li> </ul>	<ul style="list-style-type: none"> <li>• Energy Harvesting</li> <li>• Igniters</li> <li>• Force Sensing</li> </ul>

Table 3.a Applications, functions & working conditions

### 3.2.1. APPLICATIONS OPERATED UNDER STATIC CONDITIONS

#### TILT MECHANISMS

As Amplified Piezoelectric Actuators (APA®) are rather flat, they can be arranged in parallel. It is interesting either to increase the force or for tilting applications (Fig. 3.a). In this last case the flat structure of APA® allows to place their actuation axes close together to get a relatively large tilt angle. This is shown with a first tilt mechanism TT50S based on two APA50S actuators and producing an angular displacement of +/- 0.5° and a resonance frequency of 1800 Hz. In this mechanism, the Finite Element Method can be used to design flexural hinges (Fig. 3.b).

Using this possibility, standard tilt or double tilt mechanisms products have been designed for optical deflection: TT60SM and DTT35XS (see 5, page 77), respectively based on two APA60SM and four APA35XS mounted with flexural hinges .

Customised tilt mechanisms can also be easily derived from other standard actuators. For instance, a space version of the DTT60SM has been developed for Airbus DS within the ATLID project (see Fig. 3.c). This mechanism has to withstand external vibrations and benefits from the APA® properties.

Another configuration to build tilts mechanisms has been designed for actuation functions in Micro Aerial Vehicles for ETZH (see Fig. 3.d). The complete mechanism is monolithic and uses two APA® in a push-pull configuration. This allows deflection of up to 10°, with a weight of only 0.35 gr.

#### XY & XYZ MICRO POSITIONING MECHANISMS

Several XY or XYZ stages have been designed at CEDRAT TECHNOLOGIES (CTEC) for various needs.

The customised XYZ smart mechanism for the MIDAS instrument of ROSETTA space mission was developed under an ESA/ESTEC contract, starting from standard APA50S and PPA10M. The function of this mechanism is

to ensure the nano-resolution scanning motion of an Atomic Force Microscope (AFM) under a severe environment (see Fig. 3.e). Although operated under static conditions, the ability of CTEC actuators to withstand large vibrations thanks to their pre-stress allowed the mechanism to pass vibration tests. It was launched in 2004 and run in 2014 when Rosetta reaches Churyumov-Gerasimenko comete.

Another example of XYZ mechanism developed for an optical application is given with Fig. 3.f. This mechanism is able to perform any stroke in the volume [-100,+100 µm] × [-100,+100 µm] × [0.200 µm]. It is entirely based on standard components. It combines a standard XY200M stage based on 4 APA200M for centred XY displacements (scanning function) with a set of 3 APA200M for Z displacements (focussing function).



Fig. 3.a: DTT batch

#### TRIPODS & HEXAPODS

CTEC's actuators have also been used to build complex nano-positioning mechanisms such as tripods, hexapods or 5 d-o-f mechanisms in the fields of astronomy and space optics. For example, CSEM (Switzerland)

and SENER (Spain) had to develop a tripod mechanism for nano-positioning and stabilisation of the M5 mirror in the Extremely Large Telescop (ELT) of ESO. The mirror mass is more than 600 kg. Therefore this induces a static load but also dynamic loads (due to possible earthquakes) have to be added to the functional dynamic load. After a trade-off analysis, CSEM and SENER have selected the APA® technology. CTEC has then developed 3 customised extremely-large actuators APA500XXL meeting these severe requirements (see Fig. 3.g).

Other examples of piezo actuators applications in mechanisms are given in:

[cedrat-tec.com/technologies/actuators/piezo-mechanisms](http://cedrat-tec.com/technologies/actuators/piezo-mechanisms)



## ELECTROMAGNETS FOR FORCE GENERATION

Customised electromagnets are developed by CTEC to generate the maximum of force / torque in the minimum of volume / mass. Such a feature is deemed essential for aerospace applications and these solenoids remain usual for static operation.

Within a volume of 10 cm<sup>3</sup> and less than 90 grams, rotary electromagnets are capable of providing up to 10 degrees angle with a torque higher than 160N.mm. Such a design complies with ECSS standard and this technology is delivered as flight models for Orion-ESM mission.

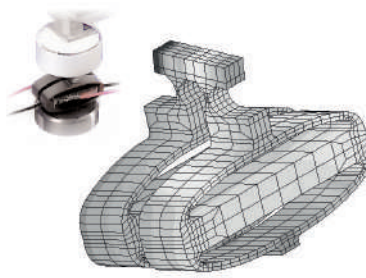

Fig. 3.b: Tilt-Translator TT50S (based on 2 APA50S actuators) and producing an angular displacement of +/- 0.5° and a resonance frequency of 1800 Hz.

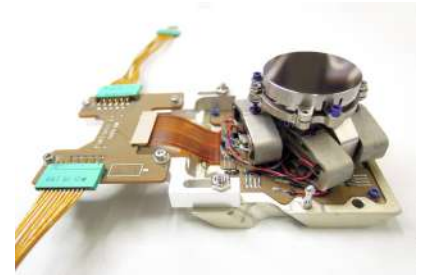

Fig. 3.c: DTT60SM based on 4 APA60SM-SG (courtesy of Airbus DS Sodern)

## ROTARY VOICE COIL MOTORS (RVCM)

Dedicated high performance voice coil motors are designed using multi-physics simulations skills, high performances material knowledge and system integration and qualification know-how.

RVCM is developed to equip the SCan Assembly (SCA) of Meteosat Third Generation (MTG) satellites. 20 years of operational lifetime are required for this application. Typical stroke achieves +/-15 degrees angle with a nominal torque of 0.4 N.m. Beyond its ability to withstand environmental requirements (thermal, vacuum, vibration 30 Grms, shocks...), this motor demonstrates high stability of the torque constant according to both position and current. Its unique balanced design allows to reduce parasitic forces and eases the integration of guiding system.



Fig. 3.d: Miniature Tilt-Translator TT40uXS (courtesy of ETHZ)



Fig. 3.e: Midas Space Instrument (courtesy of ESA)



Fig. 3.f: XYZ200M-SG stage for IR Spectroscopy (courtesy of GES Lab / Montpellier University)



Fig. 3.g: APA500XXL for ELT M5 mechanism (courtesy of CSEM, NTE and ESO)

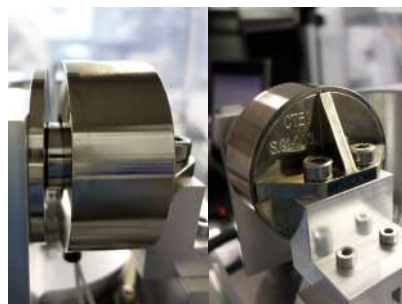

Fig. 3.h: Brake solenoid flight model



Fig. 3.i: RVCM flight model

## 3.2.2. APPLICATIONS OPERATED UNDER DYNAMIC NON-RESONANT CONDITIONS

### FAST XY STAGES FOR SCANNING, STABILISATION...

Several OEM XY stages for fast micro-scanning and stabilisation are produced in series by CEDRAT TECHNOLOGIES (CTEC).

XY25XS stage (Fig. 3.j) uses parallel piezo actuation, which is also used in XY200M products. This configuration is optimal for fast motion and renders feasible new optical functions. For example fast micro-scanning is highly beneficial in defence infrared cameras to improve the camera resolution. In this application the short response time of the actuators is used to perform a complex pattern to allow image reconstruction from several pictures at a rate of 100 Hz. Therefore the actuators are used under almost impulse strain conditions. In addition, the XY stage should operate in spite of external vibrations, the camera being embedded in land, aerial and sea vehicles. Therefore CTEC actuators' performances in dynamics are suited to this class of application.

Parallel magnetic actuation is another option when even larger strokes are needed. Fig. 3.k is a XY stage based on small Moving Iron Controllable Actuators (MICA™) offering 2 mm × 2 mm stroke, designed for optical stabilisation.

### SERVO PIEZO TOOLS

The Servo Piezo Tools (SPT) developed by CTEC can realise both fast and precise machining: applications vary from oval piston machining to aspherical lens machining.

For example, the SPT400MML (Fig. 3.l) prototype uses the Amplified Piezoelectric Actuator (APA®) APA400MML to obtain a large and fast motion of the diamond tool (400µm at more than 100Hz). The SPT400MML is arranged in a casing and dry air is used to expel dust from the casing. It includes an Eddy Current proximity Sensor for position control.

### ACTIVE VIBRATION DAMPERS

When coupled to well suited driving and control electronics, piezo actuators are excellent deemed candidates to actively damp the vibrations on a mechanical structure. CTEC has already developed and set up several OEM solutions based on APA® & Parallel Pre-stressed Actuators (PPA) for Active Control of Vibrations (ACV) on machine tools (see Fig. 3.m), ski and medical robot (see also Fig. 3.n).

### ACTIVE FIXTURE USING MICA200M

A technological breakthrough has been achieved with a new version of the MICA™. The MICA200M actuator and its dedicated compact power electronics has been developed in the frame of the INTEFIX FP7 project to address the field of active fixture (Fig. 3.o). That application is challenging since the MICA™ actuator's response is used for both vibration and deformation control during the machining of low rigidity parts. Therefore a better controllability of the actuator is needed in terms of force along the stroke, and on a wider range of frequency including static control.

Actuators or systems for vibrations damping are also available upon request. Other examples of applications of active damping are given in:

[cedrat-tec.com/technologies/mechatronic-systems/vibration-control](http://cedrat-tec.com/technologies/mechatronic-systems/vibration-control)

### VIBRATION GENERATOR OPERATING IN FORCED VIBRATION MODE

Amplified Piezoelectric Actuators (APA®) and Parallel Prestress Actuators (PPA) find several applications for vibration generation in forced vibration mode (below resonance): APA® and PPA used in forced vibration mode are typically used in machines for material mechanical testing, such as the lifetime test of Semicon silicon parts or films by stress cycling, or machines for vibration testing such as piezoelectric shakers (see Fig. 3.p).

Moving Iron Controllable Actuators (MICA™) are a new alternative for vibration testing. It offers more stroke (up to 10mm) compared to electrodynamic shakers while being much more compact.

Another range of industrial applications of this mode is the vibration assistance to processes. Forced vibrations provide a useful assistance in many processes such as food cutting, glass cutting, engraving, machining (milling, drilling...), extruding etc... Typically vibration assistance improves the process speed and/or surface quality.

An example in the field of Vibration Assisted Machining (VAM) or Modulation Assisted Machining (MAM) results from the AVIBUS project coordinated by CTEC. From tests of Arts et Métiers ParisTech (ARTS) and CETIM, the Vibration Assisted Drilling (VAD) tool holder of Fig. 3.q allows to reduce the drilling time by a factor of 3.

## POWERFUL VIBRATIONS GENERATION

CTEC has enhanced standard piezo actuators in order to address continuous high energy vibration generation. Firstly the preload of the active component has been doubled without any performance limitation. Secondly, a dedicated encapsulation technique combined with the use of high temperature material allow to dissipate and withstand heat generation. Thirdly, a new generation of Switching Amplifier, called SA, has been developed to drive these powerful actuators at their maximum possible energy (see §8.1.4. *Switching voltage amplifiers*, page 106).

Any APA® or PPA actuator can now be supplied with an encapsulation option and their preload can be improved if required. As an example, an encapsulated PPA80L (see Fig. 3.r and Fig. 3.s) has been driven continuously at full stroke up to 1 000 Hz, whereas its standard version does not exceeds 50 Hz. These powerful piezo actuators are commonly used in manufacturing process for vibration assistance or acoustic generation and operate within harsh/humid environments.

Other examples of applications of forced vibrations using CTEC's products are given in:

[cedrat-tec.com/technologies/actuators/sonic-ultrasonic-generators](http://cedrat-tec.com/technologies/actuators/sonic-ultrasonic-generators)



Fig. 3.j: XY stage based on APA25XS used for micro-scanning



Fig. 3.k: XY stage based on MICA™ used for stabilisation



Fig. 3.l: Servo Piezo Tool SPT400MML

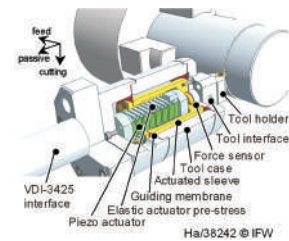

Fig. 3.m: Smart Tool based on PPA60L (courtesy of IFW)



Fig. 3.n: An educational ACV Kit, based on this technique is available as a standard product



Fig. 3.o: Active fixture using MICA™

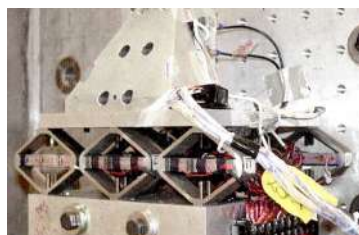

Fig. 3.p: Piezoelectric shaker (courtesy of Sandia Lab)



Fig. 3.q: AVIBUS VAD tool holder



Fig. 3.r: From standard to encapsulated piezo actuators: PPA801L to PPA80L-E

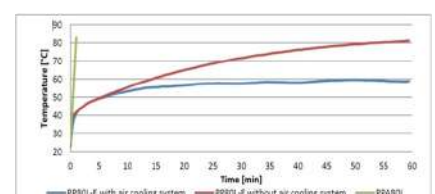

Fig. 3.s: Temperature rise at 235Hz, full stroke

### 3.2.3. APPLICATIONS OPERATED UNDER DYNAMIC RESONANT CONDITIONS

#### PIEZO VIBRATORS OPERATING AT RESONANCE

CEDRAT TECHNOLOGIES (CTEC) Parallel Pre-stressed Actuators (PPA) and Amplified Piezoelectric Actuators (APA®) are also successfully used in resonant mode for vibration generation at a fixed frequency in that case full stroke is achieved with less than 10 V instead of 170 V in quasi static conditions.

In some cases, special interfaces are useful, for example the Ultrasonic Piezo Actuators (UPA) deriving from the APA® have been developed to offer a more compact solution than Langevin transducers for the generation of ultrasonic vibrations. UPA structures are the same as APA® structures, but they are maintained on the side of the long axis in order to decouple the support from the vibration generation (free-free mode).

UPA are customised products finding applications in machining (for example ultrasonic engraving) or in ultrasonic piezo motors.

#### COMPRESSORS, EXPANDERS, PUMPS

Dynamic resonant conditions are used when the working frequency is well-defined and low electrical power is needed. These conditions perfectly fit with balanced

compressor, and pump applications, using low vibration back to back linear reciprocators. Moving Iron Controllable Actuators (MICA™) are well-suited for resonant conditions since they feature high efficiency to provide high output force, with low electrical input power. They feature also ultra-long lifetime, using frictionless, and free of lubricant, flexure bearings. Custom output mechanical power can range from 3 W to higher than 1000 W on demand, with housing designs featuring fluid leak tightness, bio-compatibility.

Resonant MICA™ flexure bearings actuators are especially relevant as pressure wave generators, or expanders inside high frequency Stirling machines, for wasted heat energy recovery, refrigerators, and cryogenic coolers, as well as positive displacement compressors, using reed valves, inside Rankine and Joules Thomson machines.

#### FOOD CUTTING

The actuator designed exhibits large stroke and high working frequency which is particularly relevant for a cutting function. The linear motion allows direct drive of the cutting tools, leading to simplicity and noise reduction of the whole system. Flexible guiding offer extended lifetime, increasing the intervals of maintenance in production.



Fig. 3.t: View of an Ultrasonic Piezo Actuator (UPA)



Fig. 3.u: Moving cylinder MICA™ actuator for pump and compressor



Fig. 3.v: Moving piston MICA™ actuators for pump and compressor

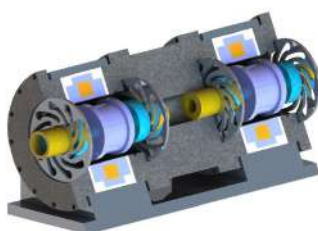

Fig. 3.w: CAD integration of MICA™ inside back to back balanced compressors



Fig. 3.x: Vibrating Food Cutter using MICA™

### 3.2.4. APPLICATIONS OPERATED UNDER DYNAMIC FORCE CONDITIONS

#### PROOF-MASS ACTUATOR

A Proof-Mass Actuator aims at generating dynamic forces into a structure to either excite vibrations in the structure (proof-mass shaker) or to damp vibrations of the structure (proof-mass dampers).

CTEC piezoelectric proof-mass dampers are made of an APA<sup>®</sup>, a back mass fixed on one side of the actuator, and optionally some guiding functions (Fig. 3.y). The second side of the actuator is fixed on the structure. By reaction, because of mass inertia, dynamic forces can be produced in the structure at the resonance frequency and above resonance. In this condition, the Proof Mass Actuator may provide dynamic forces up to the APA<sup>®</sup> blocked force.

Standard MICA<sup>™</sup> actuators have been successfully integrated inside milling machine, to perform active vibration damping in a proof mass configuration. For such a configuration, MICA<sup>™</sup> with flexural bearing (see §7.1. *Moving Iron Controllable Actuator MICA<sup>™</sup>*, page 92) is preferred. Then there are different possibilities for the reaction masses. The actuator can be fixed to the structure via its moving part, then the stator plays the role of the reaction mass. Alternately, the actuator can be fixed to the structure via its stator, then the moving part plays the role of the reaction mass. In that case, an additional mass is generally added to the moving part in order to tune the resonant frequency.

This work has been performed in the frame of the DynXpert FP7 project “Factories of the Future” (see Fig. 3.aa). The main purpose of the MICA<sup>™</sup> integration was to suppress the chatter occurring at different ranges of frequency. Standard MICA<sup>™</sup> actuators are capable of providing forces up to 1000 N, working at low to high frequency. The main advantages of MICA<sup>™</sup> actuators are the capabilities to be integrated in relatively small allowed volumes for the requested force, and the capabilities to withstand harsh environment such as vibrations, shocks, and high ambient temperature that can be found in machining tools. Derived from this successful R&D activity, standard MICA-based Tunable Proof-Mass Actuators are commercialised (see §7.3. *Tunable proof mass actuators*, page 96).



Fig. 3.y: PMA900M Proof Mass Actuator



Fig. 3.z: MICA 300CM proof-mass

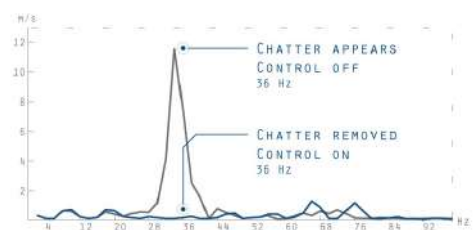
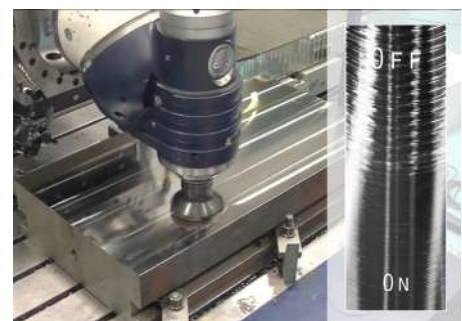

Fig. 3.aa: Active vibration damping through MICA<sup>™</sup>

### 3.2.5. APPLICATIONS OPERATED UNDER IMPULSE CONDITIONS

#### FAST & PRECISE VALVES



Fig. 3.ab: Pneumatic piezo valve

The well-known advantages (rapid response and precise positioning) of Amplified Piezoelectric Actuators (APA®) have been used in valve designs to obtain both rapid and precise-flow proportional valves.

A first gas valve (see Fig. 3.ab) was manufactured using a small APA® (APA120S) and was further driven with a switched amplifier to get a high frequency modulation. A frequency bandwidth higher than 400 Hz with a stroke of 100 µm has been measured. These properties can also be used for gasoline injectors.

CEDRAT TECHNOLOGIES (CTEC) has already designed and developed hydraulic piezo valves within the European project FP6 MESEMA. CTEC is also providing space piezo valves under ESA contracts for the propulsion of micro satellites or under CNES-ARIANE contracts. Using a dedicated test bench (Fig. 3.ac), APA-based piezo valves (Fig. 3.ad), are developed for fine pressure regulation for ARIANE 6 launcher. Such piezo valves offer advantages to solenoid valves for example to reduce power consumption. However solenoid valves are still developed by CTEC, especially based on MICA™ actuators for large fast & precise flow control..

For specific designs of piezo valves, please contact CTEC or visit:

[cedrat-tec.com/technologies/actuators/electro-fluidic-devices](http://cedrat-tec.com/technologies/actuators/electro-fluidic-devices)

#### LONG-STROKE ACTUATION WITH STEPPING PIEZOELECTRIC ACTUATORS (SPA) PIEZO MOTOR

SPA are piezo motors for long stroke actuation whose principle and product characteristics are introduced in section §2.1.6. *Stepping Piezo Actuators SPA, page 19*. An SPA is basically an Amplified Piezoelectric Actuator (APA®) exploiting both slow and fast strains to get stick slip effects. Thus the SPA uses the APA® under Impulse strain conditions.

As a first consequence, the SPA takes advantage of the APA® pre-stress to demonstrate the following performances:

- fast response time,
- ability to withstand external vibrations,
- robust structure (no dismounting during operation),
- good resistance to transverse forces...

As a second consequence, all APA® offering good dynamic capabilities can be used to make new SPA. Therefore new customised SPA can easily be developed upon request from the large range of standard APA®.

The LSPA30uXS (Fig. 3.af) is an example of customised miniature piezo-motor developed for a MRI-compatible medical implant. It is based on the SPA motor concept and the APA30uXS micro actuator. This motor is fully-non magnetic, passing MRI tests. Its mass is less than 1 gr.



Fig. 3.ac: Bench for testing pressure-regulation piezo valve for ARIANE 6 launcher

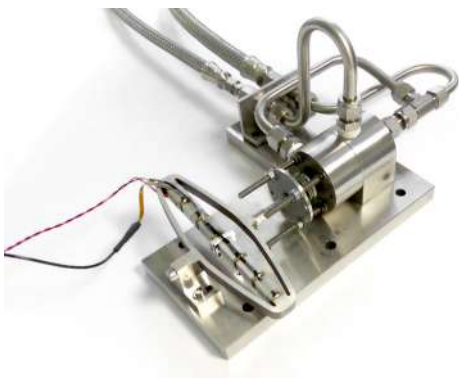

Fig. 3.ad: Pressure-regulation APA-based piezo valve for ARIANE 6 launcher



Fig. 3.af: LSPA30uXS piezo motor

It performs stroke of 3 mm with a controllable speed from 0 to 70 mm/s. The blocking force at rest is higher than 0.5 N while the actuation force is higher than 0.2 N.

The SPA technology has received a Golden Micron award at MICRONORA 2008 micro technology fair because of its relevance for precision and miniaturisation positioning functions.

Examples of CTEC piezo motors and applications are given in:

[cedrat-tec.com/technologies/actuators/piezo-motors-and-electronics](http://cedrat-tec.com/technologies/actuators/piezo-motors-and-electronics)

### MULTI-AXIS ACTUATION WITH SPA PIEZO MOTOR

Multi degree of freedom (dof) mechanisms are widely required into micro or macro manipulation fields as well as in optronics functions. Thanks to their versatility and robustness, SPA motors can be combined to generate such multi-axis movement.

The patented Tripod Actuator (TrAC) is a 3 degrees of freedom mechanism offering  $\pm 35^\circ$  rotation around X and Y axis and a 10 mm Z translation stroke into a low volume of  $\varnothing 50 \times 50$  mm.

This large displacement capability is combined with a 3 mrad /  $6 \mu\text{m}$  fine positioning mode allowing to achieve micro-radian and nanometric pointing or positioning resolutions.

Watch our video: [youtu.be/rsO9uqS6cbk](https://youtu.be/rsO9uqS6cbk)



Fig. 3.ag: Tripod Actuator TrAC

## 3.2.6. APPLICATIONS OPERATED UNDER DYNAMIC SENSING CONDITIONS

### PIEZO GENERATORS & ENERGY HARVESTING

Piezo actuators can also be used as electric generators. When subjected to an external source of vibration or to a shock, a piezo actuator produces electrical energy.

Among different actuators, APA<sup>®</sup> are good candidates to perform such a function with reliability and efficiency because they are pre-stressed and because their shell contributes to a favourable dynamic stress distribution.

It has been demonstrated for example that a small APA<sup>®</sup> encapsulated within a frame box can produce 4mW power at 400 Hz (see Fig. 3.ah).

CTEC can develop customised piezo generators using its range of standard piezo actuators. Examples of other piezo harvesting applications are given in:

[cedrat-tec.com/technologies/mechatronic-systems/energy-harvesting](http://cedrat-tec.com/technologies/mechatronic-systems/energy-harvesting)



Fig. 3.ah: Energy piezo harvester based on APA50XS actuator

### 3.3. ADDITIONAL TECHNOLOGICAL SOLUTIONS

This section presents technological solutions that can be proposed in addition to technological solutions introduced in section §3.1. *Market overview, page 43* or to standard products described in chapters 4, page 57 to 7, page 91.



Fig. 3.ai: HPPA for the first European space Lidar, Aladin / Aeolus (courtesy of Galileo Avionica)

#### 3.3.1. HOLLOW PARALLEL PRESTRESSED ACTUATOR HPPA

CEDRAT TECHNOLOGIES (CTEC) has delivered some annular multilayers piezo ceramics pre-stressed (preloaded) by an external elastic frame. This structure called Hollow Parallel Prestressed Actuator (HPPA) allows to increase the life time and reliability of the piezo rings under severe environment (high level of vibrations) and in dynamic applications. It enables to reach very high frequencies, with a resonance over kHz. Several HPPA, including flight models, have been delivered for various space missions.

#### 3.3.2. EXTREMELY AMPLIFIED ACTUATORS

The Amplified Piezoelectric Actuators (APA®) shape is a highly effective amplification mechanism offering a high efficiency. However, it is sometimes required to achieve even larger displacements.

A second stage amplification is then a good solution to build an extremely amplified actuator. Very compact actuators can provide high displacement, with amplification ratio up to 40 or more. Careful design is needed with these actuators to preserve acceptable stiffness and positioning stability. The Fig. 3.aj shows a two-stages amplified and monolithic actuator developed for a synchrotron beam shaping mechanism, with a stability under the micron, for a displacement of 400 μm.



Fig. 3.aj: Two-stages amplified and monolithic actuator designed with SOLEIL for the SixS beamline



### 3.3.3. APPLICATIONS REQUIRING A HIGH STABILITY IN CLOSED LOOP

Many applications require long-term position stability, which relates to the notion of absolute precision over time. CTEC has demonstrated nanometric position stability of a closed-loop piezo-mechanism with integrated strain gages sensors. This technology opens a wide range of new possibilities for industrial, aeronautical, and space applications. In the nanometric range, contributions that are usually considered negligible become main contributors. Dedicated test equipment has been set-up in order to perform high precision instrumentation of systems, based on a high precision laser interferometer. Measurements are done in a primary vacuum chamber and with thermal control.

The resolution can reach the nanometric range, with a tested 500 hours stability of  $\pm 10$  nm (see Fig. 3.ak)

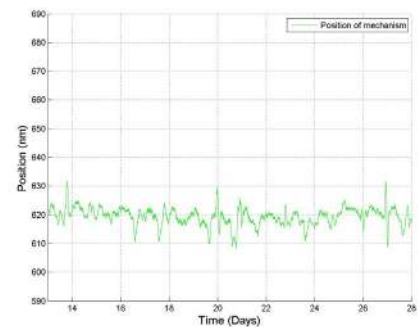

Fig. 3.ak: Stability test of two weeks long

### 3.3.4. MECHANICALLY-DAMPED AMPLIFIED PIEZOELECTRIC ACTUATORS APA®

In some applications (operations under external vibrations, impulse response), it is interesting to use an actuator that displays a low mechanical Quality factor. A low Q factor reduces the amplification at resonance and the stress levels.

The large range of APA® can be mechanically damped by adding some elastomer parts in the actuator. A Q factor below 5 is achievable.

Please contact CTEC to customise Mechanically Damped APA® (MD option) as a function of your environmental parameters (temperature, vibration level... ).



Fig. 3.al: View of an APA400M-MD

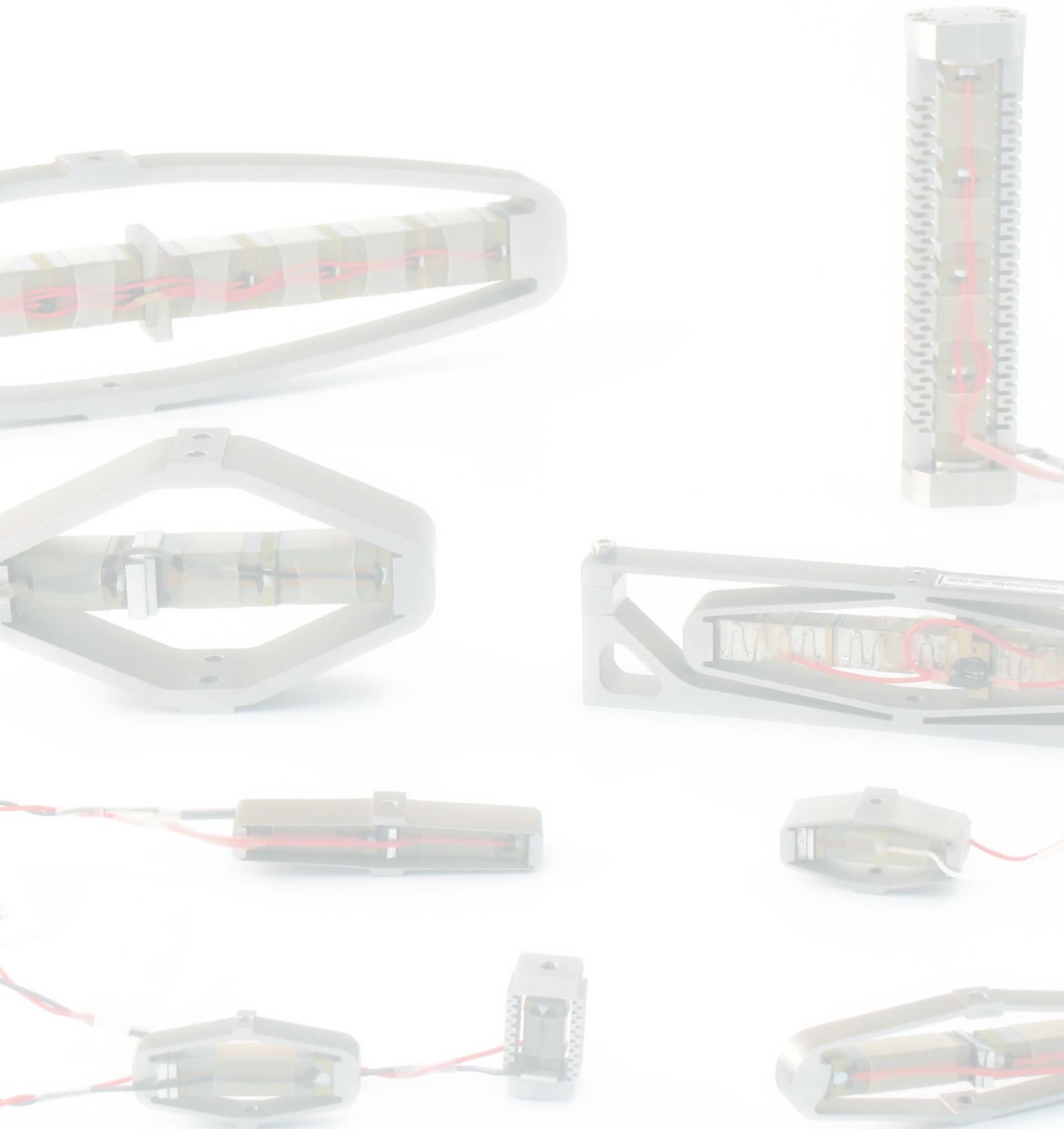

**For more information on this chapter,  
please visit these pages:**

[cedrat-tec.com/products/actuators/apa](https://cedrat-tec.com/products/actuators/apa)

[cedrat-tec.com/products/actuators/parallel-pre-stressed-actuators](https://cedrat-tec.com/products/actuators/parallel-pre-stressed-actuators)

[cedrat-tec.com/technologies/actuators/piezo-actuators-and-electronics](https://cedrat-tec.com/technologies/actuators/piezo-actuators-and-electronics)

## 4. PIEZO ACTUATORS

### 4.1. SELECTION GUIDE

#### 4.1.1. INTRODUCTION

CEDRAT TECHNOLOGIES (CTEC) offers a wide range of commercially off-the-shelf actuators: Amplified Piezoelectric Actuators (APA®), Parallel Pre-Stressed Actuators (PPA) and conventional Multilayer Actuators (MLA). These actuators benefit from 20 years of space heritage and industrialisation efforts. Several options are available and most of the actuator's functional properties, mechanical or electrical interfaces can be modified to meet the customer's needs. Please do not hesitate to contact CTEC for more information about an actuator's additional features.



Fig. 4.a: Products naming

RANGE OF PRODUCT	BLOCKED FORCE MIN-MAX	STROKE MIN-MAX
APA XXS	3.2	130
APA uXS	2.7	34
APA XS	16 - 27	52 - 66
APA S	46 - 130	75 - 140
APA SM	140 - 260	54 - 77
APA M	18 - 240	130 - 790
APA MML	78 - 830	100 - 650
APA ML	540 - 3300	65 - 300
APA L	62 - 1 300	230 - 2000
APA XL	770 - 1 400	590 - 1 100
PPA M	850	8.3 - 38
PPA L	3500	44 - 130
PPA XL	7000	43 - 130
MLA	400 - 9 300	10 - 20

Table 4.a APA® and PPA blocked force and stroke

## 4.1.2. MECHANICAL INTERFACE OPTIONS

### TH - THREADED HOLE

The actuator has two identical mechanical interfaces: a flat interface with a centred threaded hole.

### FI - FLAT INTERFACE

The actuator has two identical flat interfaces that can be bonded.

### H - HOLE

The actuator has two identical mechanical interfaces: a flat interface with a non threaded hole.

### SI - SPECIFIC INTERFACE

In order to make the mechanical integration of its actuators easier as OEM products, Cedrat Technologies (CTEC) can design and machine a Specific Interface on top of its actuators to meet the customer's needs. For any question regarding mechanical integration, please contact CTEC.

## 4.1.3. STANDARD OPTIONS

### SG - STRAIN GAUGES

The SG option consists in gluing strain gauges to the piezo ceramics stack. This allows monitoring the ceramics strain and thus the displacement of the piezo actuator (See Fig. 4.b and 9.2, page 122). Standard SG is connected via a flex cable; other plugs are available on request. The SG signal is conditioned by the SG75 electronic board integrated in a rack amplifier. Adding a digital controller board allows a closed loop control.

### NM - NON MAGNETIC

With this option the actuator is made of non-magnetic (NM) material: it does not disturb any external magnetic field and is also completely insensitive to an external applied magnetic field.

Some properties (e.g. thermo-mechanical behaviour, mass, width, characteristics) may differ from the standard actuator's features.

*Note: NM and TC options are not compatible.*

### VAC - VACUUM UHV - ULTRA HIGH VACUUM

Our actuators can be compatible with vacuum environment, with one of these two options.

The VAC option consists in adapting the integration process to avoid the presence of any dust and make the actuator compatible with vacuum environment. The VAC option is generally used till down  $10^{-6}$  mbar.

The UHV option goes further with a specific integration process and the adaptation of materials used. The UHV option is compatible with vacuum down to  $10^{-9}$  mbar. It enables low outgasing or proximity of optical components.

Would you have any specific constraints, as for space projects, please contact us with your requirements.

### TS - THERMOCOUPLE SENSOR

For certain dynamic applications, it may be necessary to follow up the self heating of the piezo ceramic in order to avoid overheating and damages.

For such application cases, we developed a dedicated option where we bond a thermocouple sensor on the piezo ceramic in order to monitor its inner temperature.

## 4.1.4. SPECIFIC VERSIONS

### CFRP - CARBON FIBRE REINFORCED POLYMER

The CFRP option relates to the use of a CFRP composite instead of metal to make the APA® shell.

This change leads to several advantages: significant mass reduction, higher bandwidth, lower Q-factor, much lower thermal expansion

This option results of a collaboration with ONERA considering helicopter flap applications (See Fig. 4.c).

### HT - HIGH TEMPERATURE

The HT option refers to special piezo material and processes (bonding) that can be used to build High Temperature piezoelectric actuators.

### TC - THERMO-COMPENSING

The TC option is a special construction which allows the improvement of the behaviour within a wide temperature range, especially at the liquid nitrogen temperature

(77 °K); Its objective is to reduce the actuator coefficient of thermal expansion.

*Note: NM and TC options are not compatible.*

## G - GUIDING

To obtain a better dynamic movement, it is possible to add a flexible guiding to the actuator's shell. This can be added at the application integration level or designed monolithically with the shell. Please contact CTEC to discuss your application.



Fig. 4.b: APA500XL-SG

## E - ENCAPSULATION

Designed encapsulation with cooling systems overcome overheating limitation. Compared to regular version of the actuator the driving frequency has increased 20 times for encapsulated actuator with air cooling system. The encapsulated actuator benefits from heat sinking structure and without air cooling system can be used at frequency that is nearly 5 times higher compared to regular actuator (See Fig. 4.d).



Fig. 4.c: ECP test bench for APA500L-CFRP-ECS

## ECP - EDDY CURRENT PROBE

The ECP option refers to an APA® equipped with an ECP sensor. The ECP sensor providing a nanometric resolution and a direct measurement of the displacement of the head of the actuator, this option gives the best precision possible. The ECP sensor signal is monitored with the ECS75 conditioner board (See Fig. 4.e and chapter 9.3, page 124).



Fig. 4.d: High temperature encapsulation on PPA80L-E

## MD - MECHANICAL DAMPING (PRELIMINARY)

The MD option consists in added elastomeric parts inside the APA®. This option provides damping and lowers the Q-factor at resonance (see chapters 3.2.3, page 50 and 3.3.4, page 55). This also reduces overshoot in on-off applications and improves resistance to external vibration. This option results of R&T works for CNES.



Fig. 4.e: Test bench for APA2000L

## SV - SPECIFIC VERSION

In some cases, the change of mechanical interfaces or the piezo components on the shell materials leads to a modification of the functional properties. In that case, the Specific Version of an existing standard actuator is called the SV option. For any question regarding mechanical integration, please contact CTEC (See Fig. 4.f).



Fig. 4.f: Specific Version Twin Amplified Piezoelectric Actuator APA®

## 4.2. AMPLIFIED PIEZOELECTRIC ACTUATORS APA®

### 4.2.1. APA® UXS & XXS SERIES

Some applications of APA® uXS and XXS are:

- Earing implants
- Actuation in Micro Aerial Vehicle
- Energy harvester for pacemaker
- Micro electro optical systems

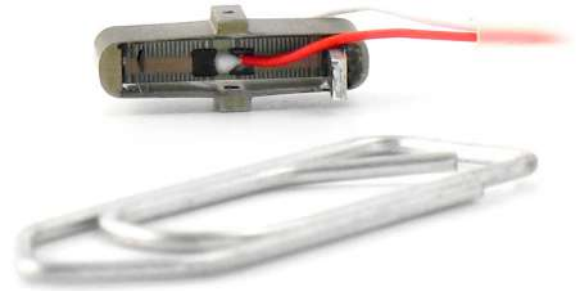

Fig. 4.g: APA150XXS

> [See APA30UXS full datasheet](#)

> [See APA150XXS full datasheet](#)

PARAMETER	UNIT	APA30UXS <sup>(B.3)</sup>	APA150XXS
Nominal stroke	µm	34	130
Blocked force	N	3.7	3.2
Stiffness	N/µm	0.11	0.024
Resolution <sup>(b.1)</sup>	nm	1.9	7.4
Force limit (0-peak) <sup>(b.2)</sup>	N	7.5	2.2
Free - Free resonance frequency	Hz	25 000	3 800
Blocked - free resonance frequency	Hz	4 800	1 100
Thermomechanical behaviour	µm/K	0.33	1.6
Voltage range	V	-20 ... 150	
Capacitance	µF	0.043	0.18
Height	mm	4.0	4.5
Length	mm	8.6	14
Width (incl. Wedges, wires)	mm	5.0	9.0
Mass (excl. Wires)	g	0.15	1.3
Available options <sup>(b.4)</sup>			VAC
Specific versions <sup>(b.5)</sup>			TC
Available interfaces <sup>(b.6)</sup>			FI H

Table 4.b Characteristics of APA® uXS and XXS series

b.1 With amplifier SNR of 85dB

b.2 External on-axis pulling or pushing force limit. Inertial forces should be assimilated as external forces.

b.3 Non magnetic configuration only

b.4 Refer to §4.1.3. Standard options, page 58

b.5 Refer to §4.1.4. Specific versions, page 58

b.6 Refer to §4.1.2. Mechanical interface options, page 58

### 4.2.2. APA® XS SERIES

Some applications with APA® XS are:

- Micro optical mechanisms
- Micro controllable dynamic valves
- Space qualified micro tip tilts
- Miniature brakes

> [See APA35XS full datasheet](#)

> [See APA50XS full datasheet](#)



Fig. 4.h: APA35XS

PARAMETER	UNIT	APA35XS	APA50XS
Nominal stroke	µm	52	66
Blocked force	N	27	16
Stiffness	N/µm	0.52	0.24
Resolution <sup>(c.1)</sup>	nm	2.9	3.7
Force limit (0-peak) <sup>(c.2)</sup>	N	37	13
Free - Free resonance frequency	Hz	18 000	12 000
Blocked - free resonance frequency	Hz	3 900	2 700
Thermomechanical behaviour	µm/K	0.69	0.83
Voltage range	V	-20...150	
Capacitance	µF	0.30	
Height	mm	5.5	4.7
Length	mm	13	13
Width (incl. Wedges, wires)	mm	9.0	
Mass (excl. Wires)	g	2.0	
Available options <sup>(c.3)</sup>		SG NM VAC	NM VAC
Specific versions <sup>(c.4)</sup>		TC	
Available interfaces <sup>(c.5)</sup>		TH FI H	

Table 4.c Characteristics of APA® XS series

c.1 With amplifier SNR of 85dB

c.2 External on-axis pulling or pushing force limit. Inertial forces should be assimilated as external forces.

c.3 Refer to §4.1.3. Standard options, page 58

c.4 Refer to §4.1.4. Specific versions, page 58

c.5 Refer to §4.1.2. Mechanical interface options, page 58

### 4.2.3. APA® S SERIES

Some applications with APA® S are:

- Shaking powder for X-ray diffraction
- Optical stabilization for embedded cameras
- Space qualified optical stages
- Nano-indentation

> [See APA60S full datasheet](#)

> [See APA120S full datasheet](#)



Fig. 4.i: APA60S

PARAMETER	UNIT	APA60S	APA120S
Nominal stroke	µm	75	140
Blocked force	N	130	46
Stiffness	N/µm	1.7	0.33
Resolution <sup>(d.1)</sup>	nm	4.2	7.9
Force limit (0-peak) <sup>(d.2)</sup>	N	120	32
Free - Free resonance frequency	Hz	13 000	7 200
Blocked - free resonance frequency	Hz	2 900	1 300
Thermomechanical behaviour	µm/K	1.1	1.7
Voltage range	V	-20 ... 150	
Capacitance	µF	1.1	
Height	mm	15	13
Length	mm	29	29
Width (incl. Wedges, wires)	mm	9.0	
Mass (excl. Wires)	g	8.5	7.2
Available options <sup>(d.3)</sup>		SG NM VAC TS	
Specific versions <sup>(d.4)</sup>		HT TC	
Available interfaces <sup>(d.5)</sup>		TH FI H	

Table 4.d Characteristics of APA® S series

d.1 With amplifier SNR of 85dB

d.2 External on-axis pulling or pushing force limit. Inertial forces should be assimilated as external forces.

d.3 Refer to §4.1.3. Standard options, page 58

d.4 Refer to §4.1.4. Specific versions, page 58

d.5 Refer to §4.1.2. Mechanical interface options, page 58



#### 4.2.4. APA® SM SERIES

Some applications with APA® SM are:

- Shock energy harvester in wireless switches
- Material Stress cycling
- Injectors

> [See APA40SM full datasheet](#)

> [See APA60SM full datasheet](#)



Fig. 4.j: APA60SM

PARAMETER	UNIT	APA40SM	APA60SM
Nominal stroke	µm	54	77
Blocked force	N	260	140
Stiffness	N/µm	4.9	1.8
Resolution <sup>(e.1)</sup>	nm	3.0	4.3
Force limit (0-peak) <sup>(e.2)</sup>	N	170	110
Free - Free resonance frequency	Hz	15 000	10 000
Blocked - free resonance frequency	Hz	4 100	2 800
Thermomechanical behaviour	µm/K	0.79	1.1
Voltage range	V	-20 ... 150	
Capacitance	µF	1.1	
Height	mm	15	13
Length	mm	27	27
Width (incl. Wedges, wires)	mm	12	
Mass (excl. Wires)	g	11	10
Available options <sup>(e.3)</sup>		SG VAC TS	
Specific versions <sup>(e.4)</sup>		HT TC	
Available interfaces <sup>(e.5)</sup>		TH FI H	

Table 4.e Characteristics of APA® SM series

e.1 With amplifier SNR of 85dB

e.2 External on-axis pulling or pushing force limit. Inertial forces should be assimilated as external forces.

e.3 Refer to §4.1.3. Standard options, page 58

e.4 Refer to §4.1.4. Specific versions, page 58

e.5 Refer to §4.1.2. Mechanical interface options, page 58

## 4.2.5. APA® M SERIES

Some applications with APA® M are:

- Fast X-Ray vacuum compatible shutters
- Dynamic valves
- Laser cavity tuning
- Miniature Active flaps for aero vehicles

> [See APA100M full datasheet](#)

> [See APA150M full datasheet](#)

> [See APA200M full datasheet](#)

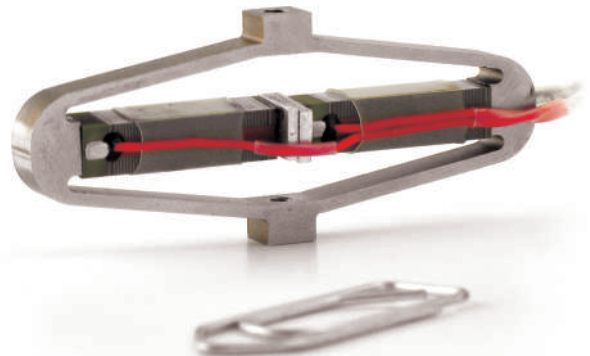

Fig. 4.k: APA150M

PARAMETER	UNIT	APA100M	APA150M	APA200M
Nominal stroke	µm	130	190	240
Blocked force	N	240	130	87
Stiffness	N/µm	1.9	0.68	0.37
Resolution <sup>(f.1)</sup>	nm	7.0	10	13
Force limit (0-peak) <sup>(f.2)</sup>	N	150	98	56
Free - Free resonance frequency	Hz	8 000	5 000	4 600
Blocked - free resonance frequency	Hz	1 900	1 300	910
Thermomechanical behaviour	µm/K	1.5	2.0	2.4
Voltage range	V	-20...150		
Capacitance	µF	2.2		
Height	mm	25	22	17
Length	mm	55		
Width (incl. Wedges, wires)	mm	9.0		
Mass (excl. Wires)	g	20	17	16
Available options <sup>(f.3)</sup>		SG NM VAC TS		
Specific versions <sup>(f.4)</sup>		ECP HT TC G E		
Available interfaces <sup>(f.5)</sup>		TH FI H		

Table 4.f Characteristics of APA® M series

f.1 With amplifier SNR of 85dB

f.2 External on-axis pulling or pushing force limit. Inertial forces should be assimilated as external forces.

f.3 Refer to §4.1.3. Standard options, page 58

f.4 Refer to §4.1.4. Specific versions, page 58

f.5 Refer to §4.1.2. Mechanical interface options, page 58

## 4.2.6. SUPER APA® M SERIES

Some applications with super amplified APA® M are:

- Clamping in wire feeding system
- Inverted microscope positionner
- Haptic technology feedback for display panels
- Energy harvesters

> [See APA400M full datasheet](#)

> [See APA600M full datasheet](#)

> [See APA900M full datasheet](#)

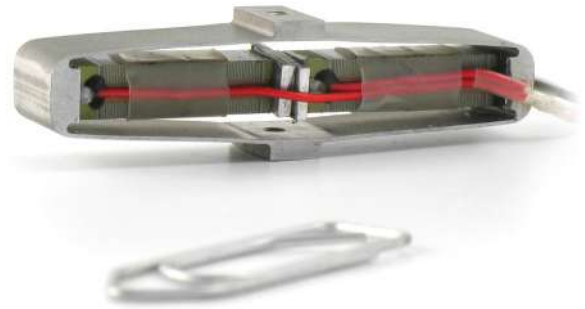

Fig. 4.I: APA400M

PARAMETER	UNIT	APA400M	APA600M	APA900M <sup>(g.3)</sup>
Nominal stroke	µm	460	550	790
Blocked force	N	34	24	18
Stiffness	N/µm	0.07	0.043	0.023
Resolution <sup>(g.1)</sup>	nm	26	31	44
Force limit (0-peak) <sup>(g.2)</sup>	N	21	16	1.7
Free - Free resonance frequency	Hz	1 800	1 300	1 100
Blocked - free resonance frequency	Hz	420	320	260
Thermomechanical behaviour	µm/K	4.8		7.8
Voltage range	V	-20...150		
Capacitance	µF	2.2		
Height	mm	13	13	10
Length	mm	48	49	49
Width (incl. Wedges, wires)	mm	12		
Mass (excl. Wires)	g	15	14	12
Available options <sup>(g.4)</sup>		SG VAC TS		VAC TS
Specific versions <sup>(g.5)</sup>		HT TC G E		
Available interfaces <sup>(g.6)</sup>		TH FI H		

Table 4.g Characteristics of super APA® M series

g.1 With amplifier SNR of 85dB

g.2 External on-axis pulling or pushing force limit. Inertial forces should be assimilated as external forces.

g.3 Use limited to quasistatic operations

g.4 Refer to §4.1.3. Standard options, page 58

g.5 Refer to §4.1.4. Specific versions, page 58

g.6 Refer to §4.1.2. Mechanical interface options, page 58

### 4.2.7. APA® MML SERIES

Some applications with APA® MML are:

- Active stabilisation of a watt balance
- High frequency shakers
- Elasto MRI
- Long range cavity modulation in interferometers



Fig. 4.m: APA400MML

- > [See APA100MML full datasheet](#)
- > [See APA400MML full datasheet](#)
- > [See APA600MML full datasheet](#)

PARAMETER	UNIT	APA100MML <sup>(h.3)</sup>	APA400MML	APA600MML
Nominal stroke	µm	100	360	650
Blocked force	N	830	180	78
Stiffness	N/µm	8.3	0.52	0.12
Resolution <sup>(h.1)</sup>	nm	5.6	20	37
Force limit (0-peak) <sup>(h.2)</sup>	N	510	150	47
Free - Free resonance frequency	Hz	6 500	2 800	1 500
Blocked - free resonance frequency	Hz	1 700	630	320
Thermomechanical behaviour	µm/K	0.60	3.8	7.9
Voltage range	V		-20...150	
Capacitance	µF		6.3	
Height	mm	58	24	17
Length	mm	85	78	
Width (incl. Wedges, wires)	mm	12		
Mass (excl. Wires)	g	76	48	41
Available options <sup>(h.4)</sup>		SG VAC TS		
Specific versions <sup>(h.5)</sup>		ECP HT TC G E		HT TC G E
Available interfaces <sup>(h.6)</sup>		TH FI H		

Table 4.h Characteristics of APA® MML series

*h.1 With amplifier SNR of 85dB*

*h.2 External on-axis pulling or pushing force limit. Inertial forces should be assimilated as external forces.*

*h.3 Preliminary data*

*h.4 Refer to §4.1.3. Standard options, page 58*

*h.5 Refer to §4.1.4. Specific versions, page 58*

*h.6 Refer to §4.1.2. Mechanical interface options, page 58*

### 4.2.8. APA® ML SERIES

Some applications with APA® ML are:

- Active control of vibration on medical robots
- High frequency shakers
- Fretting fatigue testing
- Space qualified positioner



Fig. 4.n: APA120ML

> [See APA95ML full datasheet](#)

> [See APA120ML full datasheet](#)

> [See APA200ML full datasheet](#)

> [See APA300ML full datasheet](#)

PARAMETER	UNIT	APA95ML	APA120ML	APA200ML <sup>(i.3)</sup>	APA300ML <sup>(i.3)</sup>
Nominal stroke	µm	99	120	220	300
Blocked force	N	2 100	1 500	780	540
Stiffness	N/µm	21	12	3.6	1.8
Resolution <sup>(i.1)</sup>	nm	5.6	6.7	12	17
Force limit (0-peak) <sup>(i.2)</sup>	N	1 100	910	470	1 700
Free - Free resonance frequency	Hz	6 500	5 800	4 200	3 100
Blocked - free resonance frequency	Hz	2 100	1 900	1 000	760
Thermomechanical behaviour	µm/K	1.6	1.7	1.9	3.3
Voltage range	V	-20 ... 150			
Capacitance	µF	13			
Height	mm	60	45	34	30
Length	mm	80	79	79	79
Width (incl. Wedges, wires)	mm	23			
Mass (excl. Wires)	g	160	160	120	110
Available options <sup>(i.4)</sup>		SG VAC TS			
Specific versions <sup>(i.5)</sup>		ECP CFRP TC G E			
Available interfaces <sup>(i.6)</sup>		TH FI H			

Table 4.i Characteristics of APA® ML series

i.1 With amplifier SNR of 85dB

i.2 External on-axis pulling or pushing force limit. Inertial forces should be assimilated as external forces.

i.3 Preliminary data

i.4 Refer to §4.1.3. Standard options, page 58

i.5 Refer to §4.1.4. Specific versions, page 58

i.6 Refer to §4.1.2. Mechanical interface options, page 58

## 4.2.9. APA® L SERIES

Some applications with APA® L are:

- Helicopter flaps
- High frequency shakers
- Material stress cycling
- Mirror positioning in telescopes & instruments

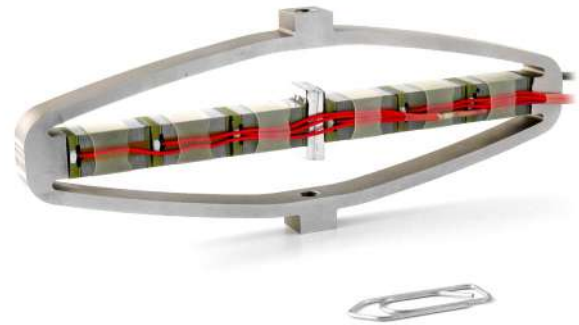

Fig. 4.o: APA500L

- > [See APA230L full datasheet](#)
- > [See APA500L full datasheet](#)
- > [See APA1000L full datasheet](#)
- > [See APA1500L full datasheet](#)
- > [See APA2000L full datasheet](#)

PARAMETER	UNIT	APA230L	APA500L	APA1000L	APA1500L	APA2000L <sup>(j.3)</sup>
Nominal stroke	µm	230	510	870	1 500	2000
Blocked force	N	1 300	580	350	99	62
Stiffness	N/µm	5.8	1.1	0.40	0.067	0.031
Resolution <sup>(j.1)</sup>	nm	13	29	49	83	110
Force limit (0-peak) <sup>(j.2)</sup>	N	910	430	110	72	21
Free - Free resonance frequency	Hz	3 100	2 000	1 300	720	520
Blocked - free resonance frequency	Hz	860	460	290	140	87
Thermomechanical behaviour	µm/K	3.6	6.7	11	18	21
Voltage range	V	-20 ... 150				
Capacitance	µF	26				
Height	mm	85	55	35	30	27
Length	mm	150			140	
Width (incl. Wedges, wires)	mm	16			20	
Mass (excl. Wires)	g	280	200	190	140	130
Available options <sup>(j.4)</sup>		SG NM VAC TS				
Specific versions <sup>(j.5)</sup>		ECP HT CFRP TC G E			ECP HT TC G E	
Available interfaces <sup>(j.6)</sup>		TH FI H				

Table 4.j Characteristics of APA® L series

*j.1 With amplifier SNR of 85dB*

*j.2 External on-axis pulling or pushing force limit. Inertial forces should be assimilated as external forces.*

*j.3 Preliminary data*

*j.4 Refer to §4.1.3. Standard options, page 58*

*j.5 Refer to §4.1.4. Specific versions, page 58*

*j.6 Refer to §4.1.2. Mechanical interface options, page 58*

## 4.2.10. APA® XL SERIES

Some applications with APA® XL are:

- High frequency shakers
- Fretting Fatigue testing
- Positioning of heavy loads
- Force Testing



Fig. 4.p: APA1000XL

- > [See APA500XL full datasheet](#)
- > [See APA1000XL full datasheet](#)

PARAMETER	UNIT	APA500XL	APA1000XL
Nominal stroke	µm	590	1 100
Blocked force	N	1 400	770
Stiffness	N/µm	2.4	0.70
Resolution <sup>(k.1)</sup>	nm	33	62
Force limit (0-peak) <sup>(k.2)</sup>	N	1 100	640
Free - Free resonance frequency	Hz	1 500	1 000
Blocked - free resonance frequency	Hz	350	210
Thermomechanical behaviour	µm/K	7.9	14
Voltage range	V	-20 ... 150	
Capacitance	µF	77	
Height	mm	82	57
Length	mm	210	
Width (incl. Wedges, wires)	mm	25	
Mass (excl. Wires)	g	650	600
Available options <sup>(k.3)</sup>		SG NM VAC TS	
Specific versions <sup>(k.4)</sup>		ECP CFRP TC G E	
Available interfaces <sup>(k.5)</sup>		TH FI H	

Table 4.k Characteristics of APA® XL series

k.1 With amplifier SNR of 85dB

k.2 External on-axis pulling or pushing force limit. Inertial forces should be assimilated as external forces.

k.3 Refer to §4.1.3. Standard options, page 58

k.4 Refer to §4.1.4. Specific versions, page 58

k.5 Refer to §4.1.2. Mechanical interface options, page 58

### 4.3. MULTI-LAYER ACTUATORS MLA SERIES

The Multi Layer Actuators MLA are non pre-stressed low voltage piezo ceramics. As a consequence, **they are not suited to high level dynamic operations.**

- Strain Gauges SG can be added on MLA upon request.
- Wired connections are secured through a tube shrink.
- MLA can be driven by CEDRAT TECHNOLOGIES (CTEC) linear amplifiers.

Expertise of on MLA results from several space evaluation programs performed for CNES and ESA on different types of MLA.

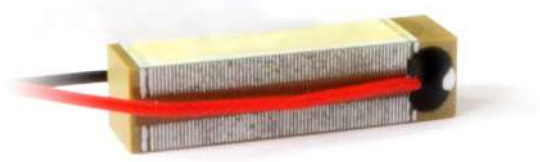

Fig. 4.q: MLA 5×5×20

PARAMETER	UNIT	2×5×10	5×5×10	5×5×20	10×10×20	14×14×20
Nominal stroke	µm	10		20		
Blocked force	N	400	1 100		4 700	9 300
Stiffness	N/µm	40	110	55	235	465
Resolution <sup>(I.1)</sup>	nm	0.56		1.1		
Free - Free resonance frequency	Hz	130 000		60 000		120 000
Thermomechanical behaviour	µm/K	1.0		2.0		
Voltage range	V	-20 ...150				
Capacitance	µF	0.22	0.55	1.2	4.4	8.7
Height	mm	2.0	5.0		10.0	14.0
Width (incl. Wedges, wires)	mm	9.0		16.0		20.0
Mass (excl. Wires)	g	0.8	1.9	3.8	15.0	30.0
Available options <sup>(I.2)</sup>		SG VAC				

Table 4.I Characteristics of MLA series

I.1 With amplifier SNR of 85 dB

I.2 Refer to §4.1.3. Standard options, page 58



## 4.4. PARALLEL PRE-STRESSED ACTUATORS PPA

### 4.4.1. PPA M SERIES

Some applications with PPA M are:

- Vibration assistance
- Needle vibrator in a space Atomic Force Microscope
- Active deformation of mirror in telescopes
- Ultrasonic injection

> [See PPA10M full datasheet](#)

> [See PPA20M full datasheet](#)

> [See PPA40M full datasheet](#)

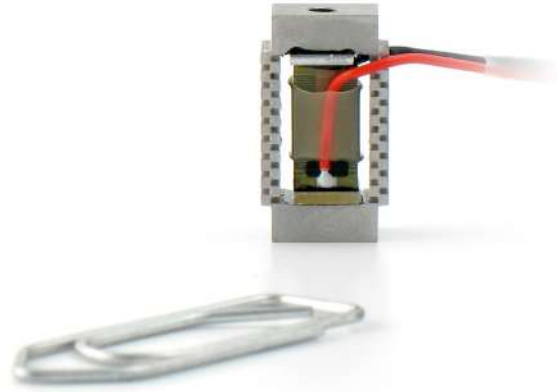

Fig. 4.r: PPA10M

PARAMETER	UNIT	PPA10M	PPA20M	PPA40M
Nominal stroke	μm	8.3	20	38
Blocked force	N		850	
Stiffness	N/μm	100	44	22
Resolution <sup>(m.1)</sup>	nm	0.47	1.1	2.1
Force limit (0-peak) <sup>(m.2)</sup>	N		500	
Free - Free resonance frequency	Hz	62 000	39 000	23 000
Blocked - free resonance frequency	Hz	32 000	20 000	11 000
Thermomechanical behaviour	μm/K	0.07	0.06	0.04
Voltage range	V		-20 ... 150	
Capacitance	μF	0.55	1.1	2.2
Height	mm	18	28	48
Length	mm		10	
Width (incl. Wedges, wires)	mm		9	
Mass (excl. Wires)	g	6	12	25
Available options <sup>(m.3)</sup>			SG NM VAC TS	
Specific versions <sup>(m.4)</sup>			HT TC E	
Available interfaces <sup>(m.5)</sup>			TH FI H	

Table 4.m Characteristics of PPA M series

*m.1 With amplifier SNR of 85 dB*

*m.2 External on-axis pulling or pushing force limit. Inertial forces should be assimilated as external forces*

*m.3 Refer to §4.1.3. Standard options, page 58*

*m.4 Refer to §4.1.4. Specific versions, page 58*

*m.5 Refer to §4.1.2. Mechanical interface options, page 58*

## 4.4.2. PPA L SERIES

Some applications with PPA L are:

- Active control of vibration
- Oval piston machining
- Heavy load positioning

> [See PPA40L full datasheet](#)

> [See PPA60L full datasheet](#)

> [See PPA80L full datasheet](#)

> [See PPA120L full datasheet](#)



Fig. 4.s: PPA80L

PARAMETER	UNIT	PPA40L	PPA60L	PPA80L	PPA120L <sup>(N.1)</sup>
Nominal stroke	µm	44	67	85	130
Blocked force	N	3 500			
Stiffness	N/µm	80	52	41	27
Resolution <sup>(n.2)</sup>	nm	2.5	3.8	4.8	7.3
Force limit (0-peak) <sup>(n.3)</sup>	N	1 500			
Free - Free resonance frequency	Hz	15 000	11 000	8 700	6 300
Blocked - free resonance frequency	Hz	8 300	6 000	4 700	3 300
Thermomechanical behaviour	µm/K	0.13	0.11	0.09	0.05
Voltage range	V	-20 ... 150			
Capacitance	µF	8.8	13	18	26
Height	mm	57	77	97	140
Length	mm	24			
Width (incl. Wedges, wires)	mm	18			
Mass (excl. Wires)	g	92	120	140	190
Available options <sup>(n.4)</sup>		SG NM VAC TS			
Specific versions <sup>(n.5)</sup>		HT TC E			
Available interfaces <sup>(n.6)</sup>		TH FI H			

Table 4.n Characteristics of PPA L series

n.1 Preliminary data

n.2 With amplifier SNR of 85 dB

n.3 External on-axis pulling or pushing force limit. Inertial forces should be assimilated as external forces

n.4 Refer to §4.1.3. Standard options, page 58

n.5 Refer to §4.1.4. Specific versions, page 58

n.6 Refer to §4.1.2. Mechanical interface options, page 58

### 4.4.3. PPA XL SERIES

Some applications with PPA XL are:

- Stabilisation of heavy loads in precision machine tool
- Fretting Fatigue testing
- High Frequency Shakers

- > [See PPA40XL full datasheet](#)
- > [See PPA80XL full datasheet](#)
- > [See PPA120XL full datasheet](#)



Fig. 4.t: PPA80XL

PARAMETER	UNIT	PPA40XL	PPA80XL	PPA120XL
Nominal stroke	μm	43	90	130
Blocked force	N		7 000	
Stiffness	N/μm	160	78	54
Resolution <sup>(o.1)</sup>	nm	2.4	5.1	7.3
Force limit (0-peak) <sup>(o.2)</sup>	N	3 300	2 900	2 900
Free - Free resonance frequency	Hz	14 000	8 700	6 200
Blocked - free resonance frequency	Hz	8 000	4 600	3 300
Thermomechanical behaviour	μm/K	0.16	0.12	0.08
Voltage range	V		-20 ... 150	
Capacitance	μF	17	34	51
Height	mm	60	100	140
Length	mm		30	
Width (incl. Wedges, wires)	mm		30	
Mass (excl. Wires)	g	250	320	380
Available options <sup>(o.3)</sup>			SG NM VAC TS	
Specific versions <sup>(o.4)</sup>			HT TC E	
Available interfaces <sup>(o.5)z</sup>			TH FI H	

Table 4.o Characteristics of PPA XL series

<sup>o.1</sup> With amplifier SNR of 85 dB

<sup>o.2</sup> External on-axis pulling or pushing force limit. Inertial forces should be assimilated as external forces

<sup>o.3</sup> Refer to §4.1.3. Standard options, page 58

<sup>o.4</sup> Refer to §4.1.4. Specific versions, page 58

<sup>o.5</sup> Refer to §4.1.2. Mechanical interface options, page 58

## 4.5. CUSTOMISED PIEZO ACTUATORS

CEDRAT TECHNOLOGIES (CTEC) has developed two whole ranges of off the shelf piezo actuators: APA® and PPA.

However, if you are looking for a specific configuration you couldn't find in the previous pages, CTEC design office has the capability to study a new design and realise the new geometry.

Customisation may also consist in adding a marking, adapting the mechanical interfaces, withstanding a harsh environment or integrating an actuator in your mechanism.

Don't hesitate to contact us at [actuator@cedrat-tec.com](mailto:actuator@cedrat-tec.com) for your new development.

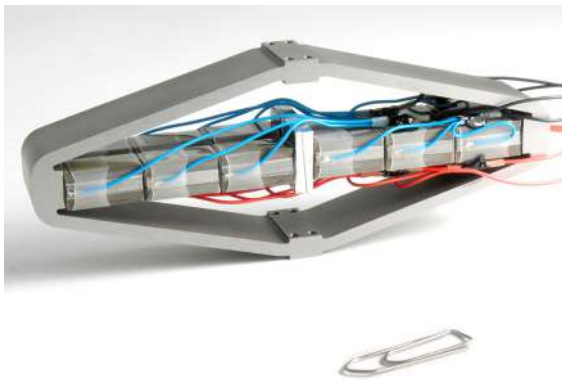

Fig. 4.u: APA500L-Twin with specific interface and wiring



Fig. 4.v: APA200MML-E

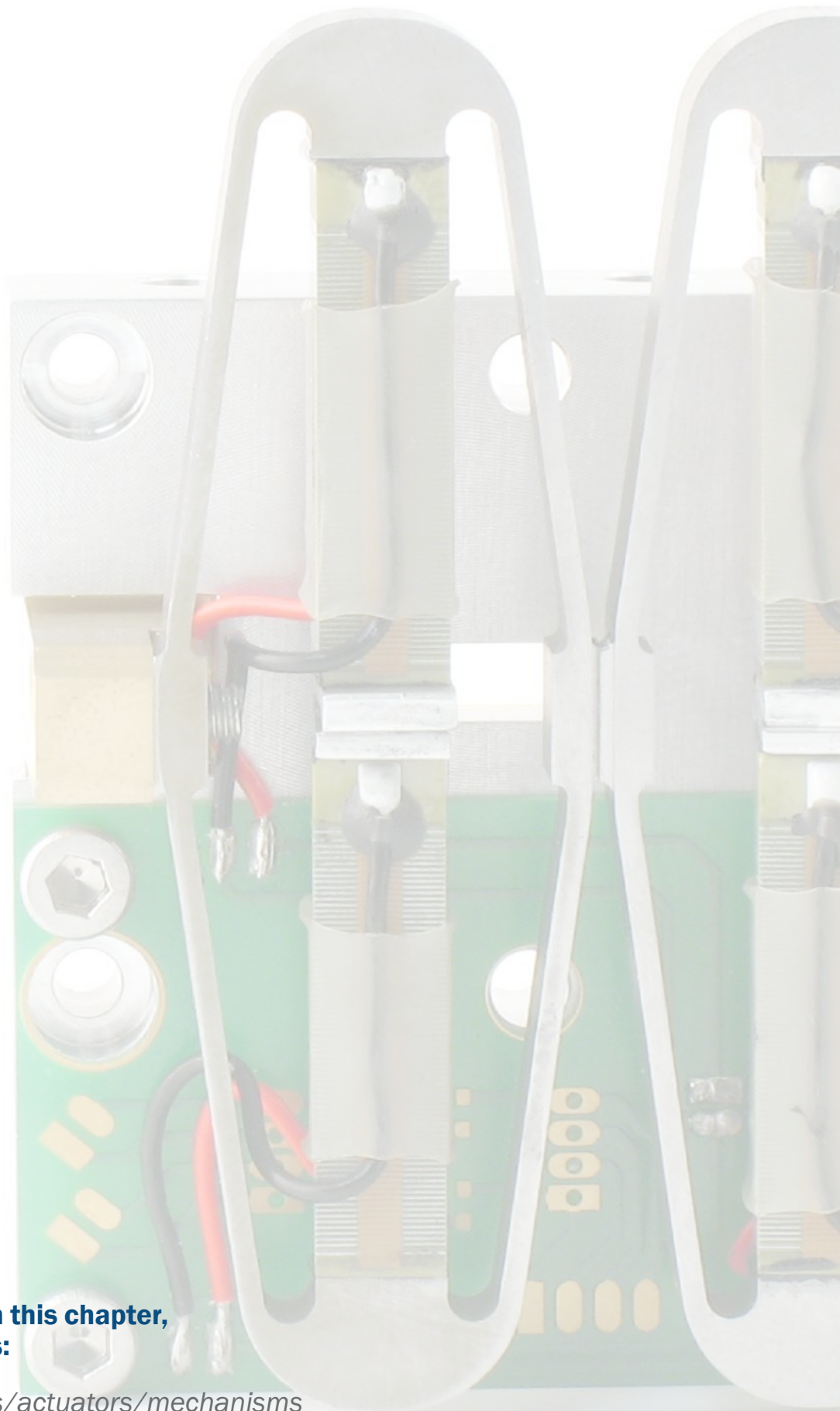

Fig. 4.w: APA500L-E-HT



Fig. 4.x: Specific APA® with stack encapsulation





**For more information on this chapter,  
please visit these pages:**

[cedrat-tec.com/products/actuators/mechanisms](http://cedrat-tec.com/products/actuators/mechanisms)

[cedrat-tec.com/technologies/actuators/piezo-mechanisms](http://cedrat-tec.com/technologies/actuators/piezo-mechanisms)

## 5. PIEZO MECHANISMS

### 5.1. SELECTION GUIDE

CEDRAT TECHNOLOGIES (CTEC) compact and dynamic actuators are used to build mechanisms, which realise advanced mechatronic functions, offer easy interfaces and can integrate optical components.

All the PPA or APA® actuators (see chapter 4, page 57) can be used to build translation stages, tilt translators or shutters. These mechanisms can integrate position sensors (see chapter 9, page 121) for closed loop control.

Different product lines are available off-the-shelf:

- **X:** single axis guided stage, with reduced out-of-plane Y and Z displacements,
- **XY:** two axis stage, with reduced out-of-plane Z displacement,
- **XYZ:** three axis stage,
- **TT:** single axis Tilt Translator,
- **DTT:** Double (two axis) Tilt Translator,
- **FPS:** Fast Piezo Shutter.

These mechanisms can be driven either by the benchtop electronics or by embedded drivers. Refer to chapter §8. *Drive Electronics & Controllers*, page 101.

Please do not hesitate to take a look at our web site, where you can download:

- The technical data sheet,
- The mechanical interface drawing,
- The 3D e-drawings file.

The mechanisms shown in this section may all be tuned to your specific requirements: dedicated interface, stroke, aperture, operating frequency, etc. Please contact us to discuss about your requirements.

## 5.2. X PIEZOELECTRIC STAGES

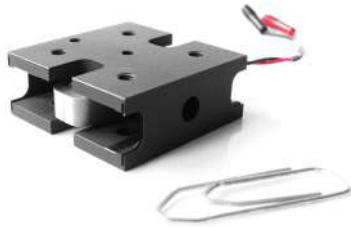

Fig. 5.a: View of the X60S stage

## 5.3. XY PIEZOELECTRIC STAGES



Fig. 5.b: View of the XY25XS stage

## 5.4. XYZ PIEZOELECTRIC STAGES



Fig. 5.c: View of the XYZ200M stage

CEDRAT TECHNOLOGIES (CTEC) single axis piezoelectric stages take advantage from the characteristics of APA® actuators and flexure guiding, in order to offer excellent compactness, robustness, bandwidth and resolution. They can be equipped with strain gauges for very fine positioning or closed loop control. Parasitic translations and rotations are very limited.

The moving frame can be custom designed (attachment points, holes...) and 2 stages can be stacked for XY motion.

As other CTEC piezoelectric stages, the two axis stages inherit the unique characteristics of APA® actuators. The stage can be equipped with Strain Gauges (SG) for very fine positioning or closed loop control. Crosstalk and parasitic rotations are very limited.

Applications include mask, lens or detector positioning, micro scanning, pixel shifting, dithering and line of sight stabilisation.

The moving frame can be custom designed (attachment points, holes...). This mechanism requires the push-pull option on the two channels of the driver. The CCBu20 controller box is often used for most of these applications.

Two axis stages can receive a third motion axis for three degrees of freedom. Performances in robustness, bandwidth and resolution inherit the unique characteristics of APA® actuators. The stage can be equipped with Strain Gauges (SG) for very fine positioning. Crosstalk and parasitic rotations are very limited.

The piezoelectric stage XYZ200M has a large stroke along the X, Y and Z axis and is able to bear loads up to 3 kg.

Applications include confocal microscopy, mask positioning and inspection.

The moving frame can be custom designed (attachment points, holes...). The mechanism requires the push-pull option on the first two channels of the driver.

PARAMETER	UNIT	X60S	X120S	XY25XS	XY200M	XY400M	XYZ200M
	-	Preliminary	Preliminary	Standard	Standard	Preliminary	Standard
Active axis	-	TX	TX	TX, TY	TX, TY	TX, TY	TX, TY, TZ
Displacement (unloaded)	µm	55	110	25	200	400	200
Stiffness	N/µm	1.2	0.26	2.5	0.59	0.14	0.59
Unloaded resonance frequency	Hz	1 840	850	3 000	580	260	380
Resolution	nm	6	11	3	20	40	20
Voltage range	V	-20 ... 150	-20 ... 150	-20 ... 150	-20 ... 150	-20 ... 150	-20 ... 150
Capacitance (per electrical port)	µF	1.6	1.6	0.50	6.3	6.3	6.3
Dimensions (X×Y×Z)	mm	30×30×12	30×30×12	50×50×19	100×100×22	100×100×27	100×100×49
Mass	g	23	23	80	450	500	540
Sensor option	-	SG	SG	SG	SG	SG	SG

Table 5.a Characteristics of piezoelectric stages



### 5.5. TILT TRANSLATOR TT



Fig. 5.d: View of the Tilt Translator TT60SM

The Tilt Translator TT is a tilt stage based on 2 APA® actuators. Two types of motion can be generated:

- A tilt RX motion when one actuator is pushing while the other is pulling.
- An optional piston Z motion (piston / translation) could be made when the two actuators are driven independently, enabling to control the position of the centre of rotation. Nevertheless this will require to adjust electrical interface and the control strategy of the TT60SM. This option is not available in standard configuration and shall be developed under customer specifications.

Applications include 1D laser pointing and micro-scanning.

The TT mechanism can be equipped with Strain Gauges (SG) for closed loop operation. If only the tilt motion is required, then only one channel is necessary, with the push-pull option on the driver.

### 5.6. DOUBLE TILT TRANSLATOR DTT



Fig. 5.e: View of the Double Tilt Translator DTT35XS

The Double Tilt Translator DTT is based on 2 pairs of APA® actuators. Two types of motion can be generated:

- A Tilt RX and/or RY motion, when one actuator is pushing while the other is pulling along one axis.
- An optional vertical Z motion (piston / translation) could be made when the two pairs of actuators are driven independently, enabling to control the position of the centre of rotation. Nevertheless this will require to adjust electrical interface and the control strategy of the DTT35XS. This option is not available in standard configuration and shall be developed under customer specifications.

Applications include 2D laser pointing, stabilisation, micro scanning, pixel shifting, and dithering.

The DTT mechanism can be equipped with Strain Gauges (SG) to operate in closed loop. The two tilt motions are driven through two amplifier channels with push-pull option.

The CCBu20 controller box is then particularly suited. The mirror support interface can be adjusted to welcome up to 50 mm diameter mirror.

PARAMETER	UNIT	TT60SM	DTT35XS	DTT60SM
Active axis	-	RX	RX, RY	RX, RY
Angular displacement	mrad (+/-)	> 22	> 5	> 10
Unloaded resonance frequency	Hz	400	2600	1750
Angular resolution	μrad	1	0.3	1
Voltage range	V	-20 ... 150	-20 ... 150	-20 ... 150
Capacitance (per electrical port)	μF	3	0.5	3
Dimensions (Ø×Z)	mm	Ø55×35	Ø45×25	Ø65×40
Mass	g	180	120	310
Sensor option	-	SG	SG	SG

Table 5.b Characteristics of Tilt Translators

## 5.7. FAST PIEZO SHUTTERS FPS200M, FPS400M & FPS900M



Fig. 5.f: View of the FPS200M (courtesy of EMBL)

The Fast Piezo Shutters (FPS) are mechanisms using two APA® actuators to open and close a slit, up to 1.1 mm in less than 10 ms. They are particularly suited to applications requiring low jitter, high repeatability or long life time.

Design of FPS series is based on APA200M, APA400M and APA900M actuators. The moving jaw can be made of tungsten to offer very high X-Ray stopping power.

FPS shutters, initially developed by CEDRAT TECHNOLOGIES (CTEC) on an initiative of Mr Cipriani from EMBL and qualified at ESRF Grenoble (France), are now used by synchrotron facilities all around the world.

The FPS family is driven and controlled by a dedicated electronic rack mounted RK42F3U-LC75B + SP75A-2 (see Table 8.j, page 109)

## 5.8. FAST AMPLIFIED PIEZO SHUTTER FAPS400M

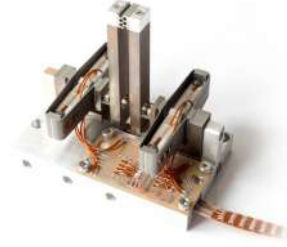

Fig. 5.g: View of the FAPS400M-SIW-SG-UHV

FAPS400M is a fast shutter solution for X-Ray beamline with large aperture capability (> 3 mm) and short response time (< 8 ms).

The FAPS400M shutter system is based on two APA400M® each one actuating a mechanical amplifier or a lever arm. At the end of each lever arm, a Tungsten (W) optical head is integrated. This head is made of an overlapping teeth pattern in order to provide with a hard stop of the beamline when the shutter is closed (Power OFF). When the power is ON, the shutter opens and offers the full aperture.

The overlap between the teeth can be adjusted with a screw. The optical heads can be removed for replacement by another optical interface. The FAPS400M can be delivered with a Strain Gauge (SG) sensor to feedback the open / close status. Vacuum (VAC) and Ultra High Vacuum (UHV) options are also available on request, the Fig. 5.g shows a FAPS400M-SIW-SG-UHV with tungsten teeth, SG sensor and UHV options. The shutter is driven by the standard SP75A-2 amplifier mounted rack that can include additional options like a strain gauge sensor conditioner board (SG75-1) and a RS-422 connector for long distance communication.

PARAMETER	UNIT	FPS200M	FPS400M	FPS900M	FAPS400M
Max. beam diameter	mm	0.30	0.70	1.1	3.0
Aperture & closing time	ms	2	4	10	8
Voltage range	V	-20 ... 150	-20 ... 150	-20 ... 150	-20 ... 150
Capacitance (per electrical port)	µF	3.2	3.2	3.2	3.2
Dimensions (X×Y×Z)	mm	60×44×21	60×44×21	60×44×23	73×54×65
Mass	g	150	150	150	150
Teeth material	-	Stainless steel / Tungsten	Stainless steel / Tungsten	Tungsten	Tungsten
Total teeth depth	mm	2.4	2.4 / 4.8	4.8	3.0
Sensors option	-	SG	SG	SG	SG <sup>(c.1)</sup>

Table 5.c Characteristics of piezo shutters

### 5.9. CUSTOMISED PIEZO MECHANISMS

The range of Commercially Off The Shelves (COTS) mechanisms shown in the previous paragraphs is indeed the tip of the iceberg in terms of sales revenue and manufacturing volume at CTEC. Usually a COTS product is hardly ready for a friendly plug and play inside the customer system for any application. More and more customer's requests are demanding in terms of integration and functionality. To answer to that reality CTEC has been demonstrating its capability to deliver customised & OEM solutions for more than 20 years.

A customised solution is the possibility for a customer to optimise the performances, the reliability and the cost of ownership for the requested product or function to be

integrated inside his system or application. This customised solution is either built from building blocks deriving from existing COTS solution or built through engineering development including design, prototyping and testing phases.

The purpose of this paragraph is to show (without being exhaustive) the diversity of the customised solutions in terms of piezo mechanisms developed and manufactured by CTEC for various industrial field. Some of these customised mechanisms have been delivered together with their controllers in order to provide the customer with a full plug & play integrated function.

Many P-FSM are also developed. Two brochures present the CTEC heritage in [Fast Steering Mirrors](#) and in [XY stages](#).

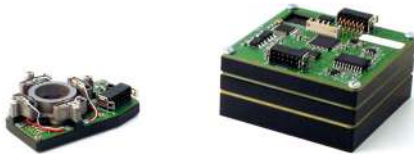

Fig. 5.i: Piezo XY stage (+/- 10 µm stroke) and its controller box for image stabilisation



Fig. 5.j: Active slits (> 700 µm aperture) for X ray beam shaper designed with SOLEIL for the SWING beamline



Fig. 5.k: Piezo FSM (+/- 1 mrad stroke) and its controller box for fine laser pointing & stabilisation

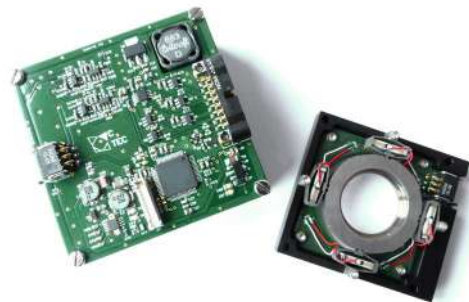

Fig. 5.l: Microscanning piezo XY stage (+/- 10 µm stroke) and its driver box for image resolution enhancement



Fig. 5.h: Piezo Fast Steering Mirror P-FSM150S for Space optical communication terminal



Fig. 5.m: Piezo activated arms (3 mm stroke) for X-ray filter holder 10 ms switching time

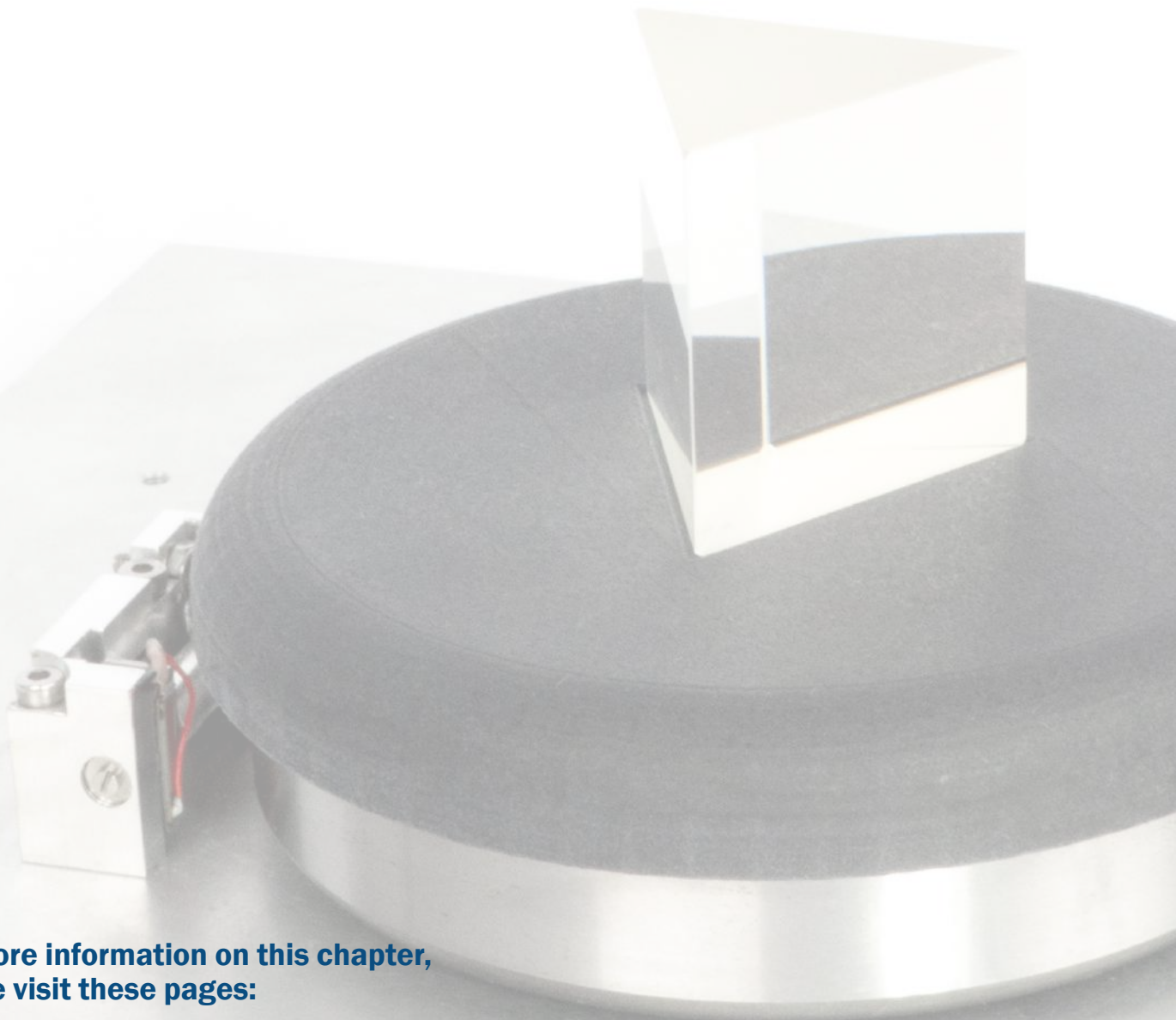

**For more information on this chapter,  
please visit these pages:**

[cedrat-tec.com/products/piezo-motors](http://cedrat-tec.com/products/piezo-motors)

[cedrat-tec.com/technologies/actuators/piezo-motors-and-electronics](http://cedrat-tec.com/technologies/actuators/piezo-motors-and-electronics)

## 6. PIEZO MOTORS AND MOTORISED STAGES

CEDRAT TECHNOLOGIES (CTEC) offers piezoelectric motors using the patented SPA technology. The SPA technology allows unique performances through the combination of the Amplified Piezoelectric Actuators (APA®) technology with the inertial motors principle.

They operate by accumulation of small steps (see §2.1.6. *Stepping Piezo Actuators SPA*, page 19). Between each step, the motor is locked into position and does not need to be powered.

Beside the long stroke mode, they can also be operated in a deformation mode for a fine adjustment. In this case, the stroke is proportional to the applied voltage, thus allowing nanometer resolution and high bandwidth.

In practice, this allows to build a brand of piezoelectric motors offering:

	LSPA	LSPS	RSPA	MSPA	FSPA
Translation	✓	✓		✓	✓
Rotation			✓	✓	
Integrated guiding		✓	✓		✓
Typical Stroke	2 - 10 mm	2 - 10 mm	Infinite	Infinite	0.1 - 10 mm
High speed	✓	✓	✓	✓	
Micro-positioning	✓	✓	✓	✓	✓
Nano-positioning	Fine mode	Fine mode	Fine mode	Fine mode	✓
Unpowered blocking force	✓	✓	✓	✓	✓

Table 6.a Piezoelectric motors

*Note: fine mode implies continuous driving voltage and is not available when motor is powered off.*

Several custom designs are presented at the end of this section. They allow multiple combinations of the various advantages of the SPA technology.

## 6.1. LINEAR STEPPING PIEZO ACTUATOR LSPA

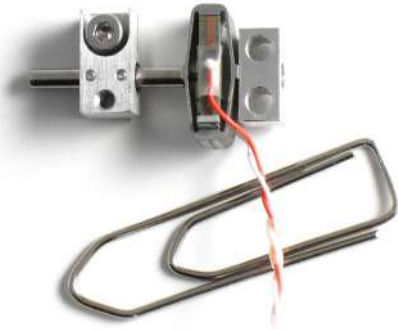

Fig. 6.a: LSPA35XS

Linear Stepping Piezoelectric Actuators (LSPA) are linear piezoelectric motors for micro/ nano positioning applications benefiting from the APA® heritage.

They contain all the needed elements for an SPA in a minimalist but efficient manner. This allows easier integration in customer mechanisms while achieving best performances.

This LSPA can be supplied with CEDRAT TECHNOLOGIES's (CTEC) standard compact driver SPC45 or with standard Linear Amplifier LA75.

Other custom Linear Stepping Piezo Actuators can be designed based on various APA®.

PARAMETER	UNIT	LSPA30UXS	LSPA35XS	LSPA40SM
		-	Preliminary	Preliminary
<b>&gt; Stepping mode</b>				
Travel range	mm	6	10	20
Nominal Speed <sup>(b.1) (b.2)</sup>	mm/s	20	10	5
Max speed <sup>(b.3)</sup>	mm/s	70	30	15
Typical step size <sup>(b.1) (b.2)</sup>	µm	5 ... 20	5 ... 30	5 ...20
<b>&gt; Fine positioning mode</b>				
Stroke <sup>(b.1) (b.3)</sup>	µm	36.0	54.0	44.0
Resolution <sup>(b.3)</sup>	nm		< 1	
Stiffness	N/µm	0.09	0.50	3.84
<b>&gt; Forces</b>				
Holding force without consumption	N	0.8	3	15
Nominal driving force <sup>(b.1) (b.2)</sup>	N	0.2	1	5
Max driving force <sup>(b.3)</sup>	N	0.3	2	10
<b>&gt; Driver</b>				
Nominal driver			SPC45	LA75B
<b>&gt; Mechanical properties</b>				
Lifetime <sup>(b.4)</sup>	cycles		> 1 000 000	
Height	mm	5.6	12.0	14.0
Width	mm	11.5	16.0	32.0
Length (in actuation direction)	mm	20.1	30.0	45.0
Mass	g	1.9	5.0	18.0

Table 6.b Characteristics of LSPA

b.1 Unloaded

b.2 With nominal driver

b.3 Custom version and driver

b.4 Unloaded, 2mm stroke, nominal speed, 50% duty-cycle

## 6.2. LINEAR STEPPING PIEZO STAGE LSPS

The Linear Stepping Piezo Stages LSPS are based on the Linear Stepping Piezo Actuator's (SPA) principle (see 2.1.6, page 19). They combine a LSPA with a position sensor and a mechanical guiding.

LSPS provide:

- A long stroke, high speed & blocking at rest
- A position information
- A micro/nano positioning resolution
- A guided motion & robustness
- Compactness & easy interfaces

LSPS stages can be driven with SPC45 driver or a linear amplifier from the LA75 family. Open and closed loop control is available. Custom stages can be designed with smaller or bigger APA®.



Fig. 6.b: LSPS35XS

PARAMETER	UNIT	LSPS35XS	LSPS40SM
		Preliminary	Preliminary
<b>&gt; Stepping mode</b>			
Travel range	mm	10	20
Nominal Speed <sup>(c.1) (c.2)</sup>	mm/s	10	5
Max speed <sup>(c.3)</sup>	mm/s	20	10
Typical step size <sup>(c.1) (c.2)</sup>	µm	5 ... 30	
<b>&gt; Fine positioning mode</b>			
Stroke <sup>(c.1) (c.3)</sup>	µm	54.0	44.0
Resolution <sup>(c.3)</sup>	nm	< 1	
Stiffness	N/µm	0.50	3.84
<b>&gt; Forces</b>			
Holding force without consumption	N	3	15
Nominal driving force <sup>(c.1) (c.2)</sup>	N	0.8	5
Max driving force <sup>(c.3)</sup>	N	2	10
<b>&gt; Driver</b>			
Nominal driver		SPC45	LA75B
<b>&gt; Mechanical properties</b>			
Lifetime <sup>(c.4)</sup>	cycles	> 1 000 000	
Height	mm	15.0	20.0
Width	mm	30.0	50.0
Length (in actuation direction)	mm	30.0	50.0
Mass	g	30.0	90.0

Table 6.c Characteristics of LSPS

c.1 Unloaded

c.2 With nominal driver

c.3 Custom version and driver

c.4 Unloaded, 2mm stroke, nominal speed, 50% duty-cycle

### 6.3. MODULAR STEPPING PIEZO ACTUATOR MSPA

Modular Stepping Piezoelectric Actuators (MSPA) are piezoelectric motors modules that can be easily integrated into already guided mechanisms to drive their mobile part (see application in chapter 6.6, page 89).

The MSPA is fixed on one part of the mechanism while a friction layer is fixed on the other part. They can accommodate limited guiding quality. This greatly eases their integration in very long stroke applications (>10 cm) and even allows their use for non-linear motion (i.e. friction track is not straight).

As with LSPA, they can also be operated in a deformation mode for a fine adjustment. In this case, the stroke is proportional to the applied voltage, thus allowing nanometre resolution and high bandwidth.

The MSPA can be supplied with CTEC's standard compact driver SPC45 or with standard Linear Amplifier LA75. Other Modular Stepping Piezoelectric Actuators can be designed using various APA®.



Fig. 6.c: MSPA35XS

This motor technology provides:

- Extreme compactness
- High speed & blocking at rest
- Nano resolution
- Linear and non-linear motion (rotating or even curved motion)
- More than 10 km displacement

PARAMETER	UNIT	MSPA30UXS	MSPA35XS	MSPA40SM
		Preliminary	Preliminary	Preliminary
<b>&gt; Stepping mode</b>				
Travel range <sup>(d.1)</sup>	mm		∞	
Nominal Speed <sup>(d.2) (d.3)</sup>	mm/s	30	10	7
Max speed <sup>(d.4)</sup>	mm/s	50	20	10
Typical step size <sup>(d.2) (d.3)</sup>	µm	5 ... 20		5 ... 25
<b>&gt; Fine positioning mode</b>				
Stroke <sup>(d.2) (d.4)</sup>	µm	36.0	54.0	45.0
Resolution <sup>(d.4)</sup>	nm		< 1	
Stiffness	N/µm	0.09	0.50	3.80
<b>&gt; Forces</b>				
Holding force without consumption	N	0.8	3	10
Nominal driving force <sup>(d.2) (d.3)</sup>	N	0.2	0.5	1.75
Max driving force <sup>(d.4)</sup>	N	0.3	1	2.5
<b>&gt; Driver</b>				
Nominal driver		SPC45		LA75B+UC45
<b>&gt; Mechanical properties</b>				
Lifetime <sup>(d.5)</sup>	m	> 2 000		
Height of module	mm	7.0	10	20.0
Width of module	mm	15.0	20	20.0
Length (in actuation direction)	mm	20.0	30.0	50.0
Mass	g	12.0	20.0	40.0
Max friction trip run-out	µm	±50	±100	

Table 6.d Characteristics of MSPA

d.1 Limited by moving part

d.2 Unloaded

d.3 With nominal driver

d.4 Custom version and driver

d.5 Unloaded, nominal speed, 50% duty-cycle, ambient conditions



## 6.4. ROTARY STEPPING PIEZO ACTUATORS RSPA

Rotary Stepping Piezoelectric Actuators (RSPA) are rotary piezoelectric motors with 360° revolutions. They operate by accumulation of small steps (see §2.1.6. *Stepping Piezo Actuators SPA*, page 19).

This motor technology provides:

- Extreme compactness
- High rotational speed & blocking at rest
- Nano resolution
- More than 1 million cycles

The motor is locked in position when unpowered. RSPA can be supplied with CEDRAT TECHNOLOGIES's (CTEC) standard compact drivers SPC45 or with standard Linear Amplifier LA75. Custom Stepping Piezo Actuators can be designed based on various APA®.



Fig. 6.d: RSPA30uXS with customised output axis

PARAMETER	UNIT	RSPA30UXS	RSPA35XS
		Preliminary	Preliminary
<b>&gt; Stepping mode</b>			
Travel range	rad	∞	
Nominal Speed <sup>(e.1)</sup> <sup>(e.2)</sup>	rpm	20	10
Max speed <sup>(e.3)</sup>	rpm	50	22
Typical step size <sup>(e.1)</sup> <sup>(e.2)</sup>	mrاد	0.2 ... 2.5	0.2 ... 3
<b>&gt; Fine positioning mode</b>			
Stroke <sup>(e.1)</sup> <sup>(e.3)</sup>	mrاد	4	3.9
Resolution <sup>(e.3)</sup>	μrad	< 0.1	
<b>&gt; Torques</b>			
Holding torque without consumption	mNm	2.8	10
Nominal driving torque <sup>(e.1)</sup> <sup>(e.2)</sup>	mNm	0.7	2.5
Max driving torque <sup>(e.3)</sup>	mNm	1	3.5
<b>&gt; Driver</b>			
Nominal driver		SPC45	
<b>&gt; Mechanical properties</b>			
Lifetime <sup>(e.4)</sup>	cycles	> 1 000 000	
Height	mm	10.0	18.0
Diameter	mm	12.0	20.0
Mass	g	3.0	8.0

Table 6.e Characteristics of RSPA

e.1 Unloaded

e.2 With nominal driver

e.3 Custom version and driver

e.4 Unloaded, 2mm stroke, nominal speed, 50% duty-cycle

## 6.5. FINE STEPPING PIEZO ACTUATOR FSPA



Fig. 6.e: FSPA35XS

Fine Stepping Piezo Actuator (FSPA) is a patented actuator that combines SPA technology with mechanical reduction. This allows to achieve very small step sizes even down to 10 nm. Typical max speed for FSPA is 200  $\mu\text{m/s}$ .

Another major advantage of FSPA is its ability to maintain its position, while unpowered, even when very large outer forces or acceleration are applied.

The main application for this actuator is to finely tune the position of a payload and hold this position afterward even though environmental conditions may get real bad such as vibration and shocks during off-road transportation, space launch or aircraft landing...

PARAMETER	UNIT	FSPA35XS
Status		Preliminary
<b>&gt; Forces</b>		
Actuation force <sup>(f.1)</sup>	N	20 /100
Holding force <sup>(f.2)</sup>	N	> 200
<b>&gt; Stepping mode</b>		
Travel range	mm	5
Typical min step size <sup>(f.3)</sup>	nm	< 100
Typical max speed <sup>(f.4)</sup>	$\mu\text{m/s}$	200
<b>&gt; Driver</b>		
Nominal driver		SPC45
<b>&gt; Mechanical properties</b>		
Typical lifetime <sup>(f.5)</sup>	Cycles	100
Dimensions	mm	Diam 40 x 62
Total mass	g	160

Table 6.f Characteristics of FSPA

*f.1 Max actuation stall force, no more displacement, depending on the max output peak current of the driver (20N @ 150 mA peak with SPC45 / 100N @ 1.2 A with High power amplifier)*

*f.2 Unpowered*

*f.3 Minimum Step size in coarse positioning mode for 50V output voltage step with SPC45*

*f.4 Maximum speed in coarse positioning mode for 100V output voltage step with SPC45*

*f.5 1 cycle is over 2 mm stroke at max speed , for higher number than 100 cycles please contact CTEC*

## 6.6. CUSTOMISED PIEZO MOTOR MECHANISMS

### 6.6.1. ROTARY STAGE

The rotary stage is a demonstrator of an MSPA integration (see Fig. 6.f). An MSPA35XS is simply pressed against a common ball bearing. This basic Ø80 mm mechanism achieves 2 tr/min and a 0.2 mrad a resolution.

### 6.6.2. LONG STROKE LINEAR STAGE

This linear stage is a demonstrator of an MSPA combined with a basic linear ball bearing guiding. The MSPA has been attached to the moving stage and is then able to travel on more than 100 mm with 20 mm/s. A 5 µm stepping resolution can be achieved.

The customised MSPS35XS stage shown in (see Fig. 6.g) is based on fixed MSPA35XS driving a linear guided top plate in motion. The MSPS35XS stage aims at adjusting the focus of a lens payload fixed on the top plate over 17 mm linear stroke in a compact size (~76×56×23 mm) and low mass (~130 grams). The max speed is 8 mm/s and the driving force is greater than 1 N with standard SPC45 controller.

### 6.6.3. LONG STROKE CURVED STAGE

In this application, the capability of the MSPA achieve curved motion is demonstrated (Fig. 6.i). The MSPA is driving a flat turning track on 90°. Thanks to the robustness of the MSPA technology, the radial speed variation has no significant impact on the driving characteristics.



Fig. 6.f: MSPA rotary demonstrator



Fig. 6.g: MSPA long stroke demonstrator



Fig. 6.h: MSPS35XS linear stage



Fig. 6.i: MSPA curved track demonstrator



Fig. 6.j: 3 axis closed loop mechanism



Fig. 6.k: FSPA EM for IASI-NG

### 6.6.4. 3 AXIS CLOSED LOOP MECHANISM

Thanks to their flexibility, MSPA can be combined to achieve direct multi-degrees of freedom movement. In the following mechanism (see Fig. 6.j), 3 MSPA are joined to achieve simultaneous Rx, Ry, Tz movement.

In that sense the mechanism is similar to a standard DTT35XS. However, using the MSPA35XS stroke capability, the achievable stroke is a hundred times larger ( $R_x=R_y=+/-2.5^\circ$ ,  $T_z=+/-2$  mm). Simultaneously, extreme pointing resolution remains available using the fine movement mode.

Additionally, the mechanism includes position sensors to monitor the 3 axis instantaneous position. Closed loop control has then been demonstrated both for speed or position control.

### 6.6.5. SPACE FSPA

Derived from the FSPA motor, a customised space compliant actuator is designed and tested for the IASI-NG space project (Fig. 6.k). This actuator includes complete cold redundancy. All major components are doubled, including the FSPA derived actuators.

The motor provides 150 µm stroke and is targeting a better than 50 nm position stability when unpowered.

Fast positioning and nanometric position sensing are also included though the addition of 2 PPA actuators as well as 2 ECS sensors.

Due to the space dedication of this actuator, all design and testing activities comply with the ECS standard.

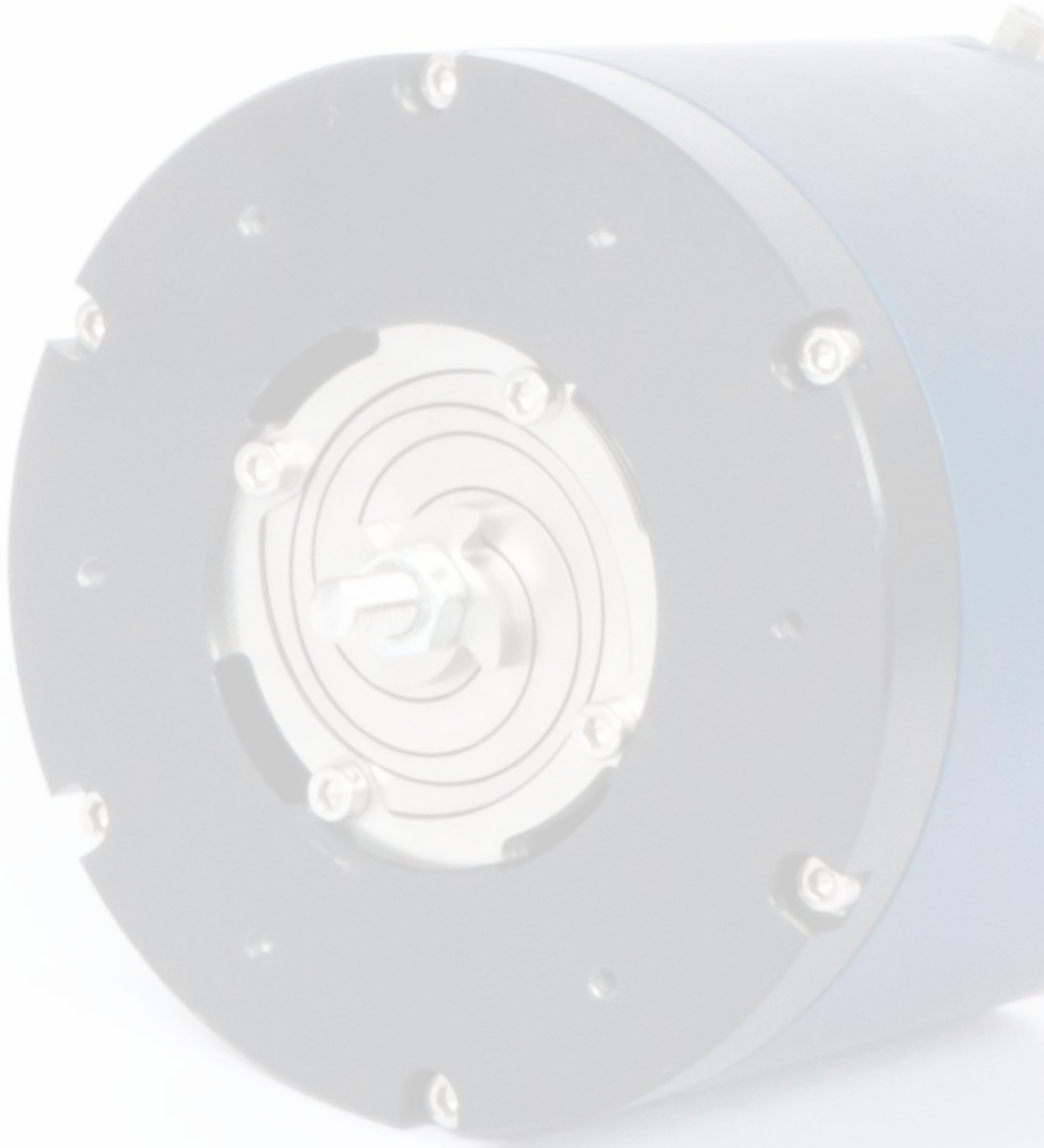

**For more information on this chapter,  
please visit these pages:**

[cedrat-tec.com/products/magnetic-actuators](https://cedrat-tec.com/products/magnetic-actuators)

[cedrat-tec.com/technologies/actuators/magnetic-actuators-motors](https://cedrat-tec.com/technologies/actuators/magnetic-actuators-motors)

## 7. MAGNETIC ACTUATORS

CEDRAT TECHNOLOGIES (CTEC) has a large heritage in magnetic actuators, sensors and driving electronics. It has been designing, optimising and manufacturing electro-magnetic actuators such as moving iron, voice coil, moving magnet and electromagnet actuators for its customers for more than 20 years.

The MICA™ and BLMM actuators series are standard products. They are powerful, compact, dynamic and precise actuators.

Beyond these standard products, CTEC also offers a complete range of engineering services from specifications to custom products: Feasibility, design, optimisation, prototyping, testing, manufacturing and training.

## 7.1. MOVING IRON CONTROLLABLE ACTUATOR MICA™

Moving Iron Controllable Actuators (MICA™) are patented magnetic actuators from CEDRAT TECHNOLOGIES (CTEC). They provide a controllable high force along the stroke.

It is particularly suited for dynamic applications requiring long strokes. MICA™ actuators provide:

- **Large force in a compact design.**
- **High dynamics**, meaning high acceleration (see Fig. 7.b).
- **High reliability.**
- **Maintenance free flexure bearing** available
- **High resolution:** MICA™ actuators have a continuous displacement, enabling to reach high resolution. For extreme resolution, frictionless guiding should be chosen (Fig. 7.a).
- **Low self-heating:** MICA™ actuators' configuration natively helps in thermal dissipating and of course integrates a temperature sensor to monitor the coil heating. Performances can still be increased thanks to cooling

capabilities either passively (heater, thermal interface) or actively (fan, forced air).

Other capabilities are available as options:

- **Frictionless long life flexure bearings:** Efficient flexure bearing design allows to achieve aerospace and military standard of 20 000 hours at 50 Hz i.e. more than three billions cycles full stroke in continuous operation, friction free (linear behaviour) and tunable natural frequency. Flexure bearings improve the output power capability at resonance frequency (see §2.2.9. *Resonant flexure bearing actuators*, page 34).
- **Incremental position sensor:** every MICA™ can integrate 15 µm resolution sensor. Higher performances (less than 1 µm) can be achieved upon request.
- **Cooling interfaces:** the unique design of MICA™ allows to easily plug efficient cooling systems when operating and environmental conditions lead to thermal issue management.



Fig. 7.a: MICA300CM-FB with flexure bearing option

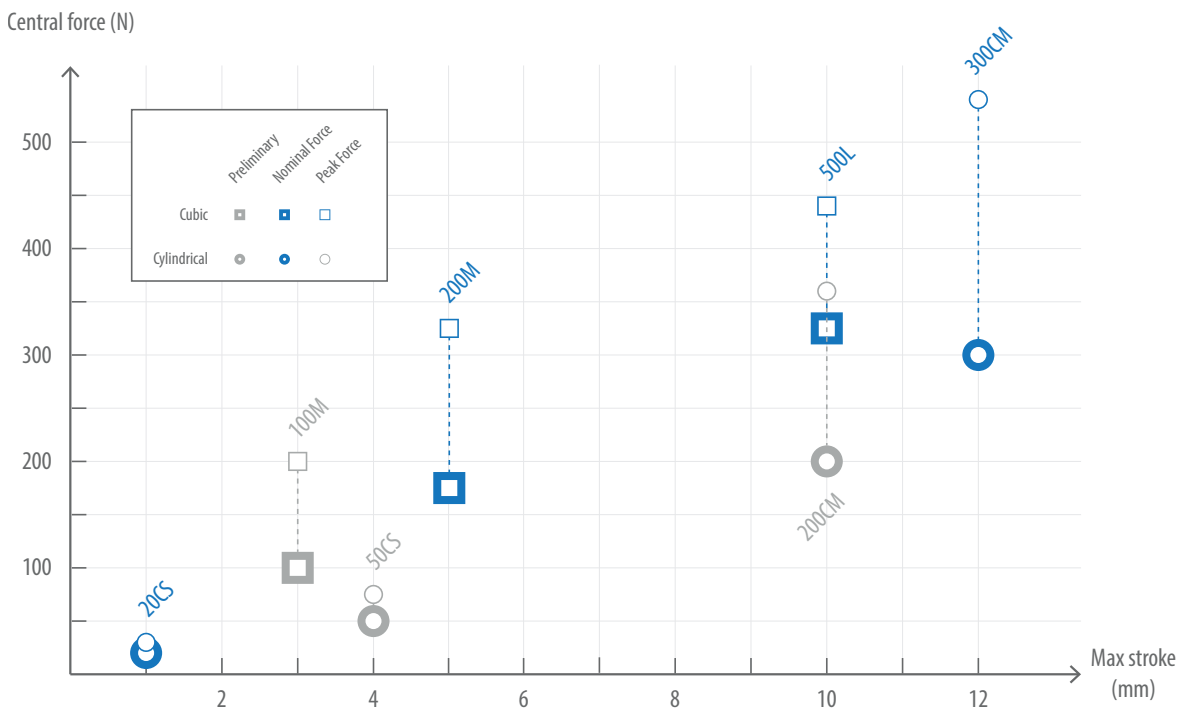

Fig. 7.b: MICA™ series overview Force / Stroke

- **Accessories:** MICA™ design is also compatible with standard mechanical accessories: brackets, ball joint, supports...

The MICA™ actuators may have a stroke larger than 10 mm, and forces range from 20 N to 550 N.

They are versatile actuators: precise at low speed, efficient at resonance and providing high force above resonance frequency. All those magnetic actuators can be driven with our drive electronics (see for example our CSA96 switching amplifier).

MICA™ remains also compatible with off the shelf power amplifier existing on the market.

To model the behaviour of magnetic actuators, CTEC provides COMMACT™ software. It is a dedicated tool that draws MICA™ performances (see paragraph §2.2. Tutorial on magnetic actuators, page 27). This tool allows direct exploitable results for the user. It is available upon request.

Since every application is specific, CTEC has created two types of shape factor for these MICA™ actuators: **Cubic** or **Cylindrical** shape.

Actuators are also named with respect to their size: **S** for small, **M** for medium and **L** for large.

**Nominal performances** are given force continuous operation without any cooling feature.

**Peak performances** are achieved for a duration of 10 seconds at 25 °C (reaching max 155 °C in the coil winding).

**Available stroke** is defined as the possible mechanical travel between end-stops.

With **dedicated cooling**, the peak force becomes achievable in continuous operation.

MICA™ can be customised and tuned to achieve higher stroke with compromise on the force. For example MICA300CM can extend its stroke from 12 to 20mm when reducing nominal force

from 300 to 150 N (see Fig. 7.c).

See characteristics of cubic and cylindrical shapes MICA™ next page, in Table 7.a and Table 7.b

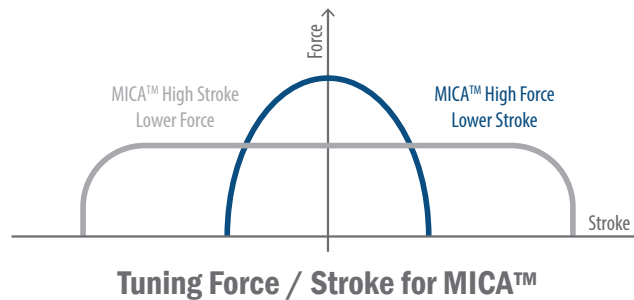

Fig. 7.c: Tuning Force / Stroke for MICA™ C



Fig. 7.d: MICA500L



Fig. 7.e: MICA200M



Fig. 7.f: MICA20CS



Fig. 7.g: MICA300CM (no option)

PARAMETER	UNIT	MICA100M	MICA200M	MICA500L
	-	Preliminary	Standard	Standard
<b>&gt; Specifications</b>				
Nominal Force	N	100	175	330
Nominal Force constant	N/A	7	12	22
Peak Force	N	200	320	440
Peak Force constant	N/A	6	9	17
Stroke (peak to peak)	mm	3	5	10
Nominal Force @ 50% stroke	N	90	160	230
Nominal Force @ 80% stroke	N	75	130	185
DC Resistance	Ohm	0.2	0.2	0.6
Inductance	mH	4	6	90
Max Acceleration	g	170	160	50
Standard linear bearing type	-	Flexure	Flexure	Flexure
Weight	kg	2.0	3.2	8.0
Moving mass	kg	0.12	0.21	0.85
Cross section size	mm	80×80	120×80	150×140
Length	mm	115	115	160
<b>&gt; Options</b>				
Sensor	-	✓	✓	✓
Flexure bearing <sup>(a.1)</sup>	-	✓	✓	✓
Cooling	-			✓ <sup>(a.1)</sup>

Table 7.a Characteristics of cubic shape MICA™ actuators

PARAMETERS	UNIT	MICA20CS	MICA50CS	MICA200CM	MICA300CM
	-	Standard	Preliminary	Preliminary	Standard
<b>&gt; Specifications</b>					
Nominal Force	N	20	50	200	300
Nominal Force constant	N/A	40	10	24	33
Peak Force	N	30	80	360	540
Peak Force constant	N/A	30	9	20	30
Stroke (peak to peak)	mm	1	4	10	12
Nominal Force @ 50% stroke	N	14	35	150	230
Nominal Force @ 80% stroke	N	7	18	70	110
DC Resistance	Ohm	13.5	0.3	0.3	0.3
Inductance	mH	80	3	8	12
Max Acceleration	g	50	55	120	95
Standard linear bearing type	-	Flexure	Bushing	Bushing	Bushing
Weight	kg	0.35	1.2	1.9	3.2
Moving mass	kg	0.14	0.15	0.30	0.58
Diameter	mm	40	70	90	100
Length	mm	60	70	90	120
<b>&gt; Options</b>					
Sensor	-	✓ <sup>(b.1)</sup>	✓	✓	✓
Flexure bearing	-	✓ <sup>(b.2)</sup>	✓	✓	✓
Cooling	-		✓	✓	✓

Table 7.b Characteristics of cylindrical shape MICA™ actuators

a.1 Standard configuration, not optional

b.1 Force sensor

b.2 Standard configuration, not optional



## 7.2. BISTABLE LINEAR MOVING MAGNET BLMM

BLMM stands for Bistable Linear Moving Magnet. Those magnetic actuators are based on a permanent magnet moving between two opposite electromagnets.

The main advantage of the BLMM is its holding force without dissipation when not powered. This makes BLMM perfect for applications such as latches devices, locking devices, electro valves, contactors, etc...

BLMM Advantages:

- **Holding force at rest**
- **Fast commutation**
- Small size
- Simple current pulse

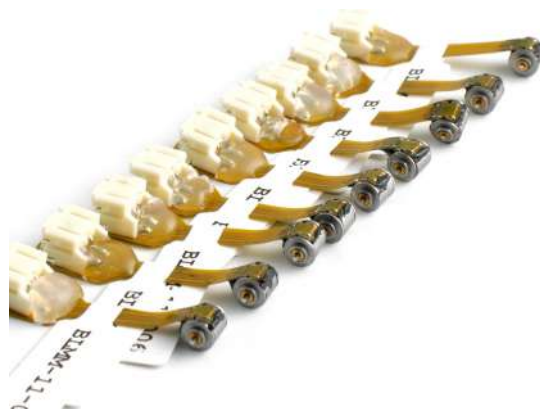

Fig. 7.i: BLMM1XS, production batch



Fig. 7.h: BLMM200M with customised interface

PARAMETER	UNIT	BLMM1XS	BLMM50S	BLMM200M
	-	Standard	Preliminary	Standard
Stroke	mm	> 0.5	3	7
Holding force at rest (Fh)	N	0.08	50	200
Commutation time	ms	< 1.7	< 10	<90
Nominal commutation current I	A	+/- 1.2	+/- 6	+/- 15
Total Mass	g	1.1	50	1 200
Actuator diameter size	mm	< 6	25	80
Height actuator (without shaft)	mm	6.8	20	91
Type of shaft	-	All through shaft		
Diameter Mobile shaft	mm	0.8	3	8

Table 7.c Characteristics of BLMM

### 7.3. TUNABLE PROOF MASS ACTUATORS

Proof Mass Actuators are inertial vibration generators, mostly intended for vibration cancellation, vibration damping or shaking applications. The operating principle of such actuators is based on the use of a resonant Flexure Bearing Actuators, attached to a counter mass, that can be tuned according to specific resonance frequency requirements. In order to do so, both counter mass, and flexure bearing assemblies, can be optimised on demand for each custom application.

Cedrat Technologies proposes customizable Proof Mass Actuators, based on the standard MICA300CM and MICA20CS Flexure Bearing Actuators, with tunable counter mass, respectively optimised for operation with CSA96 and CSAu10 drive electronics. These devices find applications in machine tools and in instruments.



Fig. 7.i: MICA20CS Proof Mass actuator



Fig. 7.j: MICA300CM Proof Mass actuator

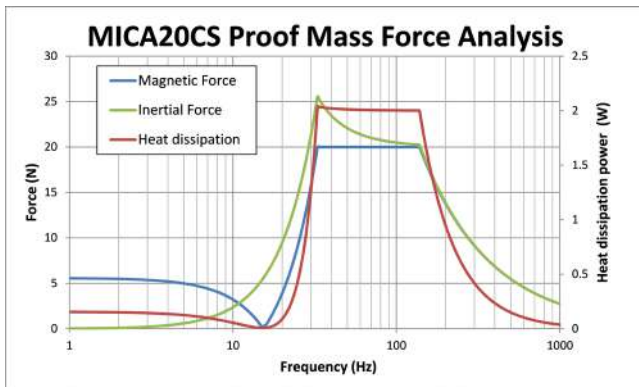

Fig. 7.m: MICA20CS Proof Mass actuator inertial force and heat dissipation analysis

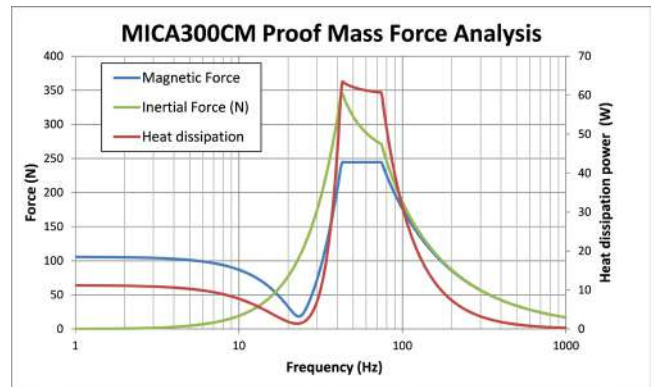

Fig. 7.k: MICA300CM Proof Mass actuator inertial force and heat dissipation analysis

PARAMETER	UNIT	MICA20CS PROOF MASS	MICA300CM PROOF MASS
Tunable moving mass	kg	0.14 - 0.60	0.60 - 1.50
Tunable resonance frequency <sup>(d.1)</sup>	Hz	12 - 25	18 - 30
Maximum inertial force range <sup>(d.2)</sup>	N	20 - 25	250 - 350

Table 7.d Characteristics of MICA™ Proof Mass

d.1 Achieved by tuning only the moving mass. Other resonance frequencies can be achieved with custom flexure bearing configurations.

d.2 In the vicinity of resonance frequency and above

## 7.4. SPECIFIC MAGNETIC ACTUATORS

Beyond standard linear magnetic actuators shown in the previous sections, CEDRAT TECHNOLOGIES (CTEC) develops customised solutions to address customer specific requirements in terms of performances and environment. These customised solutions are either built by modification of existing COTS solution or built through engineering development including design, prototyping and testing phases. The purpose of this section is to give some examples of specific realisations.

### 7.4.1. MOVING COIL ACTUATORS MCA

Specific linear voice coil actuators have been developed and space qualified for MTG (Meteosat Third Generation) (see Fig. 7.n and Fig. 7.k).

- Force homogeneity < 2 % all along the stroke
- Redundant architecture
- Space qualified MCA (Cleanliness, Vibration, Thermal)
- Stroke = 24 mm
- Force constant = 12 N/A

### 7.4.2. EXTRA FLAT MICA™ STAGES

MICA™ technology allows for making X stage (see Fig. 7.l) as well as XY stage (see Fig. 7.m).

The flat MICA™ X stage offers the following features :

- Integrated proof mass
- Tangential motion (along long dimension)
- Highly dynamic
- Peak force = 600 N
- Force constant = 30 N/A
- Stroke = 6 mm

The XY stage offers a 2D continuous motion in X and Y directions, perpendicularly to the Z axis. A central hole can welcome an optic. Typical application is active stabilisation and antiblur. Key performances are :

- Peak force = 2 N
- Stroke = 2 mm



Fig. 7.n: MCA stator



Fig. 7.o: MCA moving part



Fig. 7.p: Flat MICA™ X stage



Fig. 7.q: XY MICA™ stage

### 7.4.3. SPECIFIC ELECTRO-MAGNET ACTUATOR EMA



Fig. 7.r: Electromagnets production batch

Electro-Magnet Actuators (EMA) are suitable when design-to-cost is required. Such an actuator type is deemed relevant when medium to large production is considered. In addition they provide high force in a compact volume. CEDRAT TECHNOLOGIES has the necessary knowledge, equipment and experience to provide custom design as well as production batches.

Fig. 7.r shows an example of production batch based on CTEC custom design for the automotive sector. These specific EMA offer the following performances:

- Force = 30 N
- Stroke = 2 mm
- Response time < 10 ms

### 7.4.4. SPECIFIC MOVING IRON ACTUATOR



Fig. 7.s: Specific moving iron actuator

Specific moving iron actuators are necessary for controllable dynamic operations. The special design showed on Fig. 7.s illustrates a moving iron actuator equipped with flexure bearings for long life time purposes. Elsewhere, this actuator works by pair, in a push pull mode, in order to provide high force level at resonance frequency. The customisation includes an embedded drive electronic, one displacement sensor and a closed loop control.

This specific moving iron actuator offers the following performances:

- Force = 80 N
- Stroke = 8 mm
- Bandwidth >100 Hz

### 7.4.5. ASYNCHRONOUS LINEAR MOTOR

Whereas previous specific actuators are limited in stroke, in some cases, custom actuators requires unlimited displacement range to convey one payload in a defined pattern. The conventional solution involves one rotating motor and a transmission belt. The main drawback of this solution remains on the maintenance cost. That is the reason why CTEC proposes a custom belt free conveyor in a contactless linear motor. The custom design showed on Fig. 7.t allows multiple carriage synchronization by speed control

Main performances of this dedicated asynchronous motor are the following:

- Force = 20 N
- Stroke = only limited by the number of components.
- Controlled Speed = 0.4 m/s



Fig. 7.t: Specific asynchronous linear motor

### 7.4.6. MAGNETIC FAST STEERING MIRROR M-FSM

To offer an alternative to piezoelectric DTT for Fast Steering Mirrors (FSM), CTEC develops also Magnetic-actuators-based FSM (M-FSM). M-FSM realises optical pointing with larger motion than piezo DTT while keeping high resolution and large bandwidth. Typical applications are Free Space Optic (FSO) communication links, laser guide star, laser designators...

For example, a recent development has led to a M-FSM (Fig. 7.u) producing large bandwidth Angular Strokes  $R_x R_y > +/- 2^\circ$ . The M-FSM mechanism volume contains the mirror, the actuators, the guiding and the ECS position sensors. High performance MICA™ allows to perform the dynamic strokes with low heating. Frictionless flexure bearings allow to achieve both high resolution and infinite life time. Associated electronics for sensing, driving and controlling are the ECS45 and MCSA480. These electronic offer both open & closed loop control modes with high dynamic performances thanks to 10 A / 48 V high current / voltage limits and advanced controlled laws.

Key performances are :

- Angular strokes  $R_x R_y = 70$  mrad
- Full stroke bandwidth > 200 Hz
- Mechanism Volume =  $\varnothing 62$  mm  $\times$  H56 mm

Other M-FSM are developed. Please consult dedicated brochure and web page



Fig. 7.u: Magnetic Fast Steering Mirror M-FSM62 (with D31 mm mirror)



Fig. 7.v: Magnetic Fast Steering Mirror M-FSM45 (with D17 mm mirror)



**For more information on this chapter,  
please visit these pages:**

[cedrat-tec.com/products/piezo-controllers](http://cedrat-tec.com/products/piezo-controllers)

[cedrat-tec.com/products/magnetic-controllers](http://cedrat-tec.com/products/magnetic-controllers)

[cedrat-tec.com/products/piezo-motor-controller](http://cedrat-tec.com/products/piezo-motor-controller)

## 8. DRIVE ELECTRONICS & CONTROLLERS

CEDRAT TECHNOLOGIES (CTEC) offers a range of electronic amplifiers and controllers to drive both in open and closed loop in an optimal manner its own range of piezo actuators, magnetic actuators and piezo motors. These amplifiers & controllers are available either integrated in powered 19" sub-rack (mainly for laboratory & factory use) or integrated in DC powered OEM board & box (mainly for embedded applications).

The range of powered sub-rack mounted & OEM series are further described in the following paragraphs.

## 8.1. AMPLIFIERS & CONTROLLERS FOR PIEZO ACTUATORS

### 8.1.1. OEM SERIES



Fig. 8.a: CAu10

The Compact Amplifier CAu10 (Fig. 8.a) and Compact Controller Board CCBu20 (Fig. 8.b) are OEM amplifiers and controllers available off the shelves.

The CAu10 is a miniature two-channels amplifier board with both analog and digital (SPI communication) inputs. It is used for driving piezo actuators in open loop, which is able to deliver 5 mA per channel and requires a DC voltage supply of 5 to 12 V.

PARAMETER	UNIT	CAU10 <sup>(A.1)</sup>
<b>&gt; General</b>		
Function		Embedded Driver for piezoelectric actuators
Number of channels		2 + Push Pull
<b>&gt; Input</b>		
Analogue Control Input voltage	V	0 ... +3.3
Digital Input voltage (SPI protocol)	V	3,3
<b>&gt; Output</b>		
Typical output voltage	V	+5 ... +150
Continuous output current <sup>(a.2)</sup>	mA	±5
<b>&gt; Power amplifier</b>		
Peak output power <sup>(a.3)</sup>	VA	1
<b>&gt; Gain</b>		
Gain	V/V	45
<b>&gt; Dynamic performance</b>		
Small signal bandwidth (-3dB) <sup>(a.4)</sup>	kHz	2
<b>&gt; Noise performance</b>		
Signal to Noise Ratio <sup>(a.5)</sup>	dB	70
<b>&gt; Power Supply</b>		
Main Power supply	VDC	5 ... 12
<b>&gt; Options</b>		
Connector interface option for CAu10 2 channels		To connect two actuators

Table 8.a Characteristics of CAu10

a.1 Guaranteed in labs environment

a.2 Internally limited

a.3 AC+DC apparent power, sine signal

a.4 Unloaded

a.5 Computed as RMS output signal/RMS output Noise floor



The CCBu20 and CCBu40 are 2-channel push-pull controller boxes, designed for driving the XY stages & Fast Steering Mirrors piezo mechanisms developed by CEDRAT TECHNOLOGIES (CTEC).

They can be operated in open loop or closed loop configurations, with up to 2 axes.



Fig. 8.b: CCBu20 and CCBu40

PARAMETER	UNIT	CCBu20	CCBu40
<b>&gt; General</b>			
Function		All-in-one piezo-driver and controller	
Number of control channels		2	
Digital communication		RS422	
Graphical User Interface		CTEC HDPM	
<b>&gt; Digital control</b>			
Control strategy		Tunable PID + Stabilizing filters	
Sampling rate	kSps	20	50
Digital resolution	bits	16	
<b>&gt; Analog inputs</b>			
Number of analog inputs		2	
Analog inputs Voltage range	V	-10 ... +10	
<b>&gt; Strain gages (SG) conditioner</b>			
Number of channels		2	
Output voltage range	V	-10 ... +10	
<b>&gt; Piezo driver</b>			
Number of channels		2	
Nominal output voltage range	V	-20 ... +150	
Peak output current	A	0,2	0.5
RMS output current <sup>(b.1)</sup>	Arms	0,035	0.35
<b>&gt; Power supply</b>			
Recommended supply voltage	Vdc	+28	
<b>&gt; Miscellaneous</b>			
Mass	kg	0.25	0.8
Dimensions	mm <sup>3</sup>	91 × 77 × 35.2	160 x 170 x 36
Operating temperature range <sup>(b.2)</sup>	°C	-40 ... +70	
<b>&gt; External sensor option <sup>(b.3)</sup></b>			
Functionality		Connection of an external analog sensor on the CCBu20	
Input voltage range	V	-10 ... +10	

Table 8.b Characteristics of CCBu20 & CCBu40

b.1 At +28 Vdc supply and @70 °C. Lower output current has to be considered for lower supply voltages

b.2 Additional heatsink might be required

b.3 Applies to both channels; replaces the integrated SG conditioner

## 8.1.2. POWERED RACK MOUNTED SERIES

The powered mounted series consists of a number of powered 19" sub-rack reference. A powered rack or case includes as standard an AC/DC (either linear or switching) converter board to convert the power from the main electrical power and to deliver it to the other functional boards (amplifier, conditioner & controller) presented in the next paragraphs. The powered 19" sub-rack can be inserted in an industrial cabinet.

The powered bench top (Fig. 8.c next page) and the powered 19" sub-rack (Fig. 8.d next page) allow for various combinations of amplifier, sensor conditioner and controller boards with single or multi channels as well as output power options.

The Table 8.c shows the different possibilities to build your configuration.

PARAMETER	RK42F3U -LC75B	RK42F4U -LC75C	RK84F4U -1LC75B	RK84F4U -1LC75C	RK84F4U -2LC75C	RK84F4U -3LC75C	RK84F4U -1SC75D	RK84F4U -2SC75D
<b>&gt; Application</b>								
AC-DC converter topology	Linear						Switching converter	
Max. No. of hosted amplifiers & conditioner boards	2 in total (c.1)	1 of each	6 in total (c.1)	6 in total (c.1)	2 of each (c.1)	3 of each (c.1)	1 of each	2 of each
Max supplied current	0.75 A	2.55 A	0.75 A	2.55 A	5.1 A	7.65 A	20 A	2 x 20 A
<b>&gt; Power supply</b>								
Supply voltage	110/240 VAC							
Supply frequency	50-60 Hz							
<b>&gt; Protections</b>								
Protection type <sup>(c.2)</sup>	T., OC., HBD.	T., OC., HBD.	T., OC., HBD.	T., OC., HBD.	T., OC., HBD.	T., OC., HBD.	T., OC., OV.	T., OC., OV. <sup>(c.3)</sup>
<b>&gt; Board compatibility</b>								
LA75A - Up to 3 channels	✓		✓	✓				
LA75B - Up to 2 channels	✓		✓	✓				
LA75C - 1 channel		✓		✓	✓	✓		
SA75A - Up to 2 channels							✓	✓ (c.4)
SA75B - Up to 2 channels							✓	✓ (c.4)
SA75D - 1 channel							✓	✓
SG75 - Up to 3 channels	✓	✓ (c.4)	✓	✓	✓	✓	✓	✓
ECS75 - Up to 3 channels	✓	✓ (c.4)	✓	✓	✓	✓	✓	✓

Table 8.c Characteristics of powered racks

c.1 Sum should not exceed the max supplied current

c.2 T: Thermal; OC: Overcurrent; HBD: Hosted board default; OV: Overvoltage

c.3 Each SC75 board

c.4 Only 1 channel

The 8 powered rack or case items available off the shelves are listed below:

- **RK42F3U-LC75B**  
Powered benchtop case for LA75A or B amplifier board,
- **RK42F4U-LC75C**  
Powered benchtop case for LA75C amplifier board,
- **RK84F4U-1xLC75B**  
Powered 19" sub-rack for multiple LA75A or B amplifier boards,
- **RK84F4U-1xLC75C**  
Powered 19" sub-rack for LA75C amplifier or multiple LA75A or B amplifier boards,
- **RK84F4U-2xLC75C**  
Powered 19" sub-rack for 2 LA75C amplifier boards,
- **RK84F4U-3xLC75C**  
Powered 19" sub-rack for 3 LA75C amplifier boards,
- **RK84F4U-1xSC75**  
Powered 19" sub-rack for 1 SA75A, B or D switching amplifier board,
- **RK84F4U-2xSC75**  
Powered 19" sub-rack for 2 SA75A, B or D switching amplifier boards.

For driving and/or controlling piezo actuators according to your application, the powered rack can welcome:

- A linear (LA75) or switching (SA75 or SP75) voltage amplifier (see §8.1.3. *Linear voltage amplifiers, page 106* and §8.1.4. *Switching voltage amplifiers, page 106*),
- A sensor conditioning board for monitoring option (see §9. *Sensors & Conditioners, page 121* for description),
- A digital controller board for closed loop control option (see §8.1.6. *Digital controllers, page 110*),

The powered 19" sub-rack series are more versatile and mainly dedicated for laboratory and factory use.



Fig. 8.c: RK42K powered benchtop case



Fig. 8.d: RK84F powered 19" sub-rack

### 8.1.3. LINEAR VOLTAGE AMPLIFIERS

The linear voltage amplifier are designed to be compatible with the RK42F and RK84F powered sub-rack series (see chapter 8.1.2, page 104). The LA75 series of Linear voltage Amplifier board offers the most common solution to drive piezo actuators. The LA75 is designed to drive capacitive loads like piezoelectric actuators with extremely low noise. It can perform amplifying operations in the -20/150 V range. The LA75A-x and LA75B-x can be equipped with the push pull option. LA75A-x is a low-power amplifier integrated on a 19" board and can have up to 3 independent channels. LA75B-x is a medium power amplifier integrated on a 19" board and can have up to 2 independent channels.

The LA75C has a much higher current capability, suited for high frequency and/or short response time/impulse/fast applications. It shows the highest continuous output power capability of the linear voltage amplifiers for piezo actuators available on the market.

See *Table 8.d, page 107* for characteristics.



Fig. 8.g: SA75D amplifier board

### 8.1.4. SWITCHING VOLTAGE AMPLIFIERS

The Switching power Amplifiers SA are designed to be compatible with the Switching Converter SC75 powered sub-rack series (see chapter 8.1.2, page 104). They allow to perform either linear continuous state (SA75) or purely ON/OFF states (SP75) on piezo actuators with extremely short response times. The switching technique allows high current peaks, required by impulse or by high frequency applications on large capacitance piezo actuators.

The SA75A, B and D have max continuous output currents of respectively 5, 10 and 20 Amps.

These amplifier boards can be integrated in either a powered 19" sub-rack RK84F4U-1xSC75 or RK84F4U-2xSC75 for respectively 1 or 2 board arrangements per rack with optional sensor conditioners and digital controllers.

The switching amplifiers have been developed in collaboration with the G2ELAB of UJF Grenoble (France) in the frame of AVIBUS and PPSMPAB projects. Those 2 projects aimed at driving large piezo actuators for fast machining or helicopter flap actuation

See *Table 8.e, page 108* for characteristics.



Fig. 8.e: LA75C, LA75B-2 & LA75A-3 amplifier boards

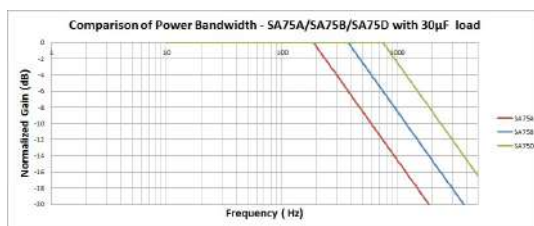

Fig. 8.h: Comparison of power bandwidth for SA75A, B, D for continuous peak output current

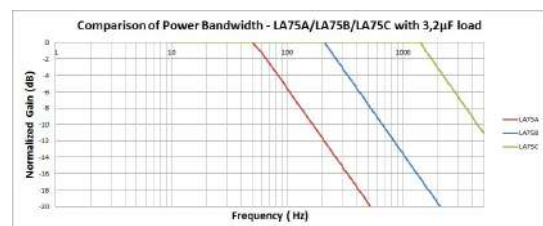

Fig. 8.f: Comparison of power bandwidth for LA75A, B, C for continuous peak output current

PARAMETER <sup>(d.1)</sup>	UNIT	LA75A	LA75B	LA75C
<b>&gt; General</b>				
Function		Driver for piezoelectric actuator		
Number of channels		1 ... 3	1 ... 2	1
<b>&gt; Input</b>				
Control input voltage	V	-1 ... +7.5		
<b>&gt; Output</b>				
Output voltage	V	-20 ... +150		
Continuous peak output current <sup>(d.2)</sup>	mA	±90	±360	± 2 400
Transient peak output current <sup>(d.3)</sup>	mA	-	-	± 6 800
<b>&gt; Power amplifier</b>				
Peak output power <sup>(d.4)</sup>	VA	-	-	360
<b>&gt; Gain</b>				
Gain	V/V	20		
<b>&gt; Dynamic performances</b>				
Small signal bandwidth (-3 dB) <sup>(d.5)</sup>	kHz	30		
<b>&gt; Noise performance</b>				
Signal to noise ratio <sup>(d.6)</sup>	dB	85		
<b>&gt; Protections</b>				
Protections	Overcurrent, overtemperature, overvoltage			
<b>&gt; Options</b>				
Push pull	Capability to drive push-pull piezo mechanisms			
UC55	Controller for position loop - See specific datasheet			
Piezo cable	Specific length on request - Please contact CTEC for more detail			
T LEMO	Able to connect 2 CTEC actuators in parallel - Please contact CTEC for more detail			
LEMO -BNC adapter	Converts LEMO to BNC connector			

Table 8.d Characteristics of LA75A, B &amp; C

d.1 Guaranteed in labs environment

d.2 Electronically limited

d.3 With EPC Enhanced Peak Current - During 600µs with a max repetition rate of 20ms - Internally limited - see specific application note

d.4 Max. instantaneous output power = max(p(t)) = max(u(t) x i(t)), with EPC.

d.5 Unloaded

d.6 Computed as RMS output signal / RMS output Noise floor. [1; 200]Hz

PARAMETER <sup>(E.1)</sup>	UNIT	SA75A	SA75B	SA75D
<b>&gt; General</b>				
Function		Driver for piezoelectric actuator		
Number of channels		1		
<b>&gt; Input</b>				
Control input voltage	V	-1 ... +7.5		
<b>&gt; Output</b>				
Output voltage <sup>(e.2)</sup>	V	-20 ... +150		
Continuous peak output current <sup>(e.3)</sup>	A	±5	±10	±20
<b>&gt; Power amplifier</b>				
Peak output power <sup>(e.4)</sup>	VA	750	1 500	3 000
<b>&gt; Gain</b>				
Gain	V/V	20		
<b>&gt; Dynamic performance</b>				
Small signal bandwidth (-3 dB) <sup>(e.5)</sup>	Hz	3800		
<b>&gt; Accuracy</b>				
Signal to noise Ratio <sup>(e.7) (e.8)</sup>	dB	60		
<b>&gt; Protections</b>				
Amplifier protections	Overcurrent, overtemperature, overvoltage			
Actuator protections	Overcurrent, overtemperature			
<b>&gt; Options</b>				
UC55	Controller for position loop - See specific datasheet			
Piezo cable	Specific length on request			
Multi outputs LEMO front panel	Allows to connect several actuators in parallel - Please contact CTEC for more details			

Table 8.e Characteristics of SA75A, B &amp; D

e.1 Guaranteed in labs environment

e.2 Digitally limited, can be increased to -200 ... +200V upon request

e.3 Electronically limited

 e.4 AC+DC apparent power. For sine signal with offset,  $RMS^2$  is  $(PEAK/\sqrt{2})^2 + OFFSET^2$ 

e.5 Unloaded. Order = 1Vpp

e.6 With 30μF load at 160Vpp

e.7 With 30μF load. Order = 0V

e.8 Computed as RMS output signal/ RMS output Noise floor. 40 Hz ... 20 kHz

### 8.1.5. TWO STATES POWER AMPLIFIER

The Two States Power SP75A amplifier board is a designed two states power driving board.

Only two positions can be obtained:

- OFF position at rest (-20 Volt DC),
- ON position (150 Volt DC).

The two positions are controlled by a TTL signal. The overshoot of the piezo actuator can be reduced after calibrations of the slew rate or the implementation of a signal pre-shaping.



Fig. 8.i: SP75A-2 amplifier board

PARAMETER <sup>(f.1)</sup>	UNIT	SP75A
General		
Function		2 state power driver
<b>&gt; Input</b>		
Control Input voltage	V	0 ... +5 TTL signal / CMOS
<b>&gt; Output</b>		
Output voltage	V	-20 ... +150
Transient peak output current <sup>(f.2)</sup>	mA	±480
<b>&gt; Dynamic performance</b>		
Type of output signal excitation		Preshaping waveform
<b>&gt; Noise performance</b>		
Signal to Noise Ratio <sup>(f.3)</sup>	dB	85
<b>&gt; Protections</b>		
Protections		Overcurrent, Overtemperature, Overvoltage
<b>&gt; Options</b>		
RS422 communication		Capability to communicate the two states order with differential pairs
SG75		Monitoring of the position - See specific datasheet
Piezo cable		Specific length on request - Please contact CTEC for more detail
LEMO -BNC adapter		Converts LEMO to BNC connector

Table 8.f Characteristics of SP75A

f.1 Guaranteed in labs environment

f.2 Electronically limited

f.3 Computed as RMS output signal / RMS output noise floor. [1;200]Hz

## 8.1.6. DIGITAL CONTROLLERS



Fig. 8.j: UC55 controller board

For closed loop applications (Fig. 2.w), Cedrat Technologies (CTEC) offers different solutions built around digital controllers in order to adapt to the application's requirements. All controllers come with a USB connection for interfacing with a computer. The controllers implement PID real-time control with additional stabilising output filters (low-pass filters, notch filters). They feature analog inputs for the orders and sensors, and analog outputs for the commands to the amplifiers. The different control parameters can be tuned through the USB connection. Dedicated GUI software is provided to allow easy tuning of the control laws and ordering displacements. This software is called HDPM.

Under specific request, there is also the possibility to send commands to the controllers over the serial connection instead of the analog inputs.

The UC55 control board is plugged as a daughter board into amplifier board and integrates a single channel digital controller that achieves control rate in accordance with CTEC mechanism.

In single channel, the control rate is 30 kSps, in dual channels, 15 kSps, and in triple channels, 10 kSps. The UC55 boards can also be stacked to handle several independent control channels at high frequency (up to 3).

PARAMETER	UNIT	UC55
<b>&gt; General</b>		
Function		Digital controller with analog I/Os
Number of control channels		1 ... 3
Digital communication		USB
Graphical User Interface		CTEC HDPM
<b>&gt; Digital control</b>		
Control strategy		Tunable PID + Stabilising filters
Sampling rate	kSps	10 / 15 / 30 <sup>(k.1)</sup>
Digital resolution	bits	16
<b>&gt; Analog inputs</b>		
Analog inputs voltage range	V	-10 ... +10
<b>&gt; Analog outputs</b>		
Analog outputs voltage range	V	-10 ... +10
<b>&gt; Miscellaneous</b>		
Product compatibility		LA75 and SA75 series

Table 8.k Characteristics of UC55 controller boards

k.1 10kSps for 3 channels, 15kSps for 2 channels, and 30kSps for 1 channel



### 8.1.7. CUSTOMISED AMPLIFIERS AND CONTROLLERS

#### LINEAR CHARGE AMPLIFIER

This linear charge amplifier based powered rack is derived from the linear voltage amplifier board LA75B. The piezo actuator is driven with electric charge instead of voltage in order to reduce the hysteresis effect below 1 % in open loop and dynamic conditions. This charge amplifier option is available for LA75A and B boards under request. (see Fig. 8.k and Fig. 8.l)

#### MULTICHANNEL LA75C POWERED 19" SUB-RACK CABINET

This combination of 4 LA75C with SG conditioner and digital controller boards is implemented inside a RK84F-9U cabinet in order to drive and to control in push pull configuration some large piezo Tip Tilt, XY stages or fast steering platforms. (see Fig. 8.m)

#### HIGH VOLTAGE MULTICHANNEL AMPLIFIER RACK

This 18 channels combination allows to drive simultaneously 18 high voltage piezo actuators (from -200 to +200 V) (see Fig. 8.n)

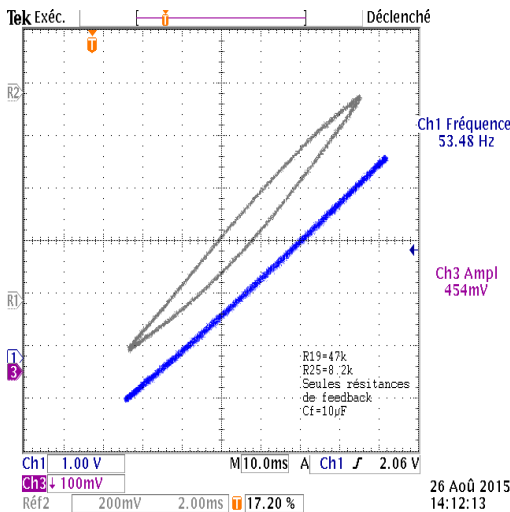

Fig. 8.k: Hysteresis plot of displacement versus input voltage for a linear voltage amplifier (grey curve) and for a linear charge amplifier (blue curve)

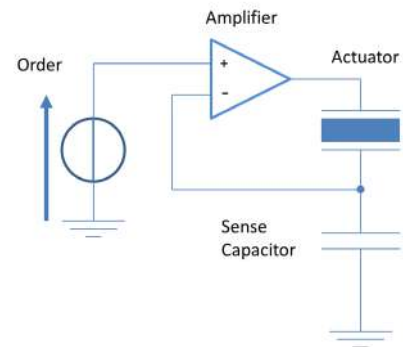

Fig. 8.l: Schematic of a charge amplifier



Fig. 8.m: Rack cabinet mounted LA75C push pull amplifier channels for driving large capacitance piezo mechanism



Fig. 8.n: 18 amplifier channels rack for high voltage piezo actuators

## 8.2. AMPLIFIER FOR MAGNETIC ACTUATORS

### 8.2.1. OEM SERIES

#### COMPACT LINEAR POWER AMPLIFIER MCLA18



Fig. 8.o: MCLA 18

The Compact Linear Power Amplifier MCLA18 is a compact size 2 channels push pull controller box with large output power capability.

The MCLA18 is relevant for driving & control the motion of either 2 single axes MICA™ or dual axis magnetic actuators like Magnetic Fast Steering Mirror (M-FSM™) along large operating bandwidth.

PARAMETER <sup>(g.1)</sup>	UNIT	MCLA18
<b>&gt; General</b>		
Function		All-in-one magnetic driver and controller
Number of channel		2
Digital communication		RS422, USB
DC main supply voltage	VDC	±15 ... ±36
<b>&gt; Digital control</b>		
Processor		Floating-point microcontroller
Control strategy		Dedicated control for magnetic mechanism
Sampling rate	kSps	100
Digital resolution	bits	16
<b>&gt; Input</b>		
Number of analog inputs		4
Control input voltage (Vin+ - Vin-)	V	-10 ... +10
<b>&gt; Output</b>		
Output voltage	V	±10 ... ±32
Continuous output current <sup>(g.2)</sup>	A	±1
Minimum output load	μH	0
<b>&gt; Power amplifier</b>		
Number of channels		2
Max. continuous output apparent power <sup>(g.2)</sup>	VA	32
Max. continuous output active power	W	1 x 32max (or 2 x 16max)
Gain	A/V	0.1
<b>&gt; Protections</b>		
Protections		Reverse Polarity, Current Limitation (Amplifier), Overtemperature (Amplifier)

g.1 Guaranteed in labs environment

g.2 Depending of the output voltage - See Fig. 8.p

Table 8.g Characteristics of MCLA18

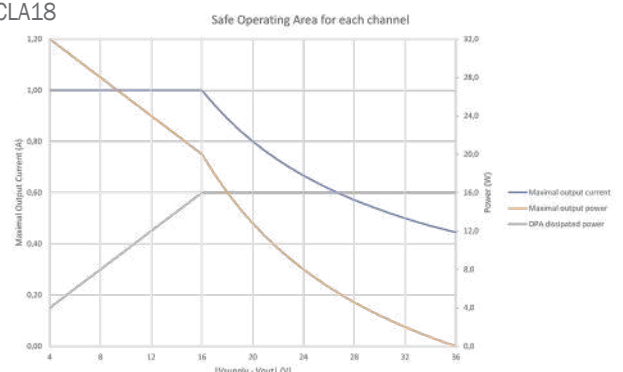

Fig. 8.p: MCLA18 Operating Graph

## COMPACT SWITCHING AMPLIFIER MCSA480



Fig. 8.q: MCSA 480

The Compact Switching Amplifier MCSA480 is a compact size 2 channels push pull controller box with large output power capability (max. 480 VA ~ 48 V × 10 A).

The MCSA480 is relevant for driving & control the motion of either 2 single axis MICA™ or dual axis magnetic actuators like Magnetic Fast Steering Mirror (M-FSM™) along large operating bandwidth (>100 Hz).

> [See MCSA480 full datasheet](#)

PARAMETER	UNIT	MCSA480 <sup>(h.1)</sup>
<b>&gt; General</b>		
Function		All-in-one magnetic driver and controller
Number of control channels		2
Digital communication		RS422, Ethernet (optional), USB
Graphical User Interface		CTEC HDPM
<b>&gt; Digital control</b>		
Control strategy		Specific Control
Sampling rate	kSps	100
Digital resolution	bits	16
<b>&gt; Analog inputs</b>		
Number of analog inputs		4
Control input voltage (Vin+ - Vin-)	V	-10 ... +10
<b>&gt; Output</b>		
Output voltage range <sup>(h.2)</sup>	V	-48 ... +48
RMS output current	A	±7
<b>&gt; Power supply</b>		
Supply voltage range	Vdc	24 ... 48
<b>&gt; Power amplifier</b>		
Number of channels		2
<b>&gt; Protections</b>		
Protections		Overcurrent (Actuator & Amplifier), Overtemperature (Amplifier), Reverse Polarity, Overvoltage (input), Undervoltage (input)
<b>&gt; Options</b>		
Actuator cable		Specific length on request.

Table 8.h Characteristics of MCSA480

h.1 Guaranteed in labs environment

h.2 (1) Limited by supply voltage.

## LINEAR POWER AMPLIFIER FOR MAGNETIC ACTUATOR CMA $\mu$ 10

The following linear amplifier is designed to drive inductive loads like magnetic actuators with extremely low noise. The new CMA $\mu$ 10 is a compact and standalone unit specially designed for driving magnetic products such as MICA20CS actuators. The CMA $\mu$ 10 includes a current closed-loop control and is ideal for driving small size actuators from CTEC and other actuators such as voice coils and moving magnet actuators, for linear or tilting motion.



Fig. 8.r: CMA $\mu$ 10

PARAMETER <sup>(1,1)</sup>	UNIT	CMA $\mu$ 10
<b>&gt; General</b>		
Function		Driver for magnetic linear actuator
Number of channel		1
<b>&gt; Input</b>		
Control input voltage (Vin+ - Vin-)	V	-10 ... +10
<b>&gt; Output</b>		
Output voltage	V	$\pm 32$
Continuous output current <sup>(1,2)</sup>	A	$\pm 0.5$
Minimum output load	$\mu$ H	100
<b>&gt; External power supply</b>		
DC main supply voltage	VDC	24
DC additional supply voltage	VDC	$\pm 36$
<b>&gt; Power amplifier</b>		
Max. continuous output apparent power <sup>(1,3)</sup>	VA	16
Max. continuous output active power	W	16
<b>&gt; Gain</b>		
Gain	A/V	0.05
<b>&gt; Protections</b>		
Protections		Current limitation, Overtemperature indicator

Table 8.i Characteristics of CMA $\mu$ 10

i.1 Guaranteed in labs environment

i.2 Depending of the output voltage - See Fig. 8.t

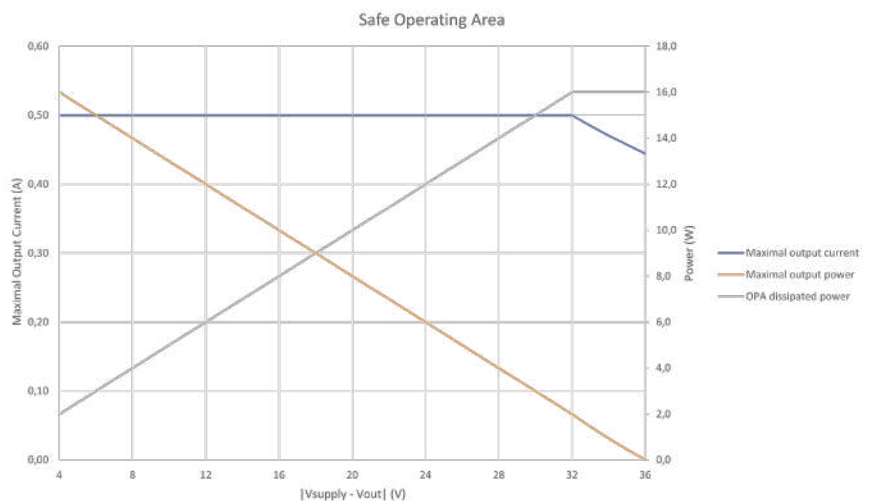

Fig. 8.s: CMA $\mu$ 10 Operating Graph

## 8.2.2. CUSTOMISED AMPLIFIERS & CONTROLLERS

### POWERED CASE CONTROLLER

This powered case includes a DC/DC converter, a linear amplifier, a positioning sensor conditioner and a controller boards in order to control a moving coil based mechanism for high accuracy indent instrument.



Fig. 8.t: Powered case controller for driving moving coil mechanism

### OEM COMPACT AMPLIFIER BOARD

This CLAu10 offers a compact linear amplifier board solution to drive magnetic actuators such as MICA™ or Moving Coil Actuators.



Fig. 8.v: OEM amplifier board for driving magnetic actuators

### COMPACT SWITCHING AMPLIFIER CSA96

The Compact Switching Amplifier CSA96 is a compact size and large output power amplifier box for driving linear magnetic actuators like Moving Iron Controllable Actuator (MICA™). This CSA96 box is supplied by an External DC power supply up to 96 VDC.



Fig. 8.u: CSA96

## 8.3. CONTROLLER FOR PIEZO MOTORS

Piezo motors always need the combination of a positioning sensor feedback and a controller to be used as accurate positioners or motion providers within mechatronic system. The piezo motor technology developed by CEDRAT TECHNOLOGIES (CTEC) is called Stepping Piezo Actuator (SPA).

### 8.3.1. CONTROLLER BOARD FOR STEPPING PIEZO ACTUATOR



Fig. 8.w: SPC45 piezo motor controller board

The Stepping Piezo Controller SPC45 is a versatile, single channel controller board offering an off the shelves solution to control either the Linear Stepping Piezo Actuator LSPA30uXS or the Linear Stepping Piezo Stage LSPS35XS. The SPC45 controller board is included in the developer kit and provide the user with many features in terms of command & control options (step, position), digital or analog I/O connections as well as a user-friendly graphical interface to adjust the motor performances according to the system integration requirements.

PARAMETER	UNIT	SPC45
<b>&gt; General</b>		
Number of control channels		1
Integated sensor conditioning <sup>(i.1)</sup>		Quadrature encoder interface
Digital communication		USB
Graphical User Interface (GUI)		CTEC IHM SPC45
<b>&gt; Analog inputs</b>		
Number of analog inputs		1
Analog inputs voltage range	V	0 ... 5
<b>&gt; Analog outputs</b>		
Number of analog outputs		1
Analog outputs voltage range	V	0 ... 5
<b>&gt; Piezo driver</b>		
Number of channels		1
Nominal output voltage range	V	5 ... 96.5
Peak output current	A	0.15
<b>&gt; Power supply</b>		
Supply voltage	Vdc	9 ... 24
Supply current	Arms	0.1 ... 0.56
<b>&gt; Miscellaneous</b>		
Mass	kg	0.11
Dimensions	mm <sup>3</sup>	91 × 66 × 22

Table 8.j Characteristics of SPC45

j.1 Sensor gain adjustable through GUI

### 8.3.2. CUSTOMISED CONTROLLERS FOR PIEZO MOTOR BASED MECHANISMS



Fig. 8.x: Controller box for 3 axis piezo motorised mechanism



Fig. 8.y: Controller box for 2 axis piezo motorised mechanism

CTEC had already developed from customer specifications some piezo motor based mechanisms with several degrees of freedom requiring multi-channel and complex control features (see chapter §6.6. *Customised piezo motor mechanisms, page 89*). CTEC custom designed controller boxes in order to meet the functional requirements of the customer system.

Fig. 8.s shows a controller box to drive and to control simultaneously and independently 2 piezo motorised axes with submicron position repeatability & non colliding protocol.

Fig. 8.t shows a controller box to drive a compact piezo motorised sample along 3 degrees of freedom with accurate tracking & flexibility in motion pattern follow up.







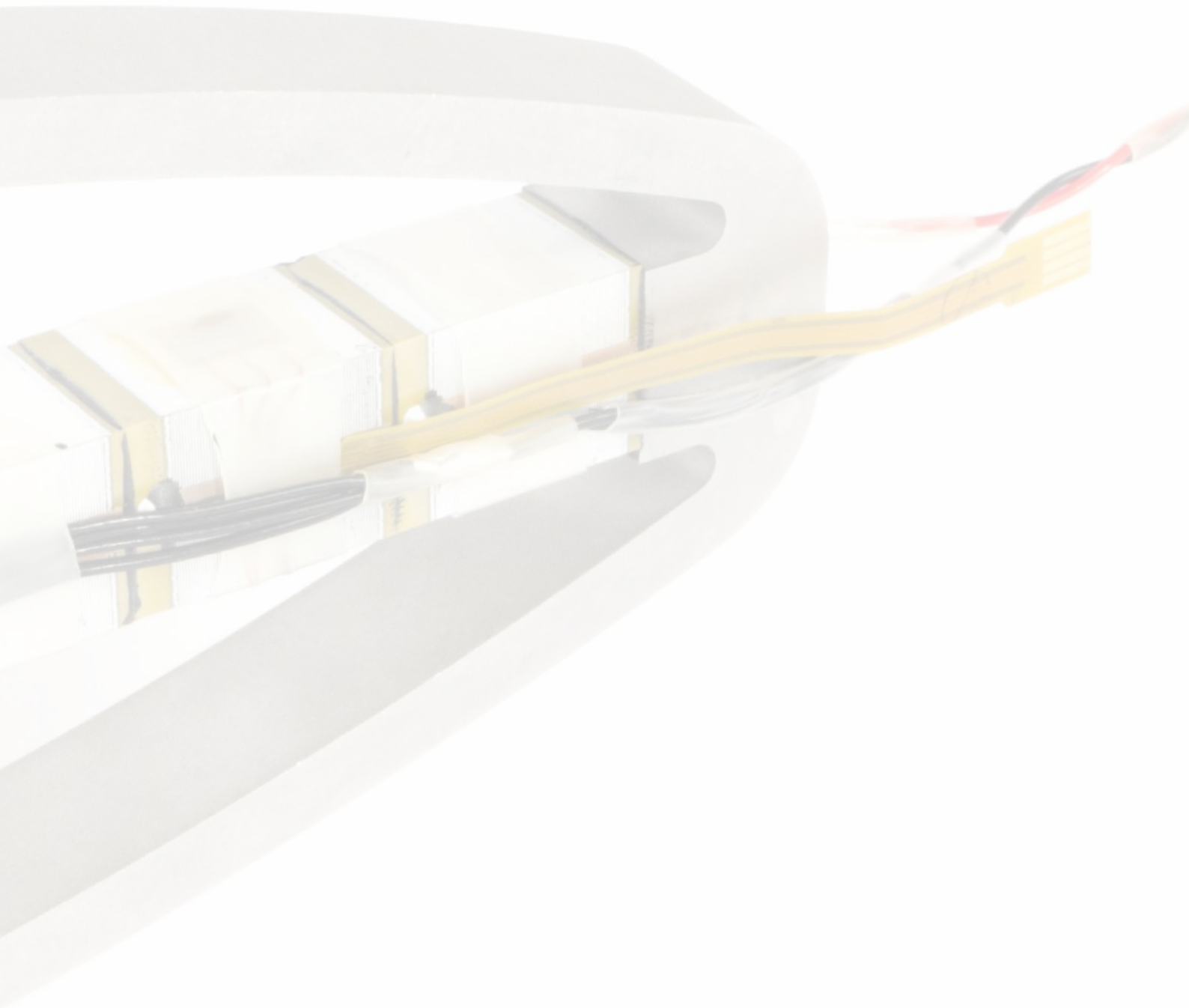

**For more information on this chapter,  
please visit these pages:**

*[cedrat-tec.com/products/sensors](https://cedrat-tec.com/products/sensors)*

*[cedrat-tec.com/technologies/sensors](https://cedrat-tec.com/technologies/sensors)*

## 9. SENSORS & CONDITIONERS

### 9.1. SELECTION GUIDE

Positioning sensors available on the market can hardly keep pace with the accuracy requirements when scaling down the mechatronic system.

That is why CEDRAT TECHNOLOGIES (CTEC) has developed different kinds of sensors for answering to this problematic of accuracy requirements in a compact volume.

To monitor actuator displacement or implement a closed loop control, CTEC offers several solutions that allow the customer to build a system corresponding to its requirement.

Different kinds of sensor technologies are available:

- **Strain Gauges (SG)** are contact sensors measuring the deformation of the piezo ceramics. They are a standard option in piezo actuators (APA®, MLA, PPA) and in some piezo mechanisms (TT, XY...).
- **Eddy Current Probes (ECP)** are contactless sensors measuring the distance between the sensor and a target. They are an option for several types of APA© piezo actuators and in some piezo mechanisms (TT, DTT, XY). They can be used also with magnetic actuators.

Sensor conditioning boards are available for these two types of sensors. They can be implemented in powered racks in combination with controllers and amplifiers to obtain a complete closed loop system.

Both technologies are further presented in §9.2. *Strain gauges & associated conditioners, page 122* and §9.3. *Eddy Current Sensors & associated conditioners, page 124*.

CTEC also integrates to its mechanisms other types of sensors from third party manufacturers, such as incremental magnetic sensors, optical encoders, accelerometers, capacitive sensors, end-of-stroke detectors, limit switch sensor, thermal sensors, etc (see §9.4. *Customised sensors' solutions, page 128*).

Independently from actuators and mechanisms, CTEC manufactures non-contact inductive sensors for position measurement in the centimeter range as well as long range magnetic detection systems and acoustic piezo-based Structural Health Monitoring solutions (see §9.4. *Customised sensors' solutions, page 128*).

Please contact CTEC by phone or email at [actuator@cedrat-tec.com](mailto:actuator@cedrat-tec.com) for more detailed information and help in the selection of your configuration.

## 9.2. STRAIN GAUGES & ASSOCIATED CONDITIONERS

### 9.2.1. STRAIN GAUGE SENSORS

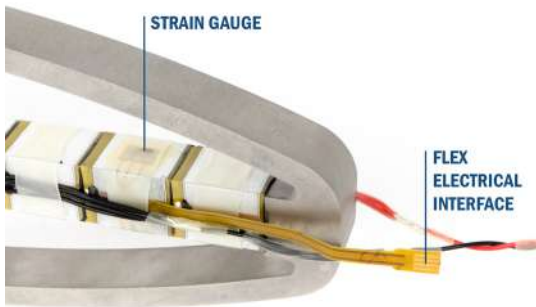

Fig. 9.a: Strain Gauge on MLA on an APA1000XL

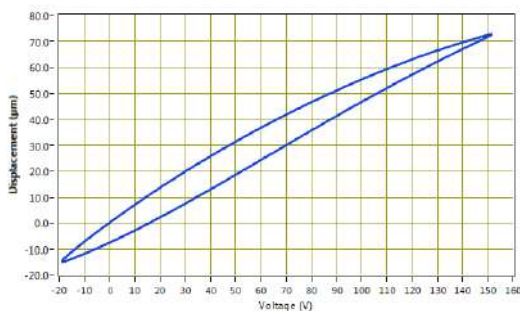

Fig. 9.b: APA60SM-SG stroke versus voltage in open loop

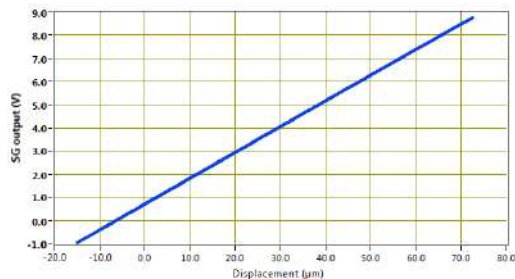

Fig. 9.c: APA60SM-SG stroke versus voltage in closed loop



Fig. 9.d: SG75

The Strain Gauge (SG) Sensor is a contact sensor which is bonded onto a proof body in order to measure its deformation. In CEDRAT TECHNOLOGIES (CTEC) piezo actuators, the proof body is generally the Multi Layer Actuator (MLA) piezo ceramics, although for some cases the APA® shell can also be used as the proof body.

It allows to monitor the displacement of the actuator and to implement a closed loop control.

#### Measuring principle:

The SG transforms applied strain into a proportional change of resistance. The relationship between the applied strain  $\varepsilon$  ( $\varepsilon = \Delta L / L_0$ ) and the relative change of the resistance of a SG is described by the equation:

$$\frac{\Delta R}{R_0} = k \cdot \varepsilon$$

where  $k$  is the gauge factor of the SG.

The small variation of strain induces a small variation of the voltage. In the piezo actuator, it gives an image of the actuator total stroke. So a wheatstone bridge is built using 4 SG in a specific configuration. This configuration is well known to improve the measurement of small variations of resistance.

The SG sensor is well adapted for applications requiring good resolution and linearity. These performances are given with the electronics in the next section (see Fig. 9.b and Fig. 9.c).

CTEC has performed a Space Qualification of its process of SG Sensor bonded on piezo MLA. This Space Qualification has established a high reliability and an excellent time stability of its SG for piezo actuator.

General specifications are given in Table 9.a.

### 9.2.2. STRAIN GAUGES CONDITIONERS

The SG75 Strain Gauges Conditioner (Fig. 9.d) converts the signal from the Strain Gauge sensor. It is implemented on a 19" board and can include up to 3 independent channels.

General specifications are given in Table 9.b.

Up to date precision specifications (as regard linearity, drift, etc...) are given on SG75 datasheet on CTEC website.

PARAMETER	UNIT	TYPICAL VALUE
<b>&gt; General</b>		
Function		Contact sensor using strain gage technology
<b>&gt; Electrical</b>		
Bridge impedance	$\Omega$	350
Bridge excitation	V	2.5 ... 10
<b>&gt; Type of Measurement</b>		
Deformation		
Resolution	% FS <sup>(a.1)</sup>	0.01
Creep	% FS <sup>(a.1)</sup>	< 0.5
Thermal Offset drift	% FS <sup>(a.1)</sup> / °C	0.05
Thermal gain drift	% FS <sup>(a.1)</sup> / °C	0.01
Long term stability (30 days)	% FS <sup>(a.1)</sup>	0.01
<b>&gt; Miscellaneous</b>		
Dimension		Mounted on MLA <sup>(a.2)</sup>
Actuator compatibility		All APA® and PPA except APA30uXS, APA150XXS & APA50XS
Operating temperature range	°C	-75 ... +95
Compliant with actuator 'vacuum' option		
Other interfaces on request		

Table 9.a Specifications of Strain Gauge (SG) sensor

PARAMETER	UNIT	TYPICAL VALUE
<b>&gt; General</b>		
Function		Conditionner of strain gage sensor
Number of channels		1 ... 3
<b>&gt; Input</b>		
Sensor type		Full bridge, strain gauge-based, 4 wires
Bridge impedance	$\Omega$	350
Bridge excitation <sup>(b.1)</sup>	V	5
Gain span <sup>(b.2)</sup>		116 ... 2 700
<b>&gt; Output</b>		
Typical output voltage <sup>(b.3)</sup>	V	±10
Bandwidth -3 dB	kHz	15
<b>&gt; Accuracy</b>		
Resolution	% FS <sup>(a.1)</sup>	0.01
Linearity	% FS <sup>(a.1)</sup>	0.01
Thermal offset drift <sup>(b.4)</sup>	% FS <sup>(a.1)</sup> / °C	±0.025
Thermal gain drift <sup>(b.5)</sup>	% FS <sup>(a.1)</sup> / °C	± 0.1
<b>&gt; Miscellaneous</b>		
Operating temperature range	°C	0 ... 40
<b>&gt; Included Accessories</b>		
Strain Gauge cable		Shielded 1.5 m

Table 9.b Specifications of SG75

a.1 FS: Full Stroke (FS) corresponds to the stroke of the piezoelectric actuator

a.2 MLA: Multi layer Actuator (piezo ceramic)

b.1 Alternative voltage 2.5, 7.5, 10 V available on request

b.2 Other values on request

b.3 Set to [-1 V ; 7.5 V] on CTEC systems to be consistent with driver input

b.4 Could be reduced by deleting the offset adjustment

b.5 Maximum drift with conditioner gain of 1000

## 9.3. EDDY CURRENT SENSORS & ASSOCIATED CONDITIONERS

### 9.3.1. EDDY CURRENT SENSOR PROBES ECP

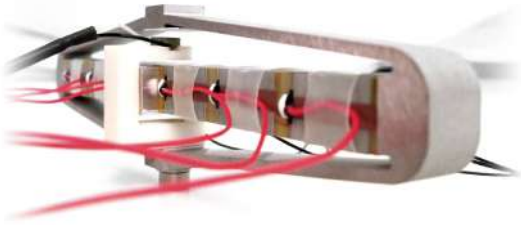

Fig. 9.e: APA500L integrating a naked ECP500 in front of a target

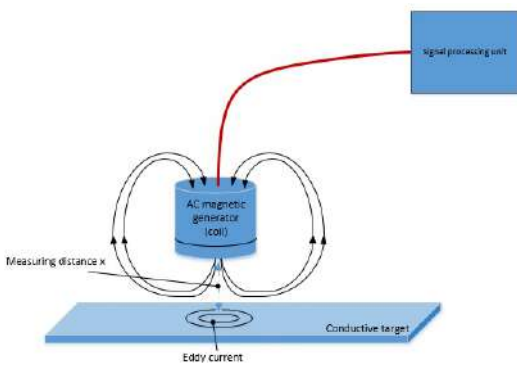

Fig. 9.f: Physical principle of an Eddy Current Sensor probe in front of a target



Fig. 9.g: ECP Probe

Eddy Current Sensing (ECS) is a contactless proximity method for measuring the distance between a probe and a conductive target. It requires:

- an Eddy Current Probe (ECP) placed in front of the Target
- an ECS electronic conditioner, as the ECS45, ECS75, ECSu10,

The measuring principle is shown on Fig. 9.f: the ECP features an induction coil in which an alternating current is applied. It generates an oscillating magnetic field in the conductive target, in side which eddy currents are induced. These eddy currents generate an induced magnetic field the amplitude of which decreases with the distance between the target and the probe. This induced field is then detected by the ECP, giving a signal amplified by conditioner (see §9.3.2. *Eddy Current Probe conditioners ECS, page 126*).

From its long experience in magnetic devices design, Cedrat Technologies (CTEC) developed a unique ECP which is extremely compact, thanks to the direct integration of the inductive coil inside a PCB. This technology also takes benefit of space qualification, meaning performance and robustness.

The ECP is well adapted for distance measurement requiring higher resolution, high bandwidth and a contactless sensing area.

The ECP is able to sense sub-micron positions in sub-millimeter and millimeter ranges. High precision is obtained when combined with ECS conditioners.

For optimal performances, the target should be preferably made of nonmagnetic conductive materials such as aluminum. Stainless steel is another candidate but with less sensitivity.

Standards ECP are proposed in two versions with a different measurement range: 500  $\mu\text{m}$  for the ECP500 and 1000  $\mu\text{m}$  for the ECP1000, but customized versions can be easily derived. CTEC could adapt ECP for specific volume with the naked ECP pattern PCB. The "shielded" version could be provided with straight or right angle output cable.

PARAMETER	UNIT	ECP500	ECP1000
		Preliminary data <sup>(c.1)</sup>	
Sensor type		Eddy Current Sensor	
<b>&gt; Electrical characteristics</b>			
Range of excitation frequency	kHz	>500	
<b>&gt; Mechanical characteristics</b>			
Probe diameter	mm	8.0	15.0
Probe height	mm	7.0	
<b>&gt; Measurement Range</b>			
Nominal range	µm	500	1 000
Extended range	µm	1 000	2 000
<b>&gt; Typical accuracy achieved after conditioning</b>			
Resolution (BW = 20 kHz) <sup>(c.2)</sup>	% FS <sup>(c.3)</sup>	0.010	
Resolution (BW = 1 kHz)	% FS <sup>(c.3)</sup>	0.003	
Resolution (BW = 20 kHz), extended range (2000 µm)	% FS <sup>(c.3)</sup>	0.015	
Resolution (BW = 1 kHz), extended range (2000 µm)	% FS <sup>(c.3)</sup>	0.005	
<b>&gt; Operating Environment</b>			
Operating temperature range	°C	-25 ... +70	
<b>&gt; Options</b>			
Straight / Right Angle cable			
Integration on CTEC APA® actuators or mechanisms			

Table 9.c Characteristics of Eddy Current Probes

c.1 Guaranteed in labs environment

c.2 BW: Bandwidth

c.3 FS: Full Scale

### 9.3.2. EDDY CURRENT PROBE CONDITIONERS ECS

CEDRAT TECHNOLOGIES' (CTEC) ECS electronics manage the signal from the ECP Eddy Current Probe to provide an information of the probe-to-target distance.

The ECS75 (Fig. 9.j) is a conditioning board implemented on a 19" board, offering up to 3 independent channels, offering linearised sensing responses. This board can be integrated to the RK42F and RK84F racks for piezo actuators.

The ECS45 (Fig. 9.i) is a standalone conditioner based on the ECS75, and so also offering linearized sensing responses.

High precision is achieved considering low linearity error.

ECS75 features a new the "Thermally Stable" design since 2017 in standard. The drift in measured values due to thermal fluctuations of the environment is significantly reduced. This addresses a major drawback of the eddy current sensing technologies for these types of environment.

The thermally stable design is also implemented to the ECS45, the standalone version of the ECS75 which is integrated in a housing supplied by an external DC power supply.

ECS75 and ECS45 conditioners linearize the output from the ECP probe with a high order polynomial function programmed in a digital component. The gain of each channel is generally set when the Eddy Current Probe is embedded in the mechanism.

Additionally, CTEC proposes a cost-effective and compact OEM conditioner ECSu10 (Fig. 9.h) that can be easily integrated by the customer. It is built around the input analog stage of the ECS75 board but without the digital stage performing the linearisation and without the new thermal compensation.



Fig. 9.h: ECSu10



Fig. 9.i: ECS45 standalone



Fig. 9.j: ECS75 board



PARAMETER	UNIT	ECSu10	ECS45	ECS75
		Preliminary data	Preliminary data	Preliminary data
Number of channels			2	1 ... 3
<b>&gt; Input</b>				
Sensor type		CTEC Eddy Current Probe	CTEC Eddy Current Probe	CTEC Eddy Current Probe
<b>&gt; Electrical characteristics</b>				
Power Supply	Vdc	15 +/- 5 %	24 +/- 5 %	
<b>&gt; Output</b>				
Typical output voltage <sup>(d.1)</sup>	V	0 ... 10	±10	±10
Output current <sup>(d.2)</sup>	mA	4 ... 20		
Bandwidth - 3dB (extended on request)	kHz	15	20	20
<b>&gt; Typical achieved accuracy</b>				
Resolution (BW = 20kHz) <sup>(d.3)</sup>	% FS <sup>(d.4)</sup>	0.005	0.010	0.010
Resolution (BW = 20kHz), extended range <sup>(d.3)</sup>	% FS <sup>(d.4)</sup>	0.008	0.014	0.014
Linearity <sup>(d.5)</sup>	% FS <sup>(d.4)</sup>	±25	0.1	0.1
Thermal drift	% FS <sup>(d.4)</sup> / °C	0.2		
<b>&gt; Options</b>				
Differential output (with two probes)			Yes	Yes

Table 9.d Characteristics of Eddy Current Probe Conditioners ECS

d.1 Set to [-1V ; 7.5 V] on CTEC systems to be consistent with driver input - Could be adjusted with customer specification

d.2 [4-20 mA] output

d.3 BW: Bandwidth

d.4 FS: Full Scale

d.5 Better linearity can be achieved on request

## 9.4. CUSTOMISED SENSORS' SOLUTIONS

### 9.4.1. CUSTOMISED SENSOR'S INTEGRATION



Fig. 9.k: Linear magnetic encoder (hall effect sensor)



Fig. 9.l: Three axes accelerometer PCB mounted

Besides the SG & ECS positioning sensor technologies described in the previous paragraphs, CEDRAT TECHNOLOGIES (CTEC) have been integrating other type of sensors available on the market inside its customised mechatronic systems for decades. This integration covers mechanical, electronic & control issues.

For instance, CTEC get use to integrate different type of magnetic or optical encoders (see Fig. 9.k) to provide customers with long range (Several mm) & accurate (micron or nano-meter) positioning control.

CTEC also integrates force, gyros, speed or accelerometer sensors (see Fig. 9.l) for various mechatronic functions such like active stabilization, tracking, damping, isolation or control of vibrations.

The selection of the sensor and the control strategy will be made according to the customer specifications and application (payload, mechanical structure, environmental and boarding conditions...).

In the frame of our detection systems' activities, CTEC also integrated various type of temperature and pressure sensors.

On top of this sensors' integration know-how, CTEC develops customised sensor and detection solutions, as shown in the following paragraph to answer to customer's specific needs.

### 9.4.2. CUSTOMISED MAGNETIC SENSORS & DETECTION SYSTEMS

Magnetic sensors offer potential for contactless detection techniques. These magnetic sensing technologies are recurrently exploited by CTEC to provide various innovative customized solutions, either as components or as complete systems.

Its Eddy Current Sensors products are used for high precision motion control on distance up to 3 mm. They are used in its actuators or for making customized force & torque sensors as well as top counter sensors.

In machine tool, force feedback systems are requested to measure forces exerted to the workpiece during the cutting operation. To meet this demand, a cost-effective Force Sensing Table with a diameter 100 mm and a height of 70 mm is capable of measuring forces in one direction only with a range of  $\pm 20$  kN, a resolution of 12 N and accuracy of better than 50 N at 1 kHz.

Following the same approach, three axis force feedback table and Single axis force feedback tool holder are also developed.

Customized Robust & Cost effective Contactless Torque Sensors (CTS) have also been developed for automotive and aircraft. The concept is



Fig. 9.m: MC-Suite force sensing table (See [cedrat-tec.com/services/engineering/collaborative-projects](http://cedrat-tec.com/services/engineering/collaborative-projects))



Fig. 9.n: CTS Contactless Torque Sensor

based on a patented torsion converter and an ECS-based proximity sensor. Different CTS can cover various torques from 1 to 500 N.m, with resolution of 0.1 %.

Using its ECS technology, an accurate contactless top counter sensor has been space qualified for EUCLID-NISP Cryomechanism for CEA. This generates a precise top signal at each rotation with an angular repeatability under  $\pm 0.25^\circ$  while operating at 20°K in vacuum.

To offer cost-effective contactless solutions for tyre thickness measurements, 3 different inductive sensor types have been developed and patented in collaboration with MICHELIN MFP (see Fig. 9.p):

- HMP: Hall sensor and Magnet Position sensor
- PCI: Pot shape Coil Inductive sensor
- PCT: Planar shape Coil Transformer

They allows distance measurements up to 40 mm, with power as low as 0.3 mW, weight lower than 6 gr, resolution 0.1 mm.

In the frame of ROXTAR medtec project, CTEC has developed an accurate Magnetic 6 DoF Alignment Localization & Tracking (MALT) system offering a detection range larger than 1 m.

The MALT system is based on 3 sub-systems:

- a magnetic fields emitter and placed on the X Ray emitter
- a sensor systems placed in the X Ray detector plate
- a PC with electronics and a Graphical User Interface (GUI)

Localization resolutions are 0.5mm in horizontal plane, 5 mm along vertical axis, and  $0.1^\circ$  in angle., within a latency of 300 ms.



Fig. 9.o: EUCLID-NISP top counter sensor



Fig. 9.p: PCI inductive sensor for MICHELIN MFP

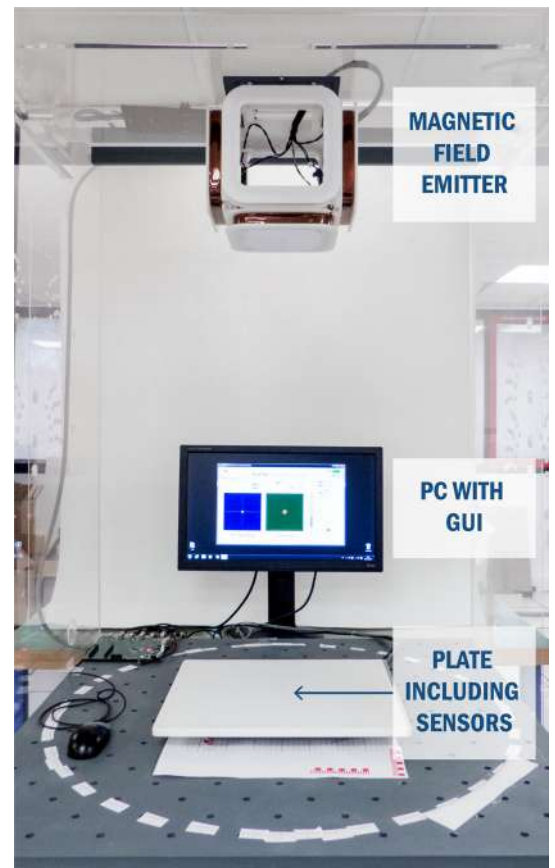

Fig. 9.q: 1 meter range MALT for ROXTAR

### 9.4.3. NON-DESTRUCTIVE TESTING NDT & STRUCTURAL HEALTH MONITORING SHM

Non-Destructive Testing (NDT) consists of sensing techniques for material, component or system without causing damage. Among them, Structural Health Monitoring (SHM) is an embedded NDT for detecting damages of a mechanical structure over time.

CEDRAT TECHNOLOGIES (CTEC) has an extensive experience in the field of piezo transducers, magnetic generators and sensors as well as their related electronics (driving, sensing, controlling), which served as a basis to develop powerful NDT or SHM-dedicated electronics solutions.

NDT activities at CTEC consists in developing various acoustic & electromagnetic techniques for dedicated needs, based on:

- Piezo actuators, transducers & sensors
- Strain gages on specific proof bodies
- Specific Eddy Current Sensors
- Reluctance magnetic sensors
- Direct magnetostriction effect (occurring when the magnetic properties are changed with mechanical stress)

These techniques applies on pipelines, ferromagnetic cables, on-line inspection of rolled steel manufacturing, weigh in motion (WIM), etc

One SHM technique developed by CTEC is to emit and receive ultrasonic waves with piezo-electrical transducers attached to the structure. The propagation of the wave is analyzed to evaluate the presence of damages inside the structure. This ultrasonic detection method is particularly appropriate to monitor health of large structures whose systematic inspections are mandatory but costly, such as aircrafts, spacecrafts, boats, bridges, cables, pipes, etc...

The proposed solutions consist in designing piezo patches, driving and sensing electronics, ranging from the pure analog rack to the fully programmable solution delivered with Graphical User Interface (GUI). According to the application, operating frequencies varies from 1 kHz to 1 MHz.

For example in Fig. 9.t, a LWDS45 board from CTEC is connected to two piezo patches. A patch is electrically excited to generate a pulse (see Fig. 9.u). Then the LWDS switches to a listening mode on both patches (pulse-echo technique). The detected signals are recorded, and compared to previous records. If signal changes are detected, it means a damage has appeared in the plate.

Fig. 9.u shows a 18 channels electronics for piezo patch excitations for SHM.

For more information on customised sensors' solutions, please see:

[cedrat-tec.com/products/sensors/eddy-current-sensors](http://cedrat-tec.com/products/sensors/eddy-current-sensors) and  
[cedrat-tec.com/technologies/sensors](http://cedrat-tec.com/technologies/sensors)

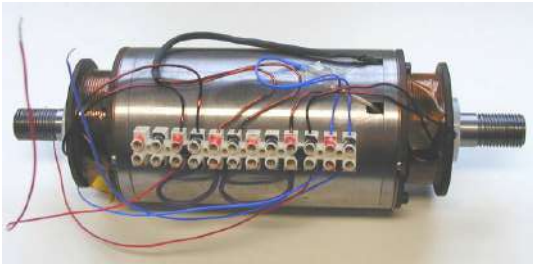

Fig. 9.r: Monitoring stress in bridge cable

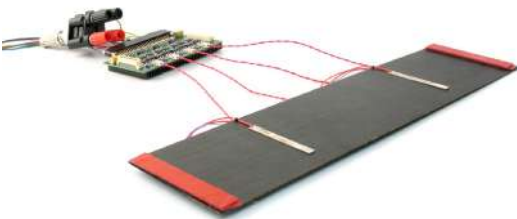

Fig. 9.s: Test bench for SHM : LWDS45 board connected to 2 piezo patches

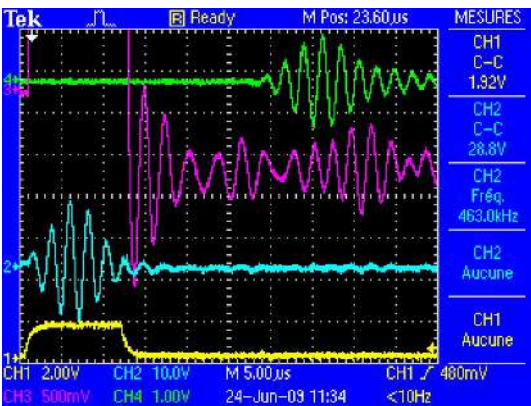
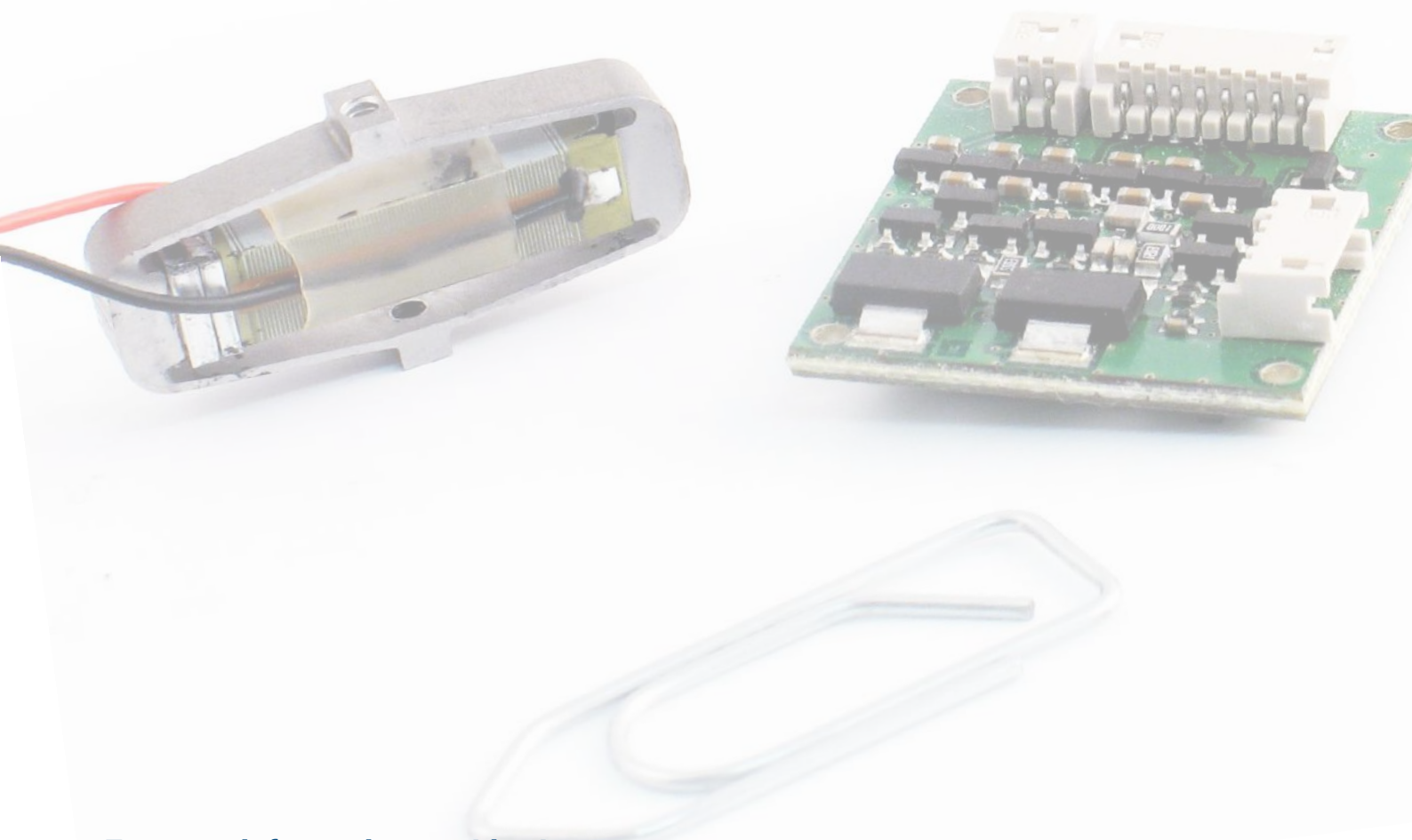

Fig. 9.t: Pulse-echo acoustic signals



Fig. 9.u: 18 channels piezo emission rack





**For more information on this chapter,  
please visit these pages:**

[cedrat-tec.com/products/evaluation-kits](http://cedrat-tec.com/products/evaluation-kits)

[cedrat-tec.com/products/piezo-motors](http://cedrat-tec.com/products/piezo-motors)

## 10. MECHATRONIC SOLUTIONS

CEDRAT TECHNOLOGIES (CTEC) also proposes different types of complete mechatronic solutions:

- Evaluation and development kits
- Turnkey mechatronic modules

The mechatronic kits can be seen as first plug and play solutions to discover and to practice different aspects of piezo mechatronic for different purposes. For instance, are presented in the following paragraphs:

- the Evaluation Pack **EP120S**: for low cost access and practice of piezo actuator & driver
- the Active Control of Vibration **ACV educational kit**: a set up for educational purpose
- the Linear Stepping Piezo Actuator **LSPA30uXS**, Linear Stepping Piezo Stage **LSPS35XS** and Modular Stepping Piezo Actuator **MSPA35XS** developments kits: three kits to experience miniaturised SPA motors with various integration levels combined with their associated Stepping Piezo Controller SPC45.

## 10.1. EVALUATION PACK EP120S



Fig. 10.a: Evaluation Pack EP120S:  
 APA120S actuator & CAu10 amplifier

The Evaluation Pack provides with an easy evaluation of CEDRAT TECHNOLOGIES's (CTEC) piezo offer in quasi static conditions. It includes:

- An Amplified Piezoelectric Actuator APA120S
- A linear amplifier CAu10
- Related cables

The APA120S can bear load up to 0.5 kg over 140  $\mu\text{m}$ , in a compact size.

The CAu10 can deliver a voltage up to 150 V and has 2 channels.

Please refer to the datasheet of APA120S actuator and CAu10 amplifier for technical specifications and drawings.

The typical diagram stroke/frequency of the EP120S is presented in Fig. 10.b:

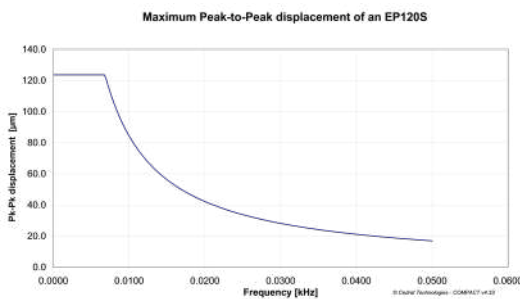

Fig. 10.b: Stroke / frequency of the EP120S

The main features enlightened by the evaluation pack are:

- A high stiffness of the actuator
- A nanometer resolution
- A good repeatability
- An excellent reliability
- An easy implementation
- A low cost of ownership



## 10.2. EDUCATIONAL KIT ACV - ACTIVE CONTROL OF VIBRATIONS

A real opportunity for students to discover mechatronics, control and piezoelectricity.

The education kit ACV (Active Control of Vibration) includes:

- A beam equipped with an accelerometer at the tip
- A magnetic exciter able to move the beam on a large bandwidth
- Related cables

In the actual industry, a growing number of enquiries deals with mechatronics and particularly Active Control of Vibrations. Stabilisation of wafers during lithography process, noise reduction of helicopter blades, elimination of motion blur in optical devices, damping of machine tool vibrations... are few examples of industrial applications.

The kit contains an original and innovative APA®, patented technology from CTEC attached to a mechanical beam. When the beam is excited by the magnetic shaker, the vibrations are measured with an accelerometer. The control is realised with an industrial driver & controller from CTEC using variable PID parameters and output filters. The controller drives the piezo actuator in order to cancel the vibrations of the beam. The result is very visual and impressive!

Developed with CETIM, a centre of excellence in mechanics, SUPMECA and Polytech Annecy-Chambéry, two recognised engineering schools, it fits the curricula of many engineering courses, especially the ones in the forefront of mechanics, mechatronics, control systems and industrial data processing. Control parameters are directly available to students.

Several practical works from 4 to 8 hours developed by teachers are available for download on [cedrat-tec.com/mechatronic-products/evaluation-kits/educational-kit-acv](http://cedrat-tec.com/mechatronic-products/evaluation-kits/educational-kit-acv). It is easy and fast to set up. The treated topics are required know how for engineers: system analysis, PID control, signal post treatment, modal analysis...

Similarly to the whole range of products of CTEC, the kit is extremely robust. It is well protected against mishandlings which relieves students and teachers when using the material.

The educational kit received the first price in the University Challenge 2011 organised by Bruel&Kjaer for the project relative to "Study and control of the vibration behaviour of a ski".



Fig. 10.c: Educational kit ACV

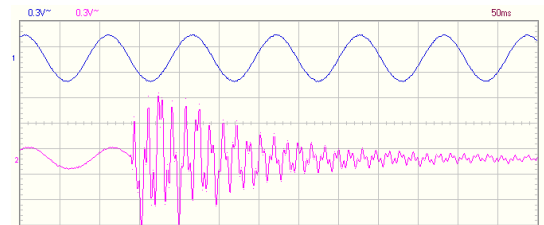

Fig. 10.d: Vibration damping with ACV kit

## 10.3. PIEZO MOTOR DEVELOPER KITS

### 10.3.1. LSPA30UXS PIEZO MOTOR DEVELOPER KIT

The LSPA30uXS (Linear Stepping Piezo Actuator) developer kit offers the possibility to discover the potential of the LSPA30uXS, the smallest existing LSPA, in stepping mode. The developer kit is a plug and play solution. It allows to learn quickly how to use the LSPA motor.

With the included small driver (Stepping Piezo Controller SPC45) and a high resolution magnetic sensor, the developer kit is a fully closed-loop solution allowing a high resolution millimeter-stroke motion (see §8.3.1, page 116 for more information on the piezo controller itself).

The LSPA30uXS developer kit is made of the following items (Fig. 10.e):

- LSPA30uXS on platform: LSPA30uXS mounted on 30×25 mm platform and coupled with a 2 μm resolution position sensor
- SPC45 driver
- SPC45 power supply
- Cables
- USB cable for GUI control on PC

LSPA30uXS performances when coupled with SPC45 are presented in *Table 10.a*. The LSPA30uXS motor can be extracted from the holding platform and integrated directly onto the user's test bench. LSPA30uXS characteristics can be found in §6.1, page 84.

### 10.3.2. LSPS35XS PIEZO MOTOR DEVELOPER KIT

The LSPS35XS (Linear Stepping Piezo Stage) developer kit offers the possibility to discover the potential of the LSPS35XS stage in stepping mode.

The LSPS35XS stage is a guided stage, which includes a position sensor and easy mechanical interfaces (see §6.2, page 6.2). Using the included small driver (SPC45), this kit is a fully closed-loop solution for high resolution millimeter-stroke motion (see §8.3.1, page 116 for more information on the piezo controller itself).

The LSPS35XS developer kit is made of different sub-systems (Fig. 10.g):

- LSPS35XS piezoelectric stage
- SPC45 driver
- SPC45 Power Supply
- Cables
- USB cable for GUI control

LSPS35XS performances when coupled with SPC45 are presented in *Table 10.a*.



Fig. 10.e: Components of the LSPA30uXS developer kit



Fig. 10.f: LSPA30uXS



Fig. 10.g: Components of the LSPS35XS developer kit



Fig. 10.h: LSPS35XS

### 10.3.3. MSPA35XS PIEZO MOTOR DEVELOPER KIT

The MSPA35XS (Modular Stepping Piezoelectric Actuator) developer kit offers the possibility to discover the flexibility of the MSPA piezoelectric motors in stepping mode.

The MSPA35XS developer kit includes a standard MSPA35XS piezoelectric stage combined with a small driver (SPC45). When pressed against a guided payload, the MSPA35XS generates a driving force making it moving.

The MSPA35XS developer kit is made of different sub-systems (Fig. 10.i):

- MSPA35XS piezoelectric stage
- SPC45 driver
- SPC45 power supply
- Cables
- USB cable for GUI control

MSPA35XS performances when coupled with SPC45 are presented in Table 10.a.

A typical example that can be achieved using the MSPA35XS developer kit is to drive a commercial bearing as shown in Fig. 10.k.



Fig. 10.i: Components of the MSPA35XS developer kit

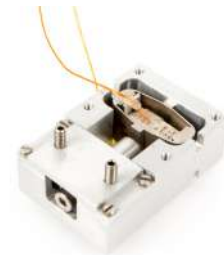

Fig. 10.j: MSPA35XS

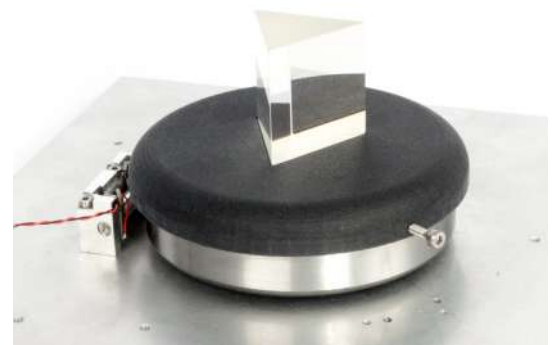

Fig. 10.k: Example of MSPA35XS use

PARAMETER	UNIT	LSPA30UXS	LSPS35XS	MSPA35XS
<b>&gt; Stepping mode</b>				
Travel range	mm	3.4	10	$\infty$ (a.1)
Nominal Speed (a.2) (a.3)	mm/s	20	10	10
Typical step size (a.2) (a.3)	$\mu\text{m}$	5 ... 30		5 ... 20
Stiffness	N/ $\mu\text{m}$	0.09		0.50
<b>&gt; Forces</b>				
Holding force without consumption	N	0.8		3
Nominal driving force (a.2) (a.3)	N	0.2	0.8	0.5
<b>&gt; Driver</b>				
Nominal driver			SPC45	

Table 10.a

Characteristics of developer kits coupled with SPC45

a.1 Limited by moving part

a.2 Unloaded

a.3 With nominal driver

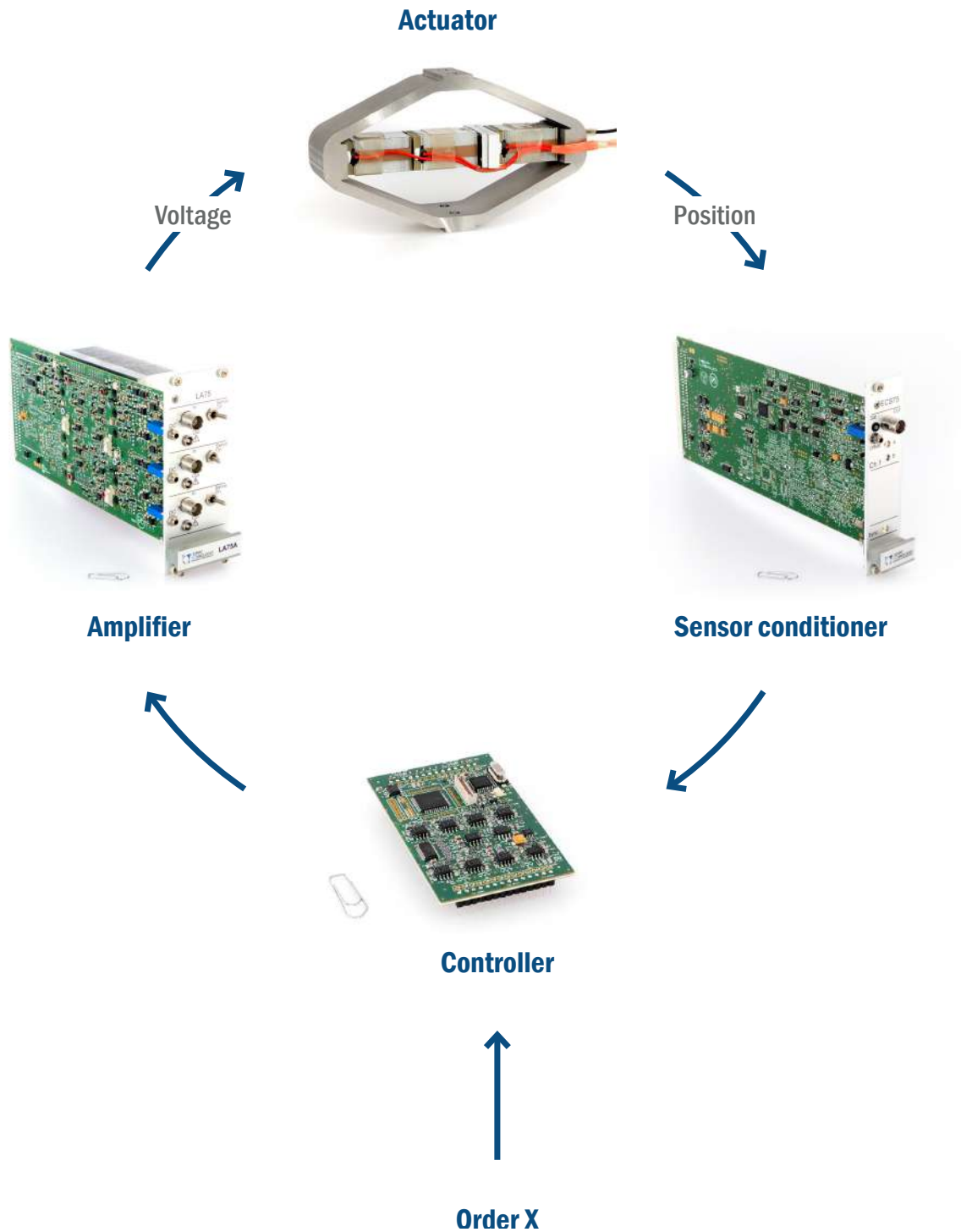

**For more information on this chapter,  
please visit these pages:**

[www.cedrat-technologies.com](http://www.cedrat-technologies.com)

[cedrat-tec.com/products/users-manual/electronics](http://cedrat-tec.com/products/users-manual/electronics)

# 11. APPLICATION NOTES

## 11.1. YOUR OWN APPLICATION SELECTION GUIDE

CEDRAT TECHNOLOGIES (CTEC) can help you select the right combination of actuator and driver. Try to answer the following questions and share your specifications by email or by phone.

- Maximum **displacement** required for my application
- Required **bandwidth** (At which frequency do I want to drive the actuator ?)
- Required **actuation time**
- **Size** (What volume and dimensions are allowed for the actuator in my application ?)
- **Mass to be moved** by the actuator (What is the inertia ?)
- **Forces acting** on the actuator:
  - Spring loading (Is my actuator loaded by a spring? What is the spring's stiffness?)
  - Presence of other forces like gripping, viscosity, etc...?
- **Position sensor** (Do I need to monitor and/or control the motion/ the position?)
- Motion **resolution** required
- Motion **accuracy** required
- **Environment:**
  - Temperature range
  - Humidity
  - Vacuum
  - Vibration shock
  - Magnetic field compatibility

See *Table 11.a* and *Table 11.b* next page for electronic selection.

ELECTRONIC SERIE	CAU10	CCBU20	LA75A	LA75B	LA75C	SA75A	SA75B	SA75D	
Continuous peak output current (mA)	5	200	90	360	2 400	5 000	10 000	20 000	
Transient peak output current (mA)	-	-	300	1 100	8 000	-	-	-	
ACTUATOR SERIE	CAPACITANCE (µF)	CHARGING TIME @ 170 V (MILLISECONDS) <sup>(A.1)</sup>							
<b>&gt; MLA serie</b>									
MLA 2×5×10	0.25	8.5	0.2	0.14	0.04	0.01	0.15	0.15	0.15
MLA 5×5×10	0.7	24	0.6	0.4	0.11	0.01	0.15	0.15	0.15
MLA 5×5×20	1.55	53	1.3	1.5	0.2	0.03	0.15	0.15	0.15
MLA 10×10×20	6.6	224	6	11.1	1.9	0.1	0.25	0.2	0.18
MLA 14×14×20	12	408	10	21.3	4.4	0.3	0.4	0.27	0.23
<b>&gt; APA® serie</b>									
APA - µXS	0.052	1.8	0.04	0.03	0.01	0.001	0.15	0.15	0.15
APA - XXS	0.15	5.1	0.1	0.09	0.02	0.003	0.15	0.15	0.15
APA - XS	0.25	8.5	0.2	0.1	0.04	0.01	0.15	0.15	0.15
APA - S, SM	1.55	53	1.3	1.5	0.2	0.03	0.15	0.15	0.15
APA - M	3.15	107	2.7	4.6	0.5	0.1	0.15	0.15	0.15
APA - MML	10	340	8.5	17.5	3.5	0.2	0.35	0.25	0.22
APA - ML	20	680	17	36.4	8.2	0.4	0.58	0.38	0.28
APA - L	40	1 360	34	74.2	17.7	1.4	1.2	0.67	0.42
APA - XL	110	3 740	94	206	50.7	6.4	4	1.83	0.88
<b>&gt; PPA serie</b>									
PPA10M	0.7	24	0.6	0.4	0.11	0.01	0.15	0.15	0.15
PPA20M	1.4	48	1.2	1.2	0.2	0.03	0.15	0.15	0.15
PPA40M	2.7	92	2.3	3.7	0.4	0.1	0.15	0.15	0.15
PPA40L	13.3	452	11	24	5	0.3	0.42	0.29	0.24
PPA60L	20	680	17	36	8.2	0.4	0.58	0.38	0.28
PPA80L	26.6	904	23	49	11	0.6	0.72	0.46	0.33
PPA40XL	24	816	20	44	10	0.5	0.67	0.43	0.31
PPA80XL	48	1 632	41	89	21	2.0	1.52	0.8	0.47
PPA120XL	72	2 448	61	135	33	3.7	2.48	1.2	0.63

 Table 11.a Charging time comparison between drivers<sup>(a.2)</sup>

a.1 Values computed according to transient peak output current / See EPC application note

a.2 Warning these values are given for electrical limitation. Thermal and mechanical limitations of the actuator are not taken into account

ELECTRONIC SERIE	CAU10	CCBU20	LA75A	LA75B	LA75C	SA75A	SA75B	SA75D	
Continuous peak output current (mA)	5	200	90	360	2 400	5 000	10 000	20 000	
Transient peak output current (mA)	-	-	300	1 100	8 000	-	-	-	
ACTUATOR SERIE	CAPACITANCE (µF)	MAXIMUM FREQUENCY (SINUS) @ 170 VPP (HZ) <sup>(B.1)</sup>							
<b>&gt; MLA series</b>									
MLA 2×5×10	0.25	40	300	670	2 700	17 980	- (b.2)	- (b.2)	- (b.2)
MLA 5×5×10	0.7	10	110	240	960	6 420	- (b.2)	- (b.2)	- (b.2)
MLA 5×5×20	1.55	10	50	110	430	2 900	- (b.2)	- (b.2)	- (b.2)
MLA 10×10×20	6.6	1.4	10	26	100	680	1 420	2 840	- (b.2)
MLA 14×14×20	12	0.8	10	14	56	370	780	1 560	3 120
<b>&gt; APA<sup>®</sup> serie</b>									
APA - µXS	0.052	180	1440	3 240	12 960	- (b.2)	- (b.2)	- (b.2)	- (b.2)
APA - XXS	0.15	62	500	1 120	4 490	29 960	- (b.2)	- (b.2)	- (b.2)
APA - XS	0.25	37	300	670	2 700	17 980	- (b.2)	- (b.2)	- (b.2)
APA - S, SM	1.55	6	50	110	430	2 900	- (b.2)	- (b.2)	- (b.2)
APA - M	3.15	3	20	53	210	1 430	2 970	- (b.2)	- (b.2)
APA - MML	10	1	10	17	67	450	940	1 870	3 740
APA - ML	20	0.5	4	8	34	220	470	940	1 870
APA - L	40	0.2	2	4.2	17	110	230	470	940
APA - XL	110	0.1	1	1.5	6	40	90	170	340
<b>&gt; PPA serie</b>									
PPA10M	0.7	10	110	240	960	6 420	- (b.2)	- (b.2)	- (b.2)
PPA20M	1.4	10	50	120	480	3 210	- (b.2)	- (b.2)	- (b.2)
PPA40M	2.7	3	30	60	250	1 660	3 470	- (b.2)	- (b.2)
PPA40L	13.3	1	10	13	51	340	700	1 410	2 820
PPA60L	20	0.5	4	8	34	220	470	940	1 870
PPA80L	26.6	0.4	3	6	25	170	350	700	1 410
PPA40XL	24	0.4	3	7	28	190	390	780	1 560
PPA80XL	48	0.2	2	3.5	14	90	200	390	780
PPA120XL	72	0.1	1	2.3	9	60	130	260	520

Table 11.b Maximum frequency comparison between drivers<sup>(b.3)</sup>

b.1 Values computed according to continuous peak output current

b.2 Please contact CTEC for this configuration

b.3 Warning these values are given for electrical limitation. Thermal and mechanical limitations of the actuator are not taken into account

## 11.2. BUILDING A GENERAL PIEZOELECTRIC ACTUATOR MODEL

The principal task before controlling a piezo actuator is to build a model integrating the parameters of the actuator from the catalogue. This model allows the tuning of the controller's parameters in advanced processes or for an optimal control. Several parameters are given inside and recalled below:

- **Stroke:**  $\Delta U$  (m).
- **Voltage:**  $V$  (V), output voltage provided by the electronic amplifier on the piezo actuator.
- **Voltage:**  $V_{max}$  (V) maximal voltage applied on the piezo actuator to reach the maximal stroke.
- **Blocked force:**  $F_0$  (N), maximum force generated by the actuator with no displacement at maximum voltage  $V_{max}$
- **Force factor:**  $N$  (N/V), force per voltage unit:

$$N = \frac{F_0}{V_{max}}$$

- **Stiffness:**  $K$  (N/m), displacement  $\Delta U$  under an applied force  $F$ :

$$K = \frac{F_0}{\Delta U_0}$$

Elasticity is the opposite of stiffness:

$$c_m = \frac{1}{K}$$

$C_m$  can be seen as equivalent capacitance in the motional equivalent circuit.

- **Effective Mass:**  $M+m$  (Kg) actuator mass plus additional embedded mass
- **Resonant frequency:**  $f_r$  (Hz) first mode computed with the stiffness and effective mass:

$$f_r = \frac{1}{2\pi} \sqrt{\frac{K}{M+m}}$$

- **Quality factor:**  $Q$  indicates a rate of energy dissipation relative to the oscillation frequency:

$$Q_m = \frac{1}{2\pi f_r c_m r_m}$$

$r_m$  is the resistance in the motional equivalent circuit. The quality factor of piezo actuators depends on signal amplitude and boundary condition and then can vary from 20 to higher than 100.

From these parameters and as the actuator is driven in voltage the transfer function of this continuous plant can be written:

$$TF(j\omega) = \frac{\Delta U}{V} = \frac{N c_m}{(1 + j\omega r_m c_m - \omega^2 c_m (M + m))}$$

The generic model is a second order filter with high quality factor. When multi mode mechanisms are used, the plant must contain each mode built with the same formulae. Of course, this model is a rough model excluding the nonlinearities of the piezo actuator such as the hysteresis, the creep effect and other non linear effects. Nevertheless, this model can be used to design the control loop.



### 11.3. POSITIONING CONTROL OF PIEZO ACTUATORS

Once you have built your actuator model, the next step is to build your control strategy. Most of piezo actuator's applications require a closed loop positioning control based on a positioning sensor (Strain gages, Contactless position sensor, etc...) feedback and a controller including filters and regulator or specific algorithm. This position control is mandatory to get rid-off the multiple non-linear effects of a piezo actuator such as hysteresis, creep, gain variation with temperature, etc... in order to achieve a high level of positioning accuracy, repeatability and stability required by the user system.

In terms of control strategy, Cedrat Technologies (CTEC) can propose its digital control board with various control solutions from the standard PID linear regulator (see Fig. 11.a) to the most sophisticated non linear algorithm in order to satisfy different motion control demands met in micro-scanning, tracking and stabilisation functions to name but a few. For basic control solution of piezo actuators based on PID regulator and filters, CTEC published the application note below in order to help the user to optimise and to make the control parameters more robust. It is based on the HDPM GUI proposed in the standard UC product.

See application note on position control of piezo actuators:

[cedrat-tec.com/products/users-manual/electronics.html](http://cedrat-tec.com/products/users-manual/electronics.html)

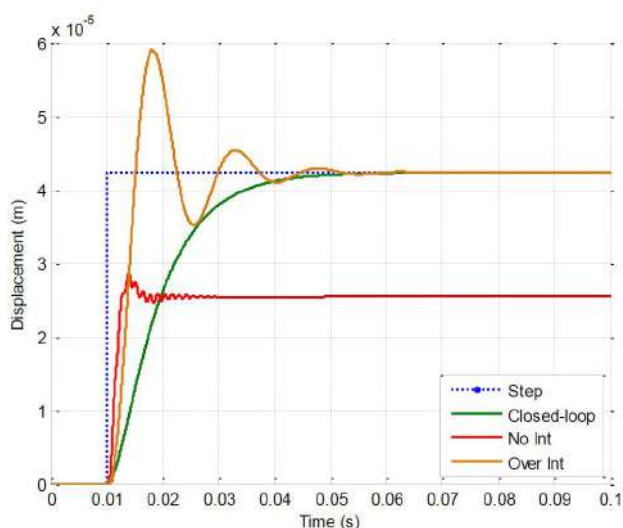

Fig. 11.a: Step response of a piezo actuator with and without optimised PID closed loop

## 11.4. EPC: ENHANCED PEAK CURRENT

In the upgraded LA75 product a new function called Enhanced Peak Current is added to fast charge actuators actuators.

An enhanced peak current capability for LA75 series allows faster actuator charging thanks to a larger output current during a limited time. This feature increases the power bandwidth as well for low repetition rate signals.

A piezo charge is like a capacitor. Due to this behavior, driving at large frequency demands large currents from the specific driver:

$$I_{piezo}(t) = C_{piezo} \times \frac{dV(t)}{dt}$$

CTEC has developed a solution able to provide more current during short time to respond to this problematic. A dedicated Application Note is proposed to understand the details of the behavior of such electronic capability in regards of your need.

See application note on Enhanced peak current for linear amplifiers :

[cedrat-tec.com/products/users-manual/electronics.html](http://cedrat-tec.com/products/users-manual/electronics.html)

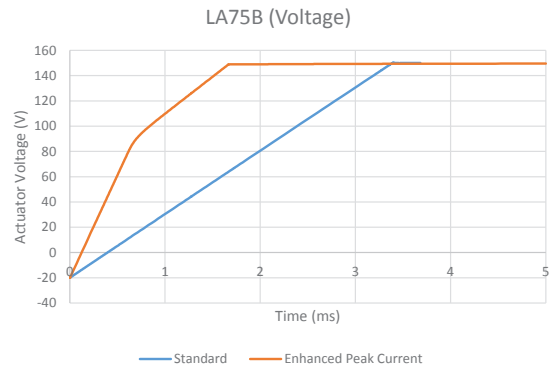

Fig. 11.c: Actuator's voltage with and without peak current capability

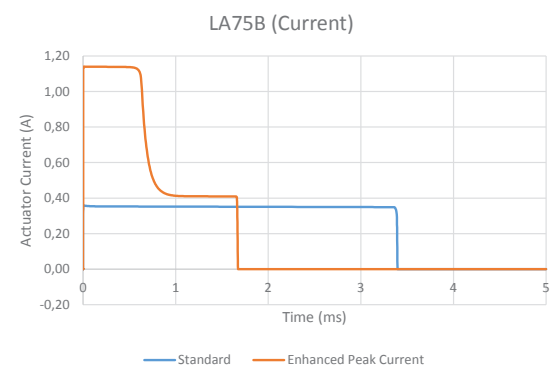

Fig. 11.b: Actuator's current with and without peak current capability





## INDEX

**Accuracy, relative and absolute:**  
§ 11.3 p.143

**Amplified Piezoelectric Actuators (APA®):**  
§ 1.3.2 p.10;  
§ 4.2 p.60

**Amplifier:**  
§ 8.1 p.102;  
§ 8.2 p.112

**Blocked force:**  
§ 11.2 p.142

**Charging time:**  
§ 2.1.10 p.25

**Controller:**

- **CCB:**  
§ 8.1.1 p.102
- **UC55:**  
§ 8.1.6 p.110

**LC converter:**  
§ 8.1.2 p.104;  
§ 8.1.3 p.106

**Current limitation:**  
§ 2.1.10 p.25;  
§ 2.2.8 p.34

**Drift or creep:**  
§ 2.1.10 p.25;  
§ 11.2 p.142;  
§ 11.3 p.143

**Effective mass  $M_{eff}$ :**  
§ 2.1.8 p.21;  
§ 11.2 p.142

**FAPS:**  
§ 5.8 p.80

**FPS:**  
§ 5.7 p.80

**Force limitation:**  
§ 2.1.9 p.22;  
§ 2.1.10 p.25

**FSPA:**  
§ 6.5 p.88

**Life time:**  
§ 2.1.9 p.22

**Multilayer Actuators (MLA):**  
§ 4.3 p.70

**MSPA:**  
§ 6.3 p.86

**Operation modes:**

- **Dynamic strain (DS):**  
§ 2.1.9 p.22;  
§ 3.2 p.45
- **Dynamic force (DF):**  
§ 2.1.9 p.22;  
§ 3.2 p.45
- **Static (S):**  
§ 2.1.9 p.22;  
§ 3.2 p.45
- **Impulse:**  
§ 2.1.9 p.22;  
§ 3.2 p.45
- **Quasi-static:**  
§ 2.1.8 p.21;  
§ 2.1.9 p.22;  
§ 2.1.10 p.25
- **Resonant (R):**  
§ 2.1.8 p.21;  
§ 11.2 p.142

**Parallel Pre-stressed Actuators (PPA):**  
§ 1.3.1 p.10;  
§ 4.4 p.71

**Preliminary data:**  
§ 3.1 p.43

**Pre-load & pre-stress:**  
§ 2.1.9 p.22

**Proof-Mass Actuators (PMA):**  
§ 3.2.4 p.51

**Repeatability:**  
§ 11.3 p.143

**Resonance frequency:**

- **Free-free:**  
§ 2.1.9 p.22
- **Blocked-free:**  
§ 2.1.9 p.22

**Settling time:**  
§ 2.1.8 p.21;  
§ 2.1.10 p.25

**Stepping Piezo Stage (SPS):**  
§ 6.2 p.85

**Stepping Piezo Actuators (SPA):**  
§ 1.3.3 p.10;  
§ 6.1 p.84;  
§ 6.4 p.87;  
§ 6.3 p.86;  
§ 6.5 p.88

**Stiffness:**  
§ 2.1.5 p.18;  
§ 2.1.7 p.20;  
§ 11.2 p.142

**Stroke:**  
§ 11.2 p.142

Even though CEDRAT TECHNOLOGIES S.A. makes every effort to guarantee the accuracy of the content of its catalogue, the information may be incomplete or, technically inaccurate or may contain typographical errors. Accordingly, the information provided may be corrected or changed by CEDRAT TECHNOLOGIES SA at any time and without prior notice.

CEDRAT TECHNOLOGIES S.A. may, at any time and without prior notice, change or improve the products and services offered. CEDRAT TECHNOLOGIES S.A. disclaims all liability for any information, inaccuracy or omission in its catalogue. CEDRAT TECHNOLOGIES S.A. shall bear no liability for any decision made on the basis of the said information.

The reproduction or use of the information (texts, pictures, diagrams ...) published by CEDRAT TECHNOLOGIES S.A. in this catalogue is authorised solely for personal and private use. Any reproduction or use of this information for other purposes is strictly prohibited.

All rights reserved © Copyright February 2023

CEDRAT TECHNOLOGIES S.A. - Meylan, France.

# NOTES







CEDRAT TECHNOLOGIES (CTEC) offers off-the-shelf mechatronics products including piezoelectric & magnetic actuators, motors, mechanisms, transducers and sensors with corresponding drivers & controllers. These mechatronics products are used for scientific and industrial applications requiring functions such as: micro and nano positioning, generation of vibrations, micro-scanning, fast & precise motion control, active control of vibrations, and energy harvesting...

Most of the products are available in OEM versions for low cost and high volume industrial applications. CTEC also offers services including, design, R&D under contract and training.

CTEC is a SME located in Meylan, Inovallée, the French Innovation Valley near Grenoble. CTEC is recognised as a highly innovative company and has received several awards.

**CEDRAT TECHNOLOGIES**

59 Chemin du Vieux Chêne - Inovallée  
38246 Meylan Cedex

+33 (0)4 56 58 04 00

[www.cedrat-technologies.com](http://www.cedrat-technologies.com)

