

ULTRASONIC MOTOR

USR45-V
(VACUUM TYPE)

DIMENSIONS

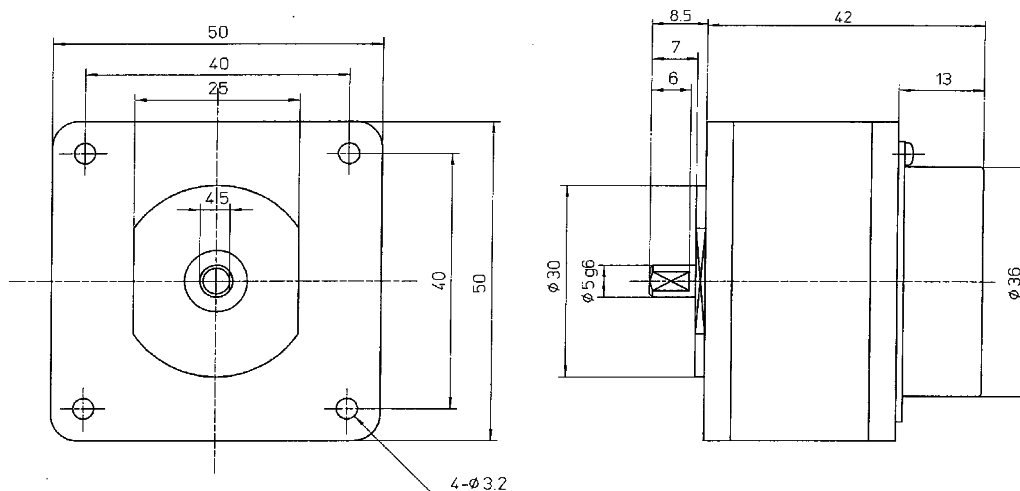

SPECIFICATION

MOTOR	RATED TORQUE (Nm)	0.2
	RATED SPEED (S^{-1})	min. 1.5
	RATED OUTPUT (W)	min. 1.9
	HOLDING TORQUE (Nm)	min. 0.2
	WEIGHT (g)	250
	ENCODER RESOLUTION (P/R)	800
DRIVER	INPUT VOLTAGE (V)	DC12 \pm 0.5
	INPUT CURRENT (A)	max. 3.0
	WEIGHT (g)	about 1,100
OPERATING TEMPERATURE RANGE		-10 \sim 50 $^{\circ}$ C
STORAGE TEMPERATURE RANGE		-20 \sim 60 $^{\circ}$ C

CHARACTERISTIC

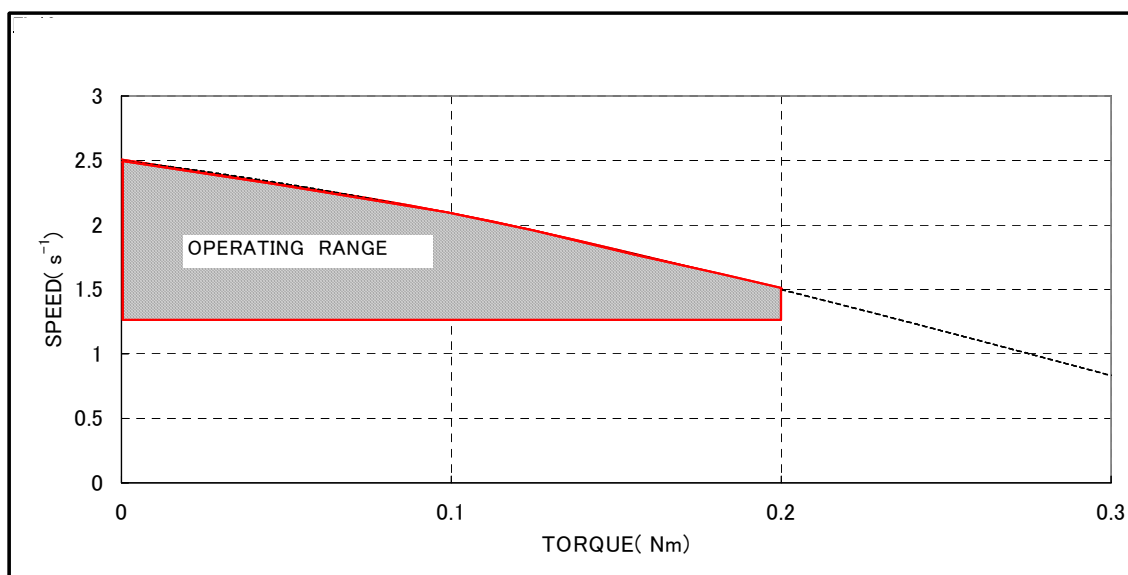

 **FUKOKU**

Fukoku Co., Ltd.