

ULTRASONIC MOTOR

USR45-E
(TYPE WITH ENCODER)

DIMENSIONS

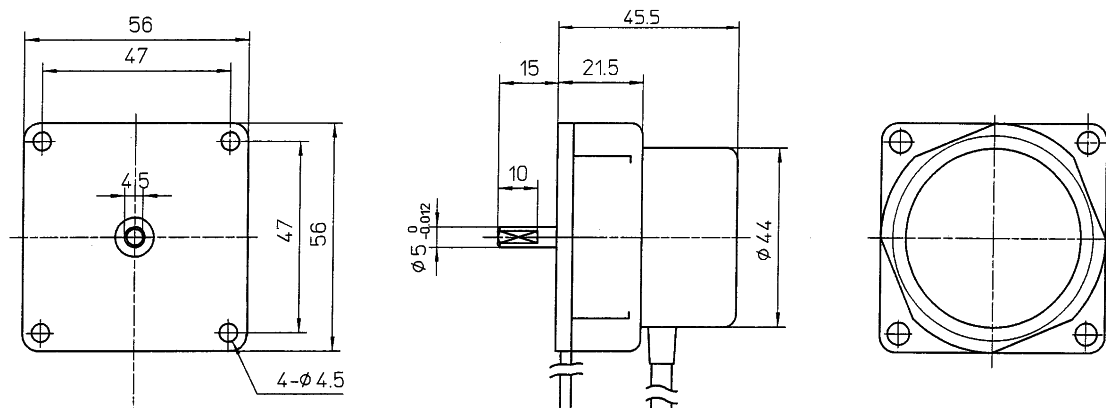

SPECIFICATION

MOTOR	RATED TORQUE (Nm)	0.118
	RATED SPEED (S^{-1})	min. 2.17
	RATED OUTPUT (W)	min. 1.5
	HOLDING TORQUE (Nm)	min. 0.118
	WEIGHT (g)	210
	ENCORDER RESOLUTION (P/R)	1,000
DRIVER	INPUT VOLTAGE (V)	DC12 \pm 0.5
	INPUT CURRENT (A)	max. 2.0
	WEIGHT (g)	about 550
OPERATING TEMPERATURE RANGE		-10 \sim 50 $^{\circ}C$
STORAGE TEMPERATURE RANGE		-20 \sim 60 $^{\circ}C$

CHARACTERISTIC

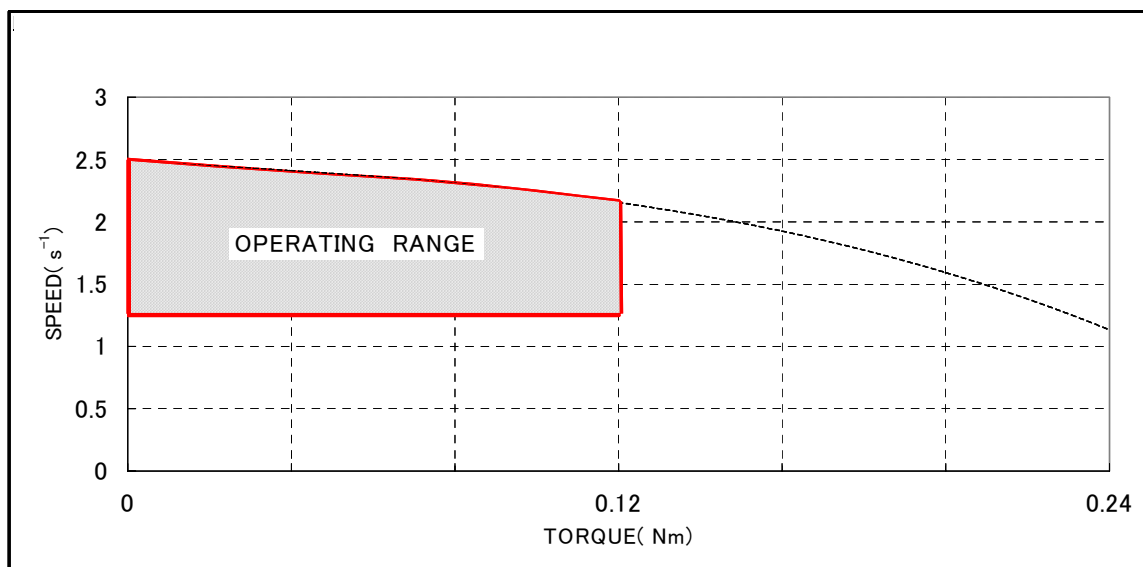

 **FUKOKU**

Fukoku Co., Ltd.