

# ULTRASONIC MOTOR

USR30-S2

## DIMENSIONS

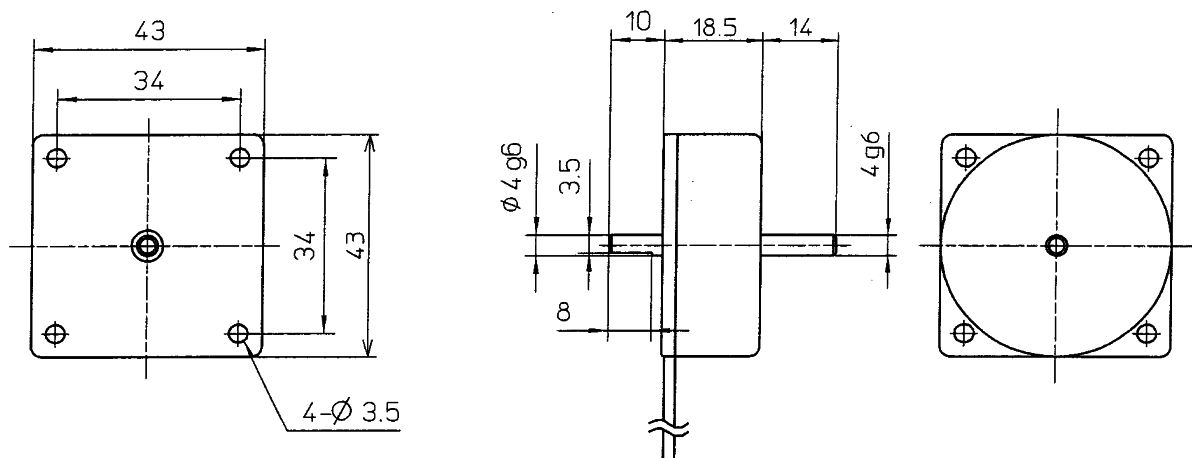

## SPECIFICATION

MOTOR	RATED TORQUE (Nm)	$2.9 \times 10^{-2}$
	RATED SPEED ( $s^{-1}$ )	min. 3.83
	RATED OUTPUT (W)	min. 0.7
	HOLDING TORQUE (Nm)	min. $2.9 \times 10^{-2}$
	WEIGHT (g)	50
	ENCORDER RESOLUTION (P/R)	—
DRIVER	INPUT VOLTAGE (V)	DC $12 \pm 0.5$
	INPUT CURRENT (A)	max. 1.0
	WEIGHT (g)	about 240
OPERATING TEMPERATURE RANGE		$-10 \sim 50^{\circ}C$
STORAGE TEMPERATURE RANGE		$-20 \sim 60^{\circ}C$

## CHARACTERISTIC

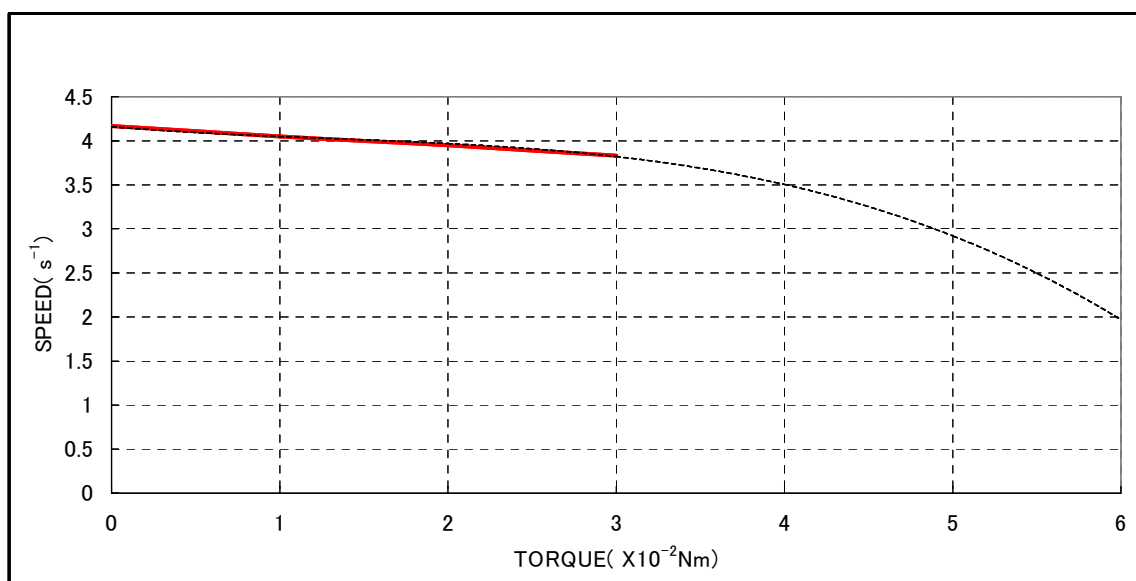

**FUKOKU**

Fukoku Co., Ltd.