

ULTRASONIC MOTOR

USR30-E
(TYPE WITH ENCODER)

DIMENSIONS

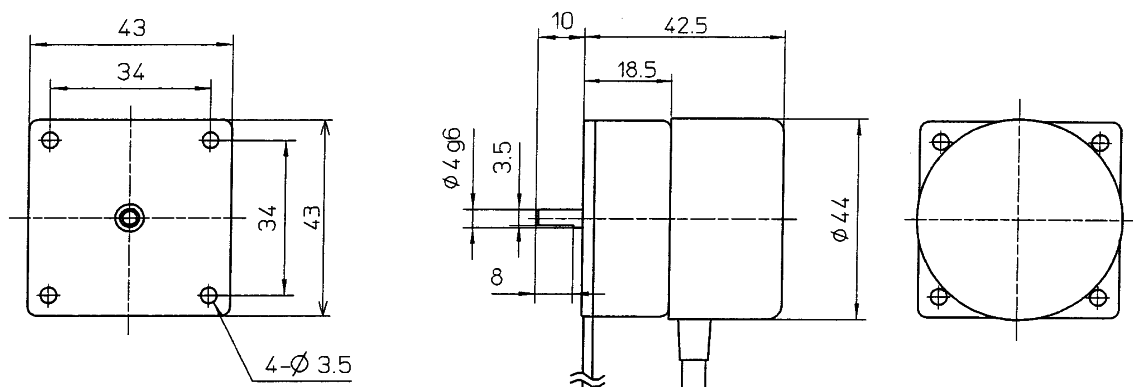

SPECIFICATION

MOTOR	RATED TORQUE (Nm)	2.9×10^{-2}
	RATED SPEED (S^{-1})	min. 3.83
	RATED OUTPUT (W)	min. 0.7
	HOLDING TORQUE (Nm)	min. 2.9×10^{-2}
	WEIGHT (g)	150
	ENCORDER RESOLUTION (P/R)	1,000
DRIVER	INPUT VOLTAGE (V)	DC 12 ± 0.5
	INPUT CURRENT (A)	max. 1.5
	WEIGHT (g)	about 550
OPERATING TEMPERATURE RANGE		$-10 \sim 50^{\circ}C$
STORAGE TEMPERATURE RANGE		$-20 \sim 60^{\circ}C$

CHARACTERISTIC

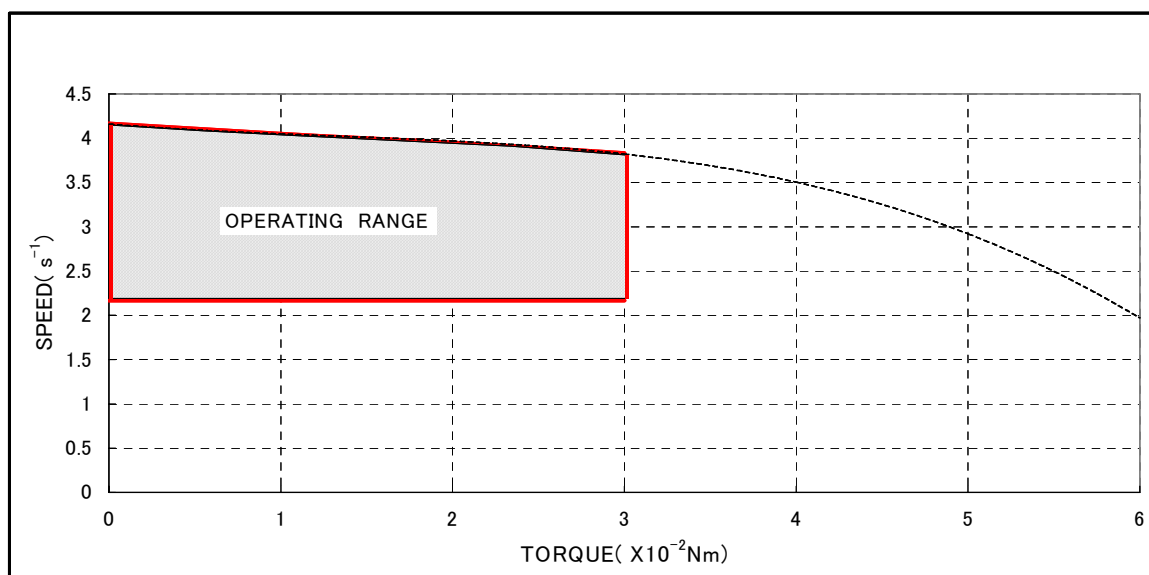

FUKOKU

Fukoku Co., Ltd.