

FS Optical Fiber Stretcher

Datasheet

Revision History

Date	Revision	By	Changes
12/07/2021	R1	BR	Document created
16/02/2020	R4	BR	

Contents

1	Introduction	4
2	Operating Principle	5
3	Experimental Performance.....	6
4	Online Fiber Stretcher Configuration Tool	8
5	Single Mode Fibers	10
6	Polarization Maintaining Fibers.....	11
7	Optical Connectors For OEM	11
8	Electrical Configuration	12
9	Recommend Drivers	13
10	Example Electrical Connections	14
11	Enclosure Front Panel	17
12	Ordering	18
13	Specifications	19
14	Safety Warnings	19
15	Dimensions.....	20
16	Delivery Contents.....	22
17	Warranty	22

1 Introduction

The FS Optical Fiber Stretcher is a highly customizable optical fiber stretcher based on a piezoelectric tube actuator. The selected fiber is wound onto the tube with a controlled tension. During operation, a voltage applied to the piezoelectric tube results in a change in diameter of the tube and a proportional change in the optical path length.

Customizations include the fiber type, number of turns, optical connection type, and electrical drive configuration. Single-mode (SM) and polarization-maintaining (PM) fibers are available. The PiezoDrive FS is available in an enclosure or as OEM version; these are shown in Figure 1. The enclosed option uses two FC/APC optical connectors and is available in two electrical configurations, single-ended or differential.



Figure 1. PiezoDrive fiber stretcher FS in enclosure and as OEM version.

2 Operating Principle

The FS fiber stretcher uses the expansion and contraction of a piezoelectric tube to strain an optical fiber wrapped around the circumference. The change in the tube outside radius is

$$\Delta r = d_{31} \frac{V}{t} \left(r - \frac{t}{4} \right)$$

where, r is the outside radius, t is the thickness of the tube, d_{31} is the piezoelectric strain constant, and V is the applied voltage. The resulting change in circumference is $\Delta c = 2\pi\Delta r$, and the resulting change in fiber length ΔL for N turns is $\Delta L = N\Delta c$. Therefore, the change in the fiber's length is

$$\Delta L = N \frac{2\pi d_{31} V}{t} \left(r - \frac{t}{4} \right)$$

For the FS fiber stretcher with $r = 30\text{mm}$, $t = 1\text{mm}$, $d_{31} = -2.65 \times 10^{-10} \text{ m/V}$, the change in optical path length is approximated by

$$\Delta L \approx NV \times (-50 \text{ nm}).$$

These relationships are shown graphically in Figure 2, where the fiber stretcher undergoes a radial contraction when a positive voltage is applied and a radial expansion when a negative voltage is applied. Since the fiber is wrapped under tension, the contraction experienced during positive voltages does not result in a compressive force being applied to the fiber. Using $50 \text{ nm}/N \text{ V}$ with a maximum voltage of 2500 V , the maximum change in path length is approximately $125 \text{ }\mu\text{m}$ per turn.

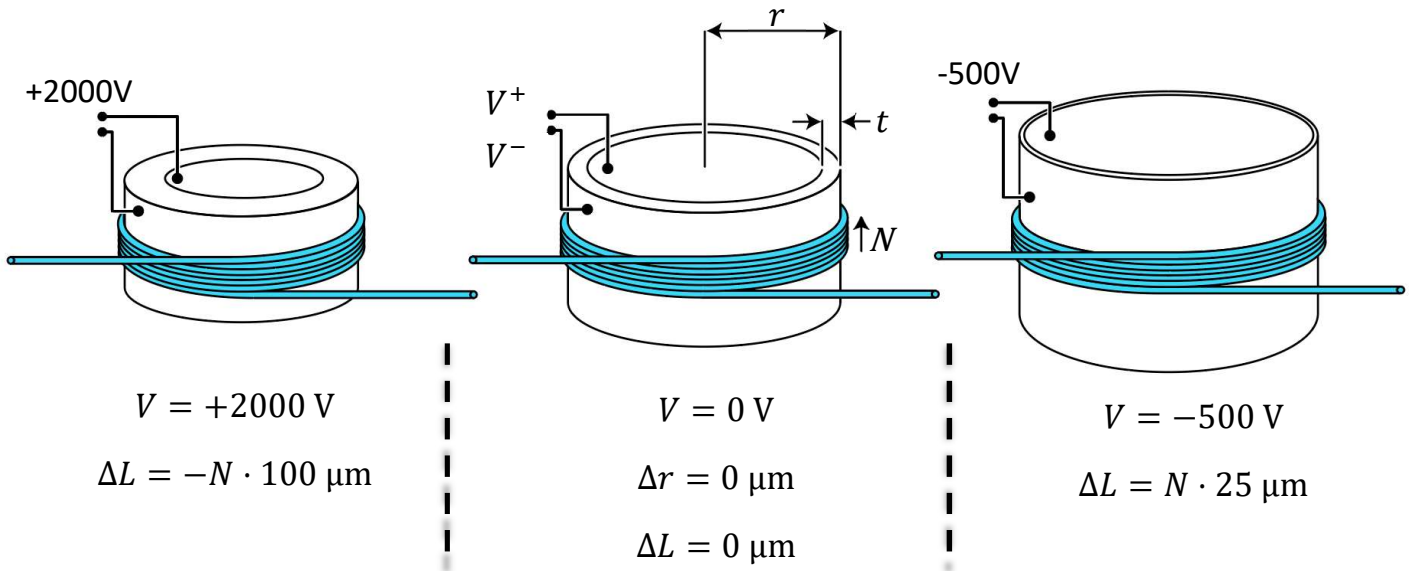

Figure 2. Radial contraction and expansion resulting from positive and negative voltages.

3 Experimental Performance

3.1 Displacement

In the section above, the theoretical change in the fiber' length was determined to be $50 \text{ nm}/N V$. This change in the fiber's length, is not the change in optical path length. To determine the theoretical optical path displacement OPD sensitivity, we must multiply by the refractive index of the optical fiber core. For example, suppose the refractive index is assumed to be 1.4. In that case, the theoretical OPD sensitivity is $70 \text{ nm}/N V$. However, this theoretical sensitivity ignores the optical fiber and glue restraining the piezo tube.

In order to confirm the sensitivity experimentally, a FS optical fiber stretcher with 47 turns was inserted into the measurement arm of a fringe counting Michelson interferometer; the experimental setup is shown in Figure 3. This interferometer used a 632 nm He Ne laser and the piezo tube was driven with a 2 kV voltage supply. The voltage was ramped over approximately 2 seconds, while the interferometer measured the optical displacement. The result of this voltage ramp is shown in Figure 4. The optical path sensitivity for 0 to 500 V is $36 \text{ nm}/N V$, which is the sensitivity used by the online tool and the recommended sensitivity to calculate the number of turns required.

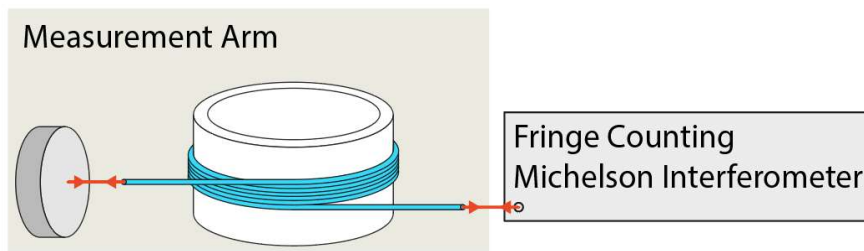

Figure 3: Experimental setup to determine the optical path displacement sensitivity.

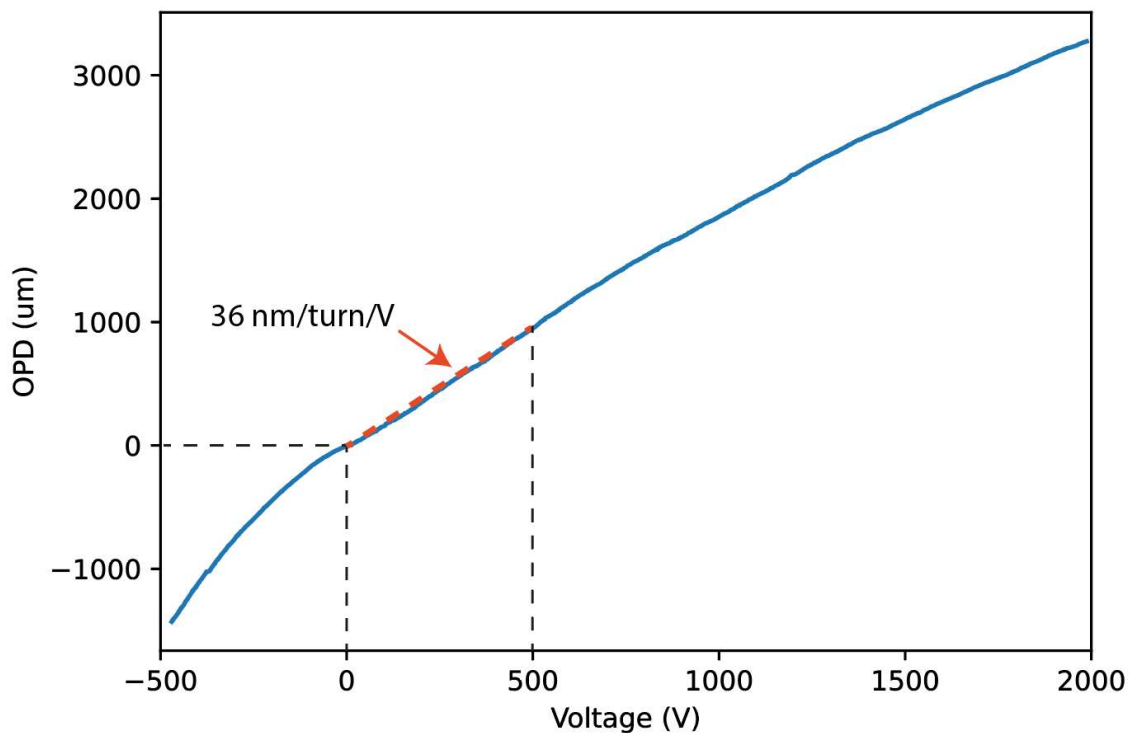

Figure 4: Optical path displacement vs voltage.

3.2 Frequency Response

The frequency response from applied voltage to the piezoelectric tube to optical path displacement was measured by inserting an FS fiber stretcher into the measurement arm of a phase-locked Michelson Interferometer; this setup is shown in Figure 5. It can be seen from the frequency response measurement in Figure 6 that the first resonance occurs at approximately 14.5 kHz, with a flat response up to 10kHz.

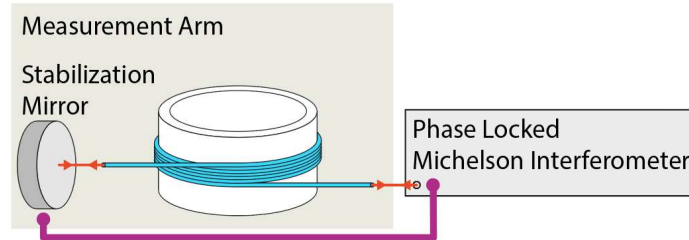

Figure 5: Experimental setup to measure the frequency response.

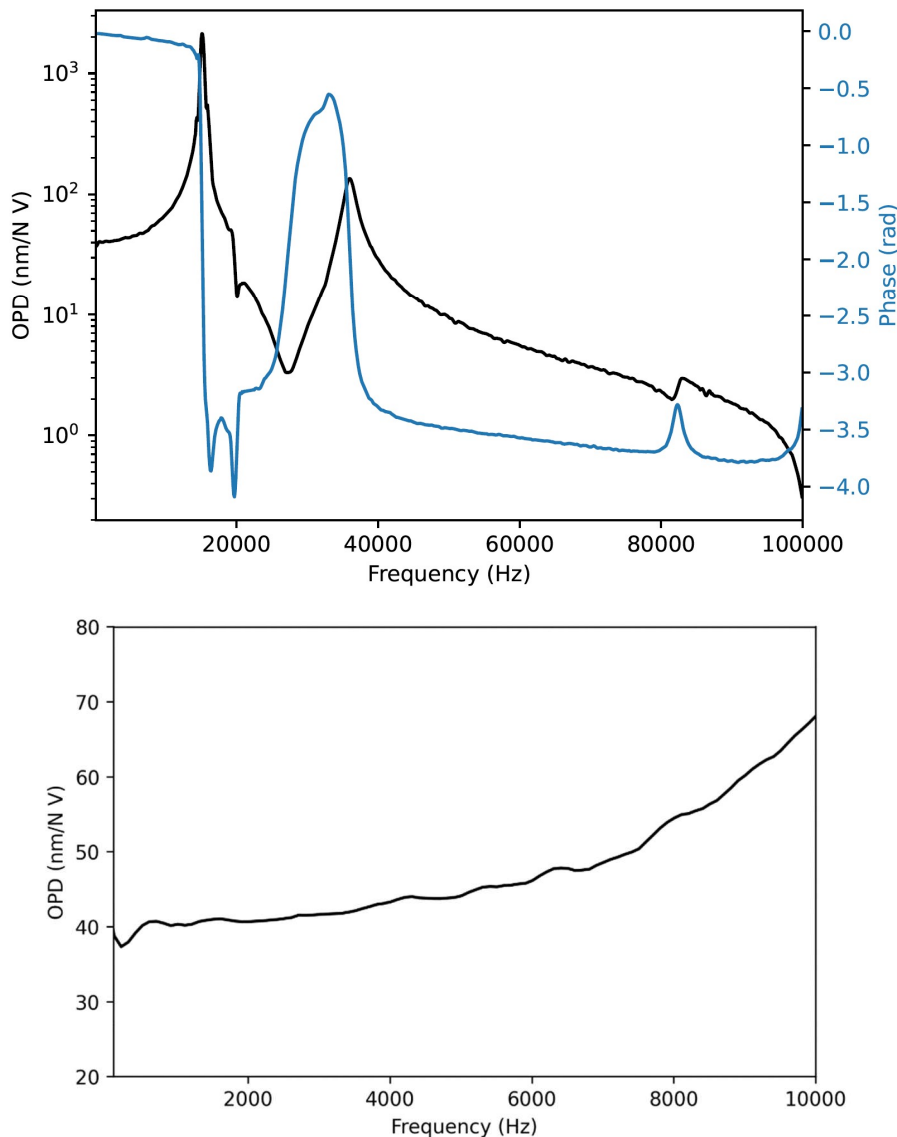

Figure 6: Frequency response from applied voltage to optical path displacement.

4 Online Fiber Stretcher Configuration Tool

The optical path sensitivity was measured to be $36 \text{ nm}/N \text{ V}$, where N can be chosen between 1 and 80 in intervals of 5. Since the maximum change in voltage is 2500 V, the maximum change in path length is approximately 90 μm per turn.

The ideal number of turns is determined by the available voltage range and the required change in path length. To simplify the choice of turns and voltage amplifier, an [PiezoDrive online tool](#) is available which calculates the number of turns, voltage amplifier model, and electrical configuration for a given required displacement and bandwidth. Alternatively, please [contact us](#) for advice on possible fiber stretcher configurations.

4.1 Using the Online Configuration Tool

The configuration tool is available [online](#). The two input variables are the required displacement and maximum operating frequency at full range.

The output of the configuration tool is a list of drivers and electrical configurations. The differential option requires two amplifier channels, which may be constructed from two channels of a multi-channel driver (e.g. TD250 and PD200X4), or from two single-channel drivers (e.g. PX200).

The possible configurations are ranked on suitability and resolution. Each configuration is classed as either:

- **Suitable.** This means that the driver will supply enough current to provide the required displacement at the maximum frequency.
- **Thermally limited.** This means that the tube needs to be driven with a high power to achieve the required displacement. This is suitable for short periods of operation but not continuous operation, which may result in the piezo tube overheating. This issue commonly arises when the required displacement is large and the number of turns is already maximized.
- **Not suitable.** The driver will not supply enough current to provide the required displacement at the stated frequency. This requires more turns or more driver current.

The output information for each configuration includes:

- **Recommended Number of Turns:** the ideal number of turns that meet the requirements for a given driver.
- **Resolution:** the minimum step size of the input, assuming a 16 bit input.
- **Required Voltage:** the voltage recommended to meet the required displacement.
- **Optical displacement at required voltage:** the voltage recommended to meet the required displacement.
- **Maximum continuous operating frequency at required voltage:** continuously operating above this frequency will thermally damage the fiber stretcher.
- **Maximum intermitted operating frequency at required voltage:** the maximum frequency that the amplifier can output at the required voltage.
- **Optical displacement at amplifier's maximum voltage:** the change in the optical path at the amplifier's full voltage range.

- **Cost:** cost of the amplifier(s) in USD. Note, two PX200s are required for the differential configuration.

4.2 Example:

Design an optical fiber stretcher with 1000um required displacement and 100 Hz bandwidth. The input to the online configuration tool is shown in Figure 7.

The image shows a digital interface for configuring design parameters. It features two main input fields, each with a slider below it. The first field is labeled 'Required Displacement (um)' and has the value '1000' entered. The second field is labeled 'Maximum Frequency at Required Displacement (Hz)' and has the value '100' entered. Below each field is a horizontal line with a red circular marker indicating the current slider position.

Figure 7: Design Configuration Tool Inputs

PX200 Differential Suitable		PX200 Differential Thermally limited		PX200 Single Not suitable	
Recommended number of turns	75	Recommended number of turns	80	Recommended number of turns	80
Resolution (assuming 16 bit input)	16.02 nm	Resolution (assuming 16 bit input)	17.09 nm	Resolution (assuming 16 bit input)	8.54 nm
Required voltage	382 Vpp	Required voltage	359 Vpp	Required voltage	200 Vpp
Optical displacement at required voltage	1.00 mm	Optical displacement at required voltage	1.01 mm	Optical displacement at required voltage	0.56 mm
Maximum continuous operating frequency at required voltage	1.46 kHz	Maximum continuous operating frequency at required voltage	1.65 kHz	Maximum continuous operating frequency at required voltage	5.31 kHz
Maximum intermittent operating frequency at required voltage	6.12 kHz	Maximum intermittent operating frequency at required voltage	6.52 kHz	Maximum intermittent operating frequency at required voltage	11.73 kHz
Optical displacement at amplifier's maximum Voltage	1.05 mm	Optical displacement at amplifier's maximum Voltage	1.12 mm	Optical displacement at amplifier's maximum Voltage	0.56 mm
Cost	\$5504	Cost	\$5504	Cost	\$2752

Figure 8: Design Configuration Tool Outputs.

5 Single Mode Fibers

The standard single-mode fibers are listed below. User supplied fibers are also possible.

Order Code	Specifications
SM300	0.13 NA; 320 - 430 nm; Cladding: 125 um
S405-XP	0.12 NA; 400 - 680 nm; Cladding: 125 um
SM450	0.12 NA; 488 - 633 nm; Cladding: 125 um
460HP	0.13 NA; 450 - 600 nm; Cladding: 125 um
SM600	0.13 NA; 633 - 780 nm; Cladding: 125 um
SM400	0.13 NA; 405 - 532 nm; Cladding: 125 um
630HP	0.13 NA; 600 - 770 nm; Cladding: 125 um
S630-HP	0.13 NA; 630 - 860 nm; Cladding: 125 um
780HP	0.13 NA; 780 - 970 nm; Cladding: 125 um
SM800-5.6-125	0.13 NA; 830 nm; Cladding: 125 um
SM800G80	0.16 NA; 830 nm; Cladding: 80 um
SM980-5.8-125	0.14 NA; 970 - 1650 nm; Cladding: 125 um
SM980G80	0.18 NA; 980 - 1650 nm; Cladding: 80 um
1060XP	0.14 NA; 980 - 1600 nm; Cladding: 125 um
980HP	0.2 NA; 980 - 1600 nm; Cladding: 125 um
1310BHP	0.13 NA; 1300 - 1625 nm; Cladding: 125 um
SM1250G80	0.12 NA; 1310 - 1550 nm; Cladding: 80 um
1550BHP	0.13 NA; 1460 - 1620 nm; Cladding: 125 um
SM1500G80	0.12 NA; 1550 nm; Cladding: 80 um
SM2000	0.11 NA; 1700 - 2100 nm; Cladding: 125 um
UHNA1	0.28 NA; 1100 - 1600 nm; Cladding: 125 um
UHNA3	0.35 NA; 960 - 1600 nm; Cladding: 125 um
UHNA4	0.35 NA; 1100 - 1600 nm; Cladding: 125 um
DCF13	0.12 NA; 1250 - 1600 nm; Cladding: 125 um
DCF4	0.11 NA; 1500 - 1625 nm; Cladding: 125 um
SM1550P	0.10 - 0.14 NA; 1310 - 1550 nm; Cladding: 125 um

6 Polarization Maintaining Fibers

Standard polarization maintaining fiber types are listed below. User supplied fibers are also possible.

Order Code	Specifications
PM-S350-HP	0.12 NA; 350 - 460 nm; Cladding: 125 um
PM-S405-XP	0.12 NA; 400 - 680 nm; Cladding: 125 um
PM460-HP	0.12 NA; 460 - 700 nm; Cladding: 125 um
460HP	0.13 NA; 450 - 600 nm; Cladding: 125 um
PM630-HP	0.11 NA; 620 - 850 nm; Cladding: 125 um
PM780-HP	0.12 NA; 770 - 1100 nm; Cladding: 125 um
PM980-XP	0.12 NA; 970 - 1550 nm; Cladding: 125 um
PM1300-XP	0.12 NA; 1270 - 1625 nm; Cladding: 125 um
PM1550-XP	0.13 NA; 1440 - 1625 nm; Cladding: 125 um
PM2000	0.2 NA; 1850 - 2200 nm; Cladding: 125 um
PS-PM980	0.12 NA; 980 nm; Cladding: 125 um
HB830Z	0.14 NA; 780 - 850 nm; Cladding: 80 um
HB1060Z	0.14 NA; 1014 - 1114 nm; Cladding: 125 um
HB1550Z	0.09 - 0.11 NA; 1500 nm; Cladding: 125 um
HB800G	0.16 NA; 830 nm; Cladding: 80 um
HB980T	0.14 NA; 980 nm; Cladding: 125 um
HB1250T	0.12 NA; 1310 nm; Cladding: 125 um
HB1500T	0.12 NA; 1550 nm; Cladding: 125 um

7 Optical Connectors For OEM

Order Code	Description
FC/PC	FC/PC
FC/APC	FC/APC
LC/PC	LC/PC
SC/PC	SC/PC
ST	ST
SMA	SMA
LC/SSF	1.25 mm (LC) Stainless Steel Ferrule
LC/CF	1.25 mm (LC) Ceramic Ferrule
FC/SSF	2.5 mm (FC) Stainless Steel Ferrule
FC/CF	2.5 mm (FC) Ceramic Ferrule
SMA/N	SMA with Hex Nut

8 Electrical Configuration

The PiezoDrive FS is available in single-ended and differential drive configuration, which are illustrated in Figure 9. The simplest configuration is the single-ended option where the external electrode is grounded and the high-voltage signal is applied to the internal electrode. The differential option is an alternative which doubles the voltage across the piezoelectric tube but requires two connectors and amplifier channels, one of which must be inverting.

The enclosed version of the FS fiber stretcher can be ordered with either BNC or SHV connectors, which is primarily determined by safety considerations. BNC connectors are convenient since many lab instruments use this type. However, the centre conductor can potentially be touched when the connectors are not mated. For this reason, BNC connectors are recommended for operation below ± 250 V, which suits many applications and recommended drivers. BNC connectors are typically rated for operation up to ± 1000 V, but this should only be used if there is zero risk of disconnection while the driver is energized.

The preferred choice of connector for voltages greater than ± 250 V, is an SHV connector. These are less common than BNC connectors and have a shrouded conductor which significantly reduces the risk of electrocution while the cable is disconnected. SHV connectors and cables support the full -500V to +2000 V maximum voltage range of the fiber stretcher.

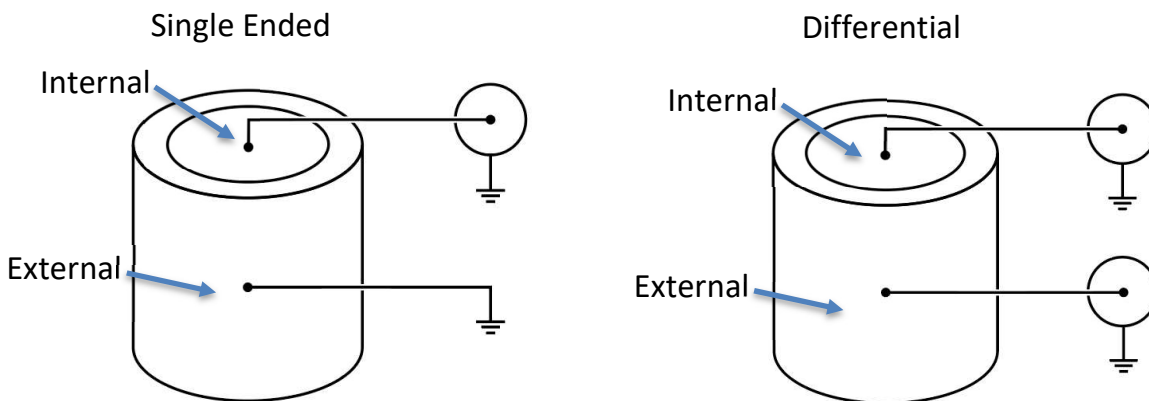

Figure 9. Single-ended and differential electrical configuration.

9 Recommend Drivers

PiezoDrive offers a range of suitable drivers, which are listed in the table below. When the differential configuration is used with a single-channel driver e.g. PX200, two driver units are required, one of which must be configured as inverting.

The main considerations when choosing a driver are the voltage range, output current, and number of channels. The output current determines the maximum operating frequency at full voltage. The simplest method for selection is to use the [online configuration tool](#) or use the table below.

Amplifier	Electrical Config.	Voltage Range	Max Frequency at Full Voltage	Number of FS Stretchers per Amplifier	Amplifier Order Code
TD250	Single	± 250	85 Hz	6	TD250-SGL
TD250	Differential	± 500	40 Hz	3	TD250-INV
PD200	Single	± 100	4300 Hz	1	PD200-V100,100
PD200X4	Single	± 100	4300 Hz	4	PD200X4-V100,100
PD200X4	Differential	± 200	2100 Hz	2	PD200X4-V100,100
PX200	Single	± 100	11000 Hz	1	PX200-V100,100
PX200	Differential	± 200	5800 Hz	0.5	PX200-V100,100

Table 1. Recommended amplifiers and operating ranges. All use BNC connectors.

10 Example Electrical Connections

The following examples illustrate how to connect the FS fiber stretcher to a driver.

10.1 PX200 Differential Drive Configuration

The differential configuration requires two amplifier channels. Since the PX200 is a single channel device, two units are required. In the example below, two PX200-V100,100 drivers are used, which have a an output range of ± 100 V per channel and a gain of 20. Since the gain is doubled by the differential configuration, a ± 5 V input signal will result in a ± 200 Volts across the tube.

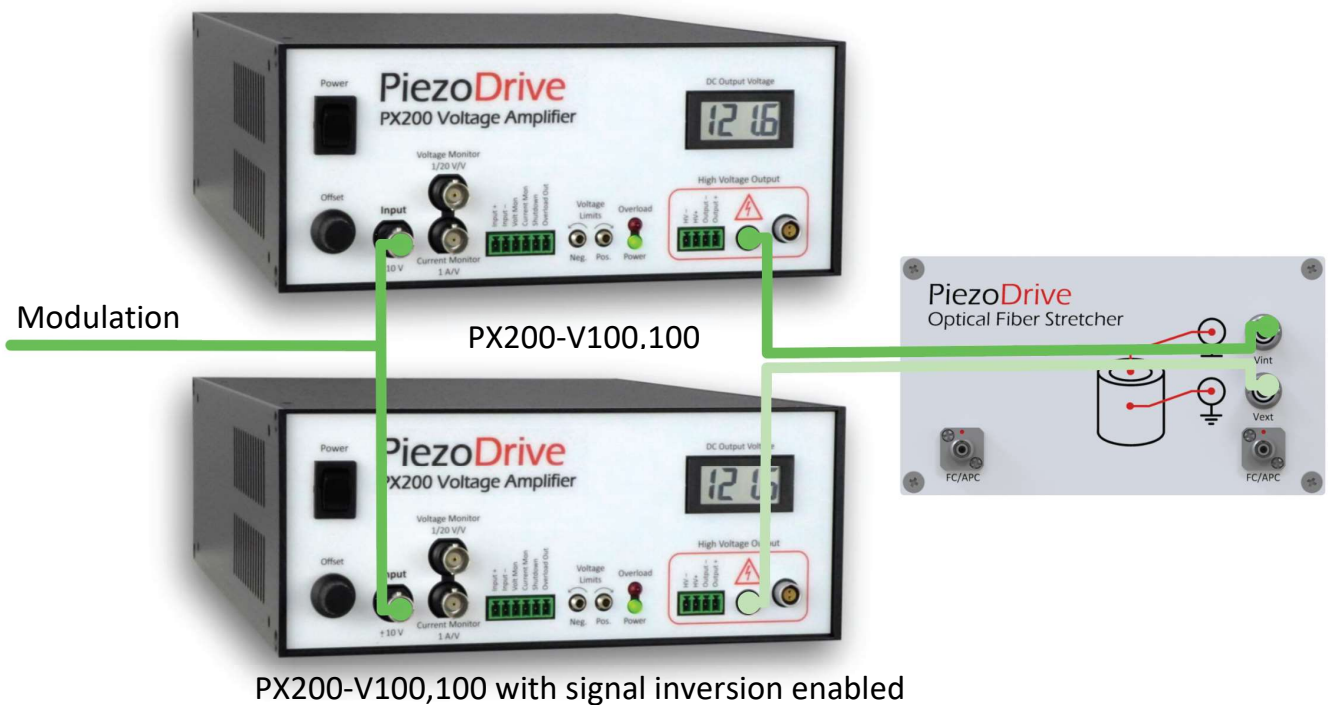
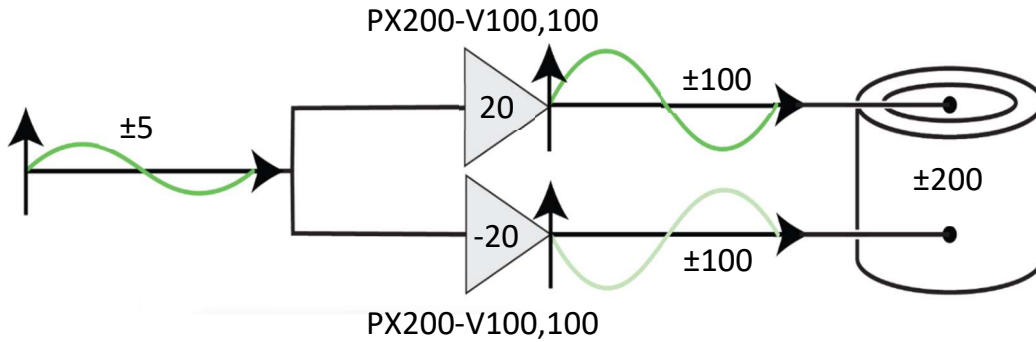

Figure 10. Example: Fiber stretcher driven by two PX200 in differential configuration.

10.2 TD250 Differential Drive Configuration

In the example below, a TD250-INV driver is used, which has an output range of ± 250 V per channel and a gain of 25. Since the gain is doubled by the differential configuration, a ± 10 V input signal will result in a ± 500 Volts across the tube

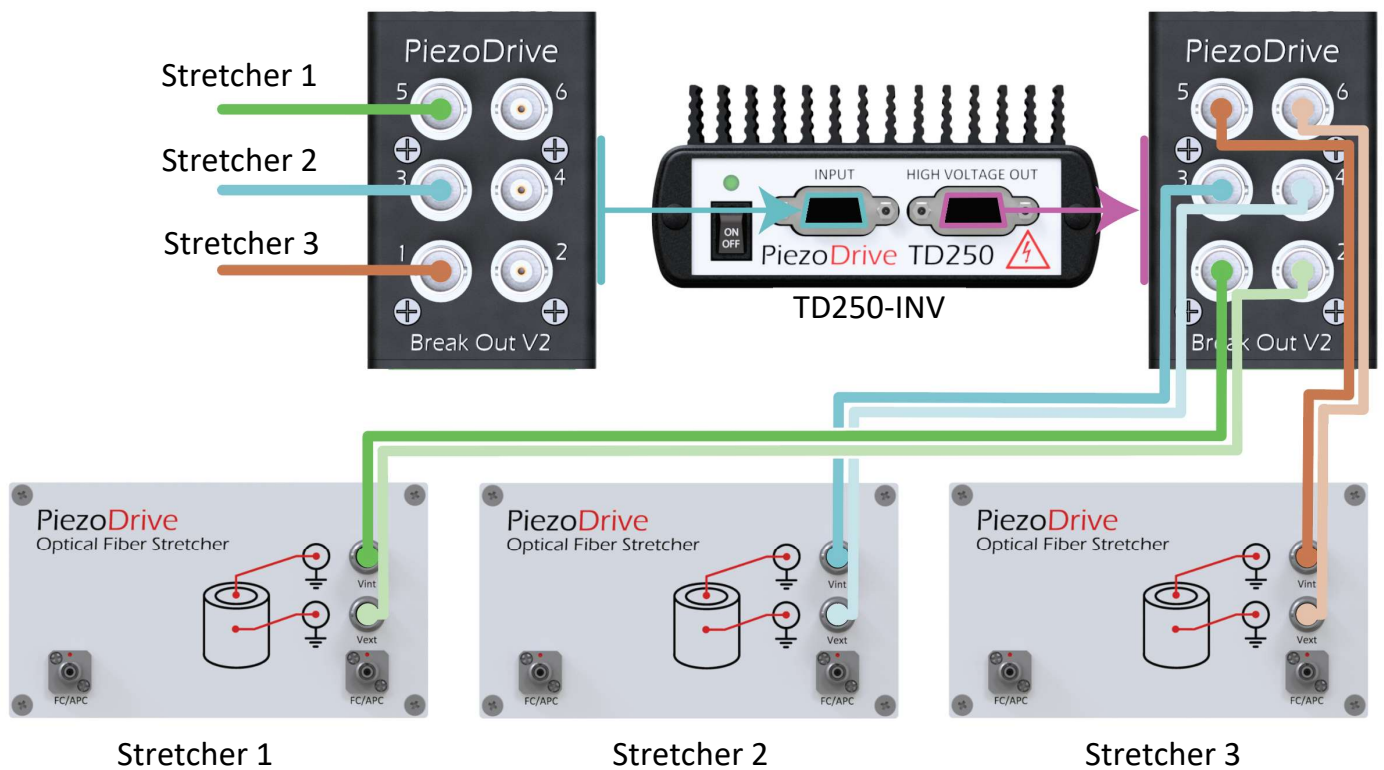
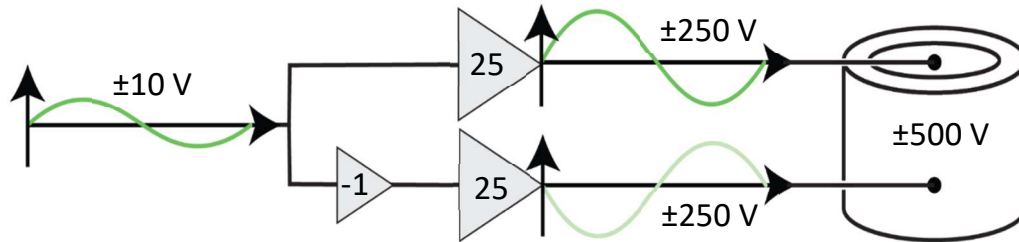

Figure 11. . Example: Three fiber stretchers driven by one TD250 in differential configuration.

10.3 PD200X4 Differential Drive Configuration

In the example below, a PD200X4-V100,100 driver is used, which has an output range of ± 100 V per channel and a gain of 20. Since the gain is doubled by the differential configuration, a ± 5 V input signal will result in a ± 200 Volts across the tube

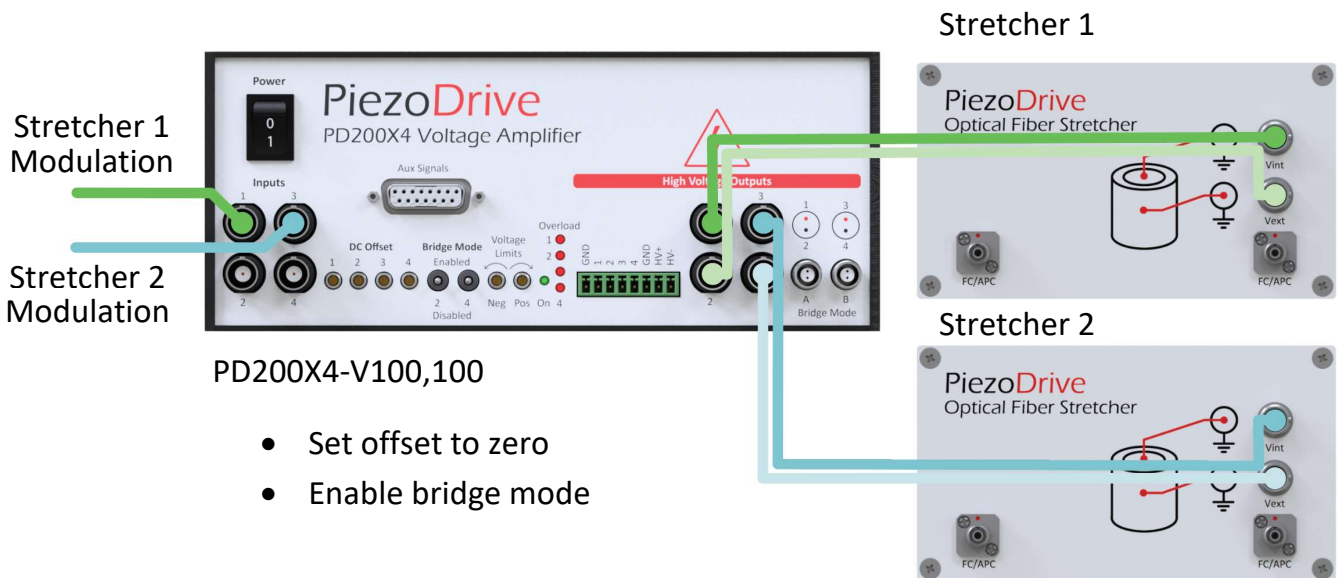
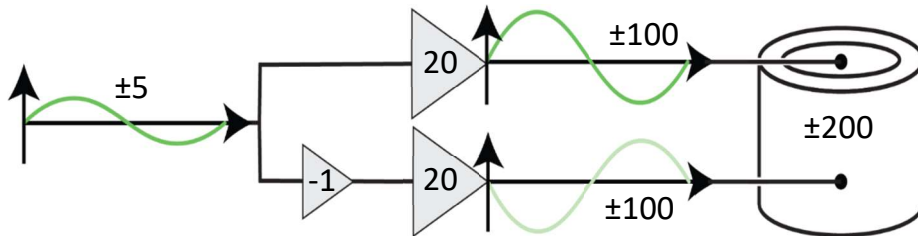
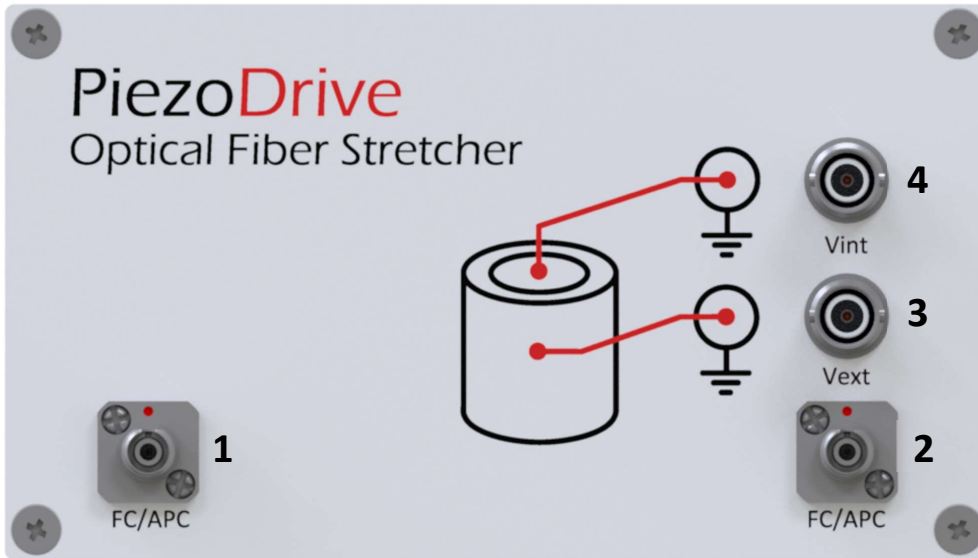

Figure 12. Example: Two fiber stretchers driven by one PD200X4 in differential configuration.

11 Enclosure Front Panel

11.1 Differential Electrical Configuration



1. Optical connector 1 (FC/APC)
2. Optical connector 2 (FC/APC)
3. External electrode connector (BNC or SHV)
4. Internal electrode connector (BNC or SHV)

11.2 Single-Ended Electrical Configuration

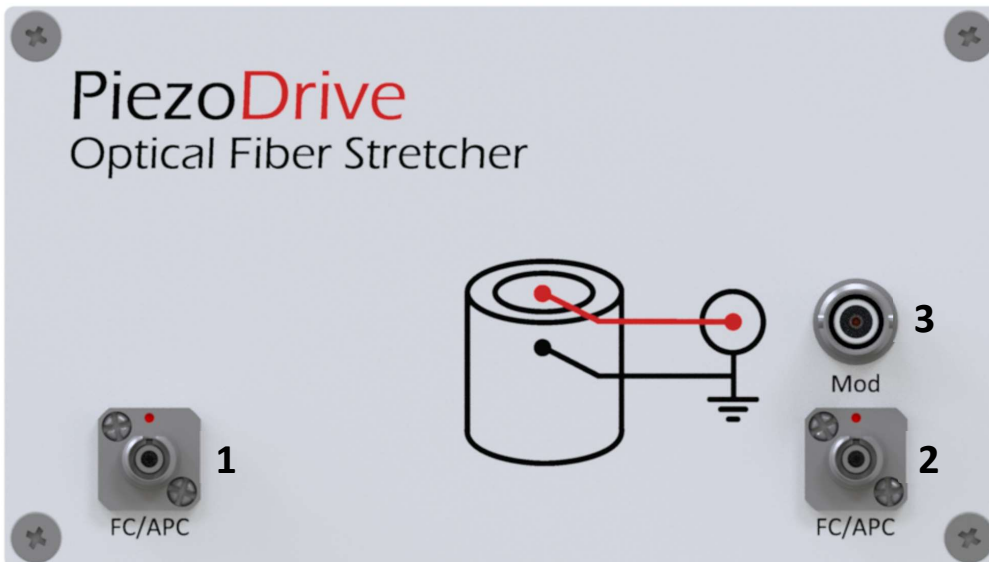

1. Optical connector 1 (FC/APC)
2. Optical connector 2 (FC/APC)
3. Electrical connector (BNC or SHV)

12 Ordering

The PiezoDrive FS can be ordered online or by requesting a quote from info@piezodrive.com. When requesting a quote, it is preferable to state an exact order code in the format listed below.

FS-(Fiber Type)-(Fiber Order Code)-N(Number of Turns)-(Enclosure)-(Optical Connector 1)-(Optical Connector 2)-(Electrical Configuration)

The options are:

- Fiber Type
 - SM = Single mode
 - PM = Polarization maintaining
- Fiber Order Code: refer to Sections 5 and 6
- Number of Turns: refer to Section **Error! Reference source not found.**
- Enclosure
 - OEM = OEM version without enclosure
 - ENCL = With enclosure
- Optical Connector 1
 - Not required for enclosed version
 - For the OEM version, refer to Section 7
- Optical Connector 2
 - Not required for enclosed version
 - For the OEM version, refer to Section 7
- Electrical Configuration: refer to Section 8
 - Not required OEM version
 - BNCSGL = Single BNC connector
 - BNCDIF = Two BNC connectors
 - SHVSG L = Single SHV connector
 - SHVDIF = Two SHV connectors

Example 1: OEM version with 35 turns of SM300 single-mode optical fiber using FC/APC connectors:

FS-SM-SM300-N35-FC/APC-FC/APC

Example 2: Enclosed version with a single BNC connector and 70 turns of 460HP polarization-maintaining fiber:

FS-PM-460HP-N70-ENCL-BNCSGL

13 Specifications

Specification	Value	Notes
Maximum input voltage V	-500 V to +2000 V	Dependent on connector type and configuration
Tube impedance	280 nF	
Electrical connections	BNC or SHV	
Electrical configurations	Differential or single-ended	
Wavelength range	320 nm to 2100 nm	Dependent on fiber choice
Optical path displacement sensitivity	36 nm/ N/V	Dependent on the number of fiber turns
Number of turns N	1,5,10,15 ... 80	
Total fiber length	188 mm/ N	Dependent on the number of fiber turns
Resonance frequency	14.5 kHz	
Fiber type	SM, PM	
Optical Connectors	FC/APC	
Optical Connectors (OEM)	Custom	
Package dimensions	171 x 153 X 90 mm	Length x width x height
Package dimensions (OEM)	90 x 90 x 52 mm	Length x width x height

14 Safety Warnings

14.1 High Voltage

This product requires the use of potentially lethal voltages.

Observe Low-Voltage (as per ANSI C84.1-1989) safety precautions, e.g.

- Use an observer trained in low-voltage rescue
- Do not operate with exposed conductors
- Use appropriate signage.

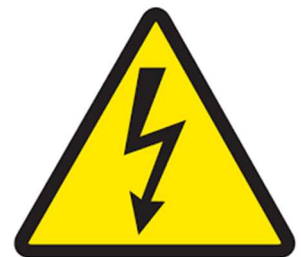

15 Dimensions

15.1 Enclosure Version

A 3D Model can be downloaded from <https://www.piezodrive.com/wp-content/uploads/steps/FS-ENCL.stp>

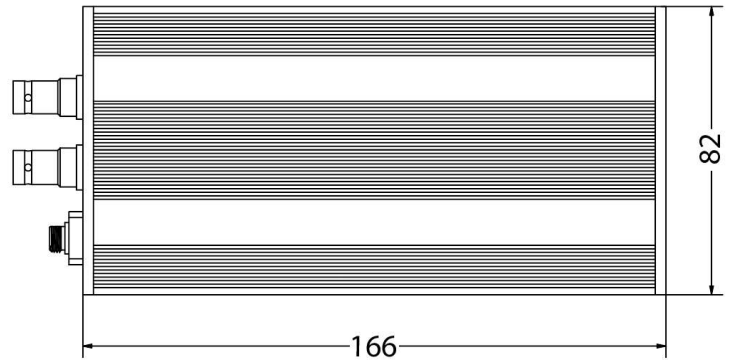
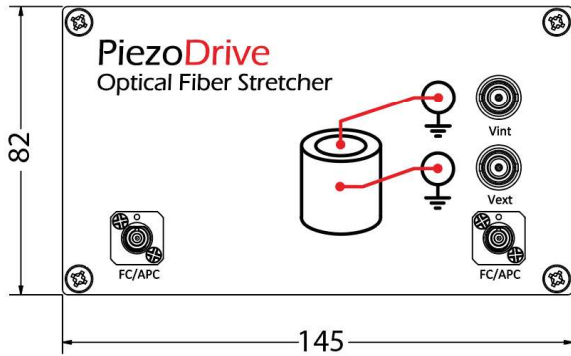
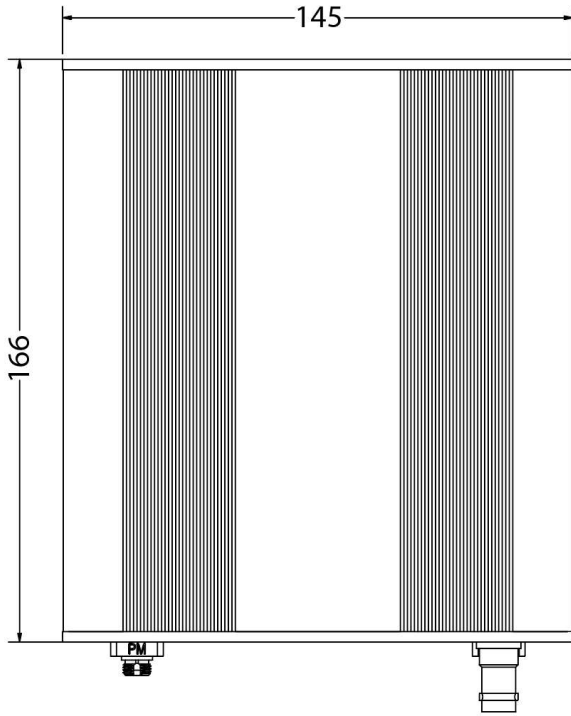

15.2 OEM Version

A 3D Model can be downloaded from <https://www.piezodrive.com/wp-content/uploads/steps/FS-OEM.stp>

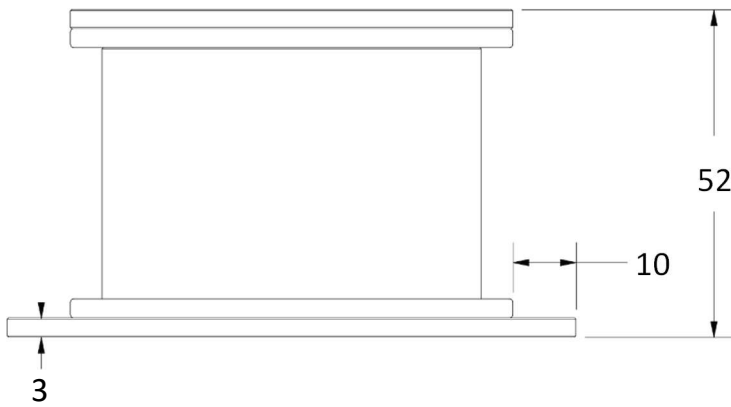
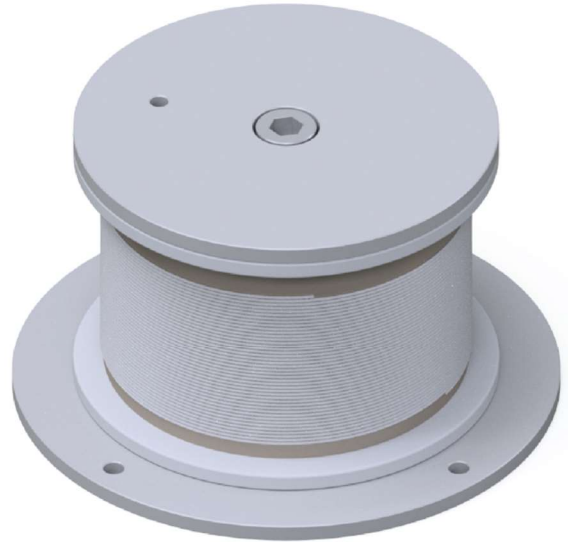
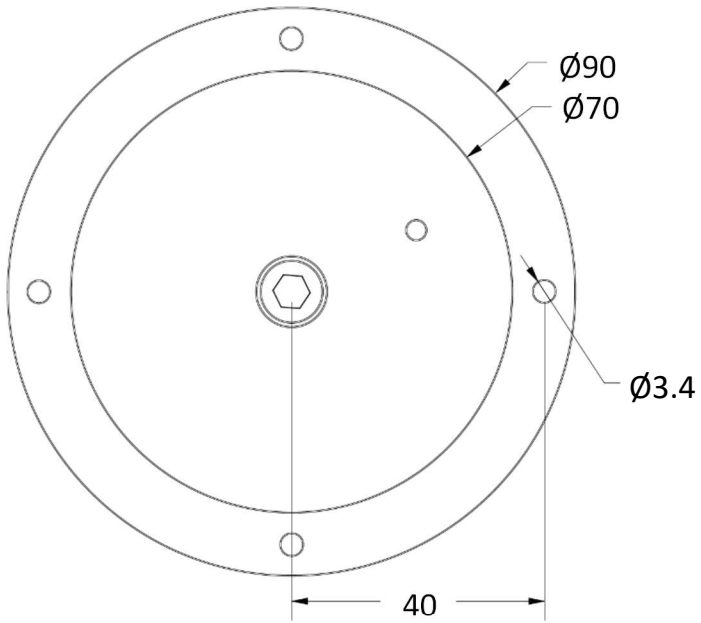

16 Delivery Contents

- FS Fiber Stretcher (in chosen configuration)

17 Warranty

The FS fiber stretcher is guaranteed for a period of 12 months against manufacturing defects. The warranty does not cover damage caused by exceeding the operating limits, for example:

- Overheating caused by applying continuous voltages above the recommended amplitude
- Mechanical failure caused by operating near a resonance frequency